



**Thank You for purchasing this**

**Factory Service Manual on EBAY**

**from PCTECHINFO!**



**[Click Here](#) for more Factory Service**

**Manuals for other Computer and**

**Printer / Copier Manufacturers**

**from PCTECHINFO!**



---

Front Cover

# Service Guide

OKICOLOR 8 & OKICOLOR 8n  
Digital LED Page Printers

Adobe Acrobat printable reference copy  
of the OKIDATA Service Training Manual.  
12/20/99

Note: This Adobe Acrobat version of the Okidata Service Training Manual was built with the pictures rendered at 72 dpi, which is ideal for screen viewing. For future updates to this manual, and more on-line information visit our **Business Partner Exchange (BPX) at <http://bpx.okidata.com>**.

---

Copyright 1999, Okidata, Division of OKI America, Inc. All rights reserved.

---

**Service Guide - OKICOLOR8****0 Introduction**

....Preface	2
-------------	---

**1 Specifications**

1.1 Basic System Configuration	3
1.2 Printer Specifications	4
1.3 Option Specifications	5
1.4 Basic Specifications	6

**2 Operation**

2. Operation	7
2.1 Main Control Board (PCE PCB)	8
2.2 Engine Control Board (PX4 PCB)	9
2.3 Power/Board	10
2.4 Mechanical Processes	11
....2.4.1 Electrophotographic processing mechanism	12
....2.4.2 Paper running process	13
2.5 Sensors	14
....2.5.1 Paper Related Sensors	15
....2.5.2 Other sensors	16
2.6 Correction of Color Deviation	17
2.7 Transfer Control according to Environmental Changes	18
2.8 Form Jam Detection	19
2.9 Cover Opening	20
2.10 Toner Lower Detection	21
2.11 Page Size Detection	22
2.12 Power-on Processing	23

**3 Disassembly**

3.0 Parts Replacement	24
3.1 Precautions for Parts Replacement	25
3.2 Parts Layout	26
3.3 How to Change Parts	27
....3.3.1 Cover Assy Rear	28
....3.3.2 Motor-Fan (80-25)	29
....3.3.3 Paper Eject Assy	30
....3.3.4 Cover Assy Stacker, Guide Eject FD Assy	31
....3.3.5 Upper Frame Assy	32
....3.3.6 Plate Support Assemblies	33
....3.3.7 Limiter 2way (L), (R) / Plate Guide (L), (R)	34
....3.3.8 Cover	35
....3.3.9 PCE PCB Assy	36
....3.3.10 Motor Fan (CU)	37
....3.3.11 PXF PCB / PX4 PCB	38
....3.3.12 Gear Heat Assy	39
....3.3.13 Main Motor (A), (B) Assy	40
....3.3.14 Gear One-way (Z30)	41
....3.3.15 Motor Assy Belt	42
....3.3.16 Power Supply Unit, Holder Inlet, Sheet Insulation	43
....3.3.17 Sensor Assy Box Toner	44
....3.3.18 Square-shaped Connector	45
....3.3.19 Motor - Pulse (ID)	46
....3.3.20 One-way Gears	47

## Table of Contents

## Page

---

....3.3.21 Feeder Unit Front	48
....3.3.22 Manual Feed Hopper Assy	49
....3.3.23 Guide Paper Input Assy	50
....3.3.24 Two Lever Input Sensors, Lever 2nd Feed Sensor	51
....3.3.25 Roller Registration, Roller Assy Hopping	52
....3.3.26 Hopping Roller Assy	53
....3.3.27 PXU PCB/PXM PCB, Lever Resist Sensor	54
....3.3.28 Paper End Lever	55
....3.3.29 PCO PCB (Operator Panel)	56
....3.3.30 Holder Gear Toner Assy	57
....3.3.31 Plate Latch Lever (FD), Spring Latch Lever (FD)	58
....3.3.32 Transfer Belt	59
....3.3.33 High Voltage Power Supply Unit, Bracket HV (BT) Assy	60
....3.3.34 Eraser Bracket Assy, Eraser Bracket (KCM) Assy	61
....3.3.35 Shaft Link	62
....3.3.36 Contact Bracket (BL-R) Assy, Contact Bracket (CL-R) Assy	63
....3.3.37 Contact (BL-L) Assy, Contact (CL-L) Assy	64
....3.3.38 Contact SB Assy	65
....3.3.39 PXC PCB	66
....3.3.40 Heat Unit Assy (Fuser unit and oil roller)	67
....3.3.41 Oil Roller Kit	68
....3.3.42 Lever Lock Heat (L)/(R), Guide Side Heat, Spring Lock	69
....3.3.43 PXL PCB	70
....3.3.44 Heat Unit Guide Assy	71
....3.3.45 Holder LED Assy, LED Head	72
<b>4 Adjustments</b>	
4. Adjustments	73
4.1 Maintenance Modes and Their Functions	74
....4.1.1 User maintenance mode	75
....4.1.2 System maintenance mode	76
....4.1.3 Engine maintenance mode	77
4.2 Adjustments after Parts Replacement	78
....4.2.1 Confirm the LED head driving time	79
....4.2.2 Color Registration Using the Operator Panel (Color deviation correction)	80
<b>5 Maintenance</b>	
Periodic Maintenance	81
....5.1 Periodically Replaced Parts	82
....5.2 Cleaning	83
....5.3 Cleaning the LED Lens Array	84
....5.4 Cleaning the Pickup Roller	84
<b>6 Troubleshooting Procedures</b>	
6.0 Troubleshooting Procedures	85
....6.1 Troubleshooting Tips	86
....6.2 Points to Check before Correcting Image Problems	87
....6.3 Tips for Correcting Image Problems	87
....6.4 Preparation for Troubleshooting	88
....6.5 Troubleshooting Flow	89

## Table of Contents

## Page

---

.....6.5.1 LCD status message/trouble list	90
.....6.5.2 LCD message troubleshooting	91
.....(1) The printer does not work normally after turned on.	91
.....(2) JAM ERROR	91
.....(3) Paper Size Error	91
.....(4) Image Drum Unit (IDU) Up/Down Error	91
.....(5) Fusing Unit Error	91
.....(6) Fan Motor Error	91
.....(7) Cannot Receive Data from Parallel Interface	91
.....6.5.3 Image Troubleshooting	92
.....(1) Light or blurred images on the whole printout area	92
.....(2) Dark background	92
.....Printout colors different from original colors	
.....(3) Blank paper	93
.....(4) Vertical black (black stripe or lines in the vertical direction)	94
.....(5) Vertical white (White stripe or lines in the vertical direction)	95
.....(6) Poor fusing (Images are blurred or peeled off when touched)	96
.....(7) Evenly spaced, repeating marks (Cyclical printout defects)	97
.....(8) Missing characters or colors	98
.....(9) Poor synthesization Color	99
.....(10) Printout colors diferent from original colors	99
<b>7 Wiring Diagram</b>	
7.1 Resistance Check	100
7.2 Program/Font ROM Location	101
<b>8 Illustrated Parts List</b>	
Figure 8-1: Covers (Top & Sides)	102
Figure 8-2: Printer Unit	102
Figure 8-3: Main Chassis Unit (1)	102
Figure 8-4: Main Chassis Unit (2)	102
Figure 8-5: Main Chassis Motor/PCB	102
Figure 8-6: Frame Upper Assy	102
Figure 8-7: Guide Cassette (R) Assy	102
Figure 8-8: Main Motor (A) Assy	102
Figure 8-9: Main Motor (B) Assy	102
<b>A Centronics Parallel Interface</b>	
Centronics Parallel Interface	102



---

**Preface**

This manual provides procedures and techniques for the troubleshooting, maintenance, and repair of OKICOLOR8.

This manual is written for maintenance personnel, but it should always be accompanied with the OKICOLOR8 User's Manual for procedures for handling and operating OKICOLOR8. For repairing each component of OKICOLOR8, see the Troubleshooting Manual.

**[Notices]**

The contents of this manual are subject to change without prior notice. Although reasonable efforts have been taken in the preparation of this manual to assure its accuracy, this manual may still contain some errors and omissions. OKI will not be liable for any damage caused or alleged to be caused, by the customer or any other person using this maintenance manual to repair, modify, or alter OKICOLOR8 in any manner.

**[Warning]**

Many parts of OKICOLOR8 are very sensitive and can be easily damaged by improper servicing. We strongly suggest that OKICOLOR8 be serviced by OKI's authorized technical service engineers.



**1.1 Basic System Configuration**

This diagram shows the basic system configuration of OKICOLOR 8 is illustrated in Figure 1.1 below.

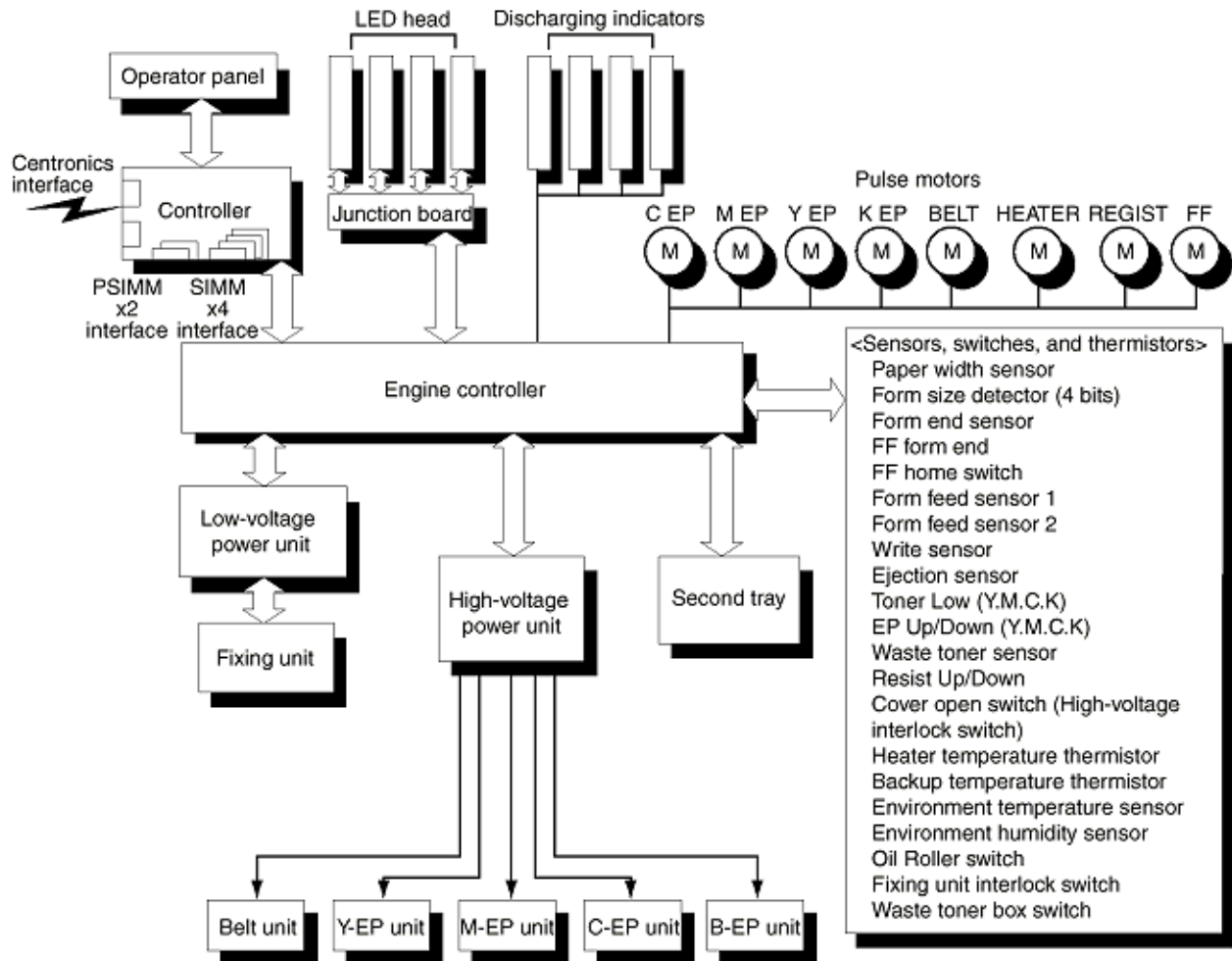
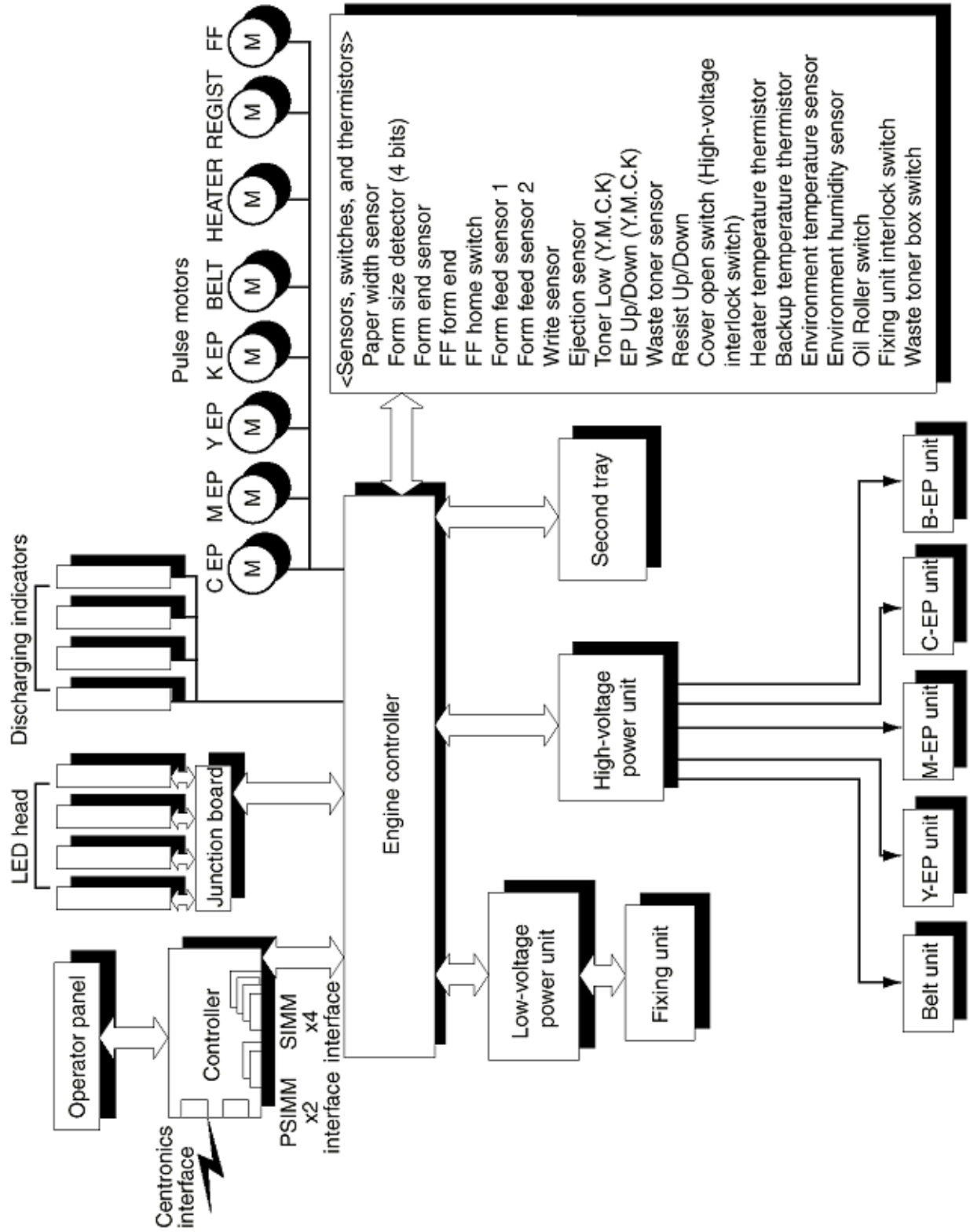


Figure 1.1

< same diagram -- different view >









## 1.2 Printer Specifications

This printer unit is composed of the following hardware.

- Electro-photographic processor
- Paper feeder
- Controller (CU part / PU Part)
- Operator panel
- Power board (High voltage part / PU part)

This diagrams shows the printer unit configuration.

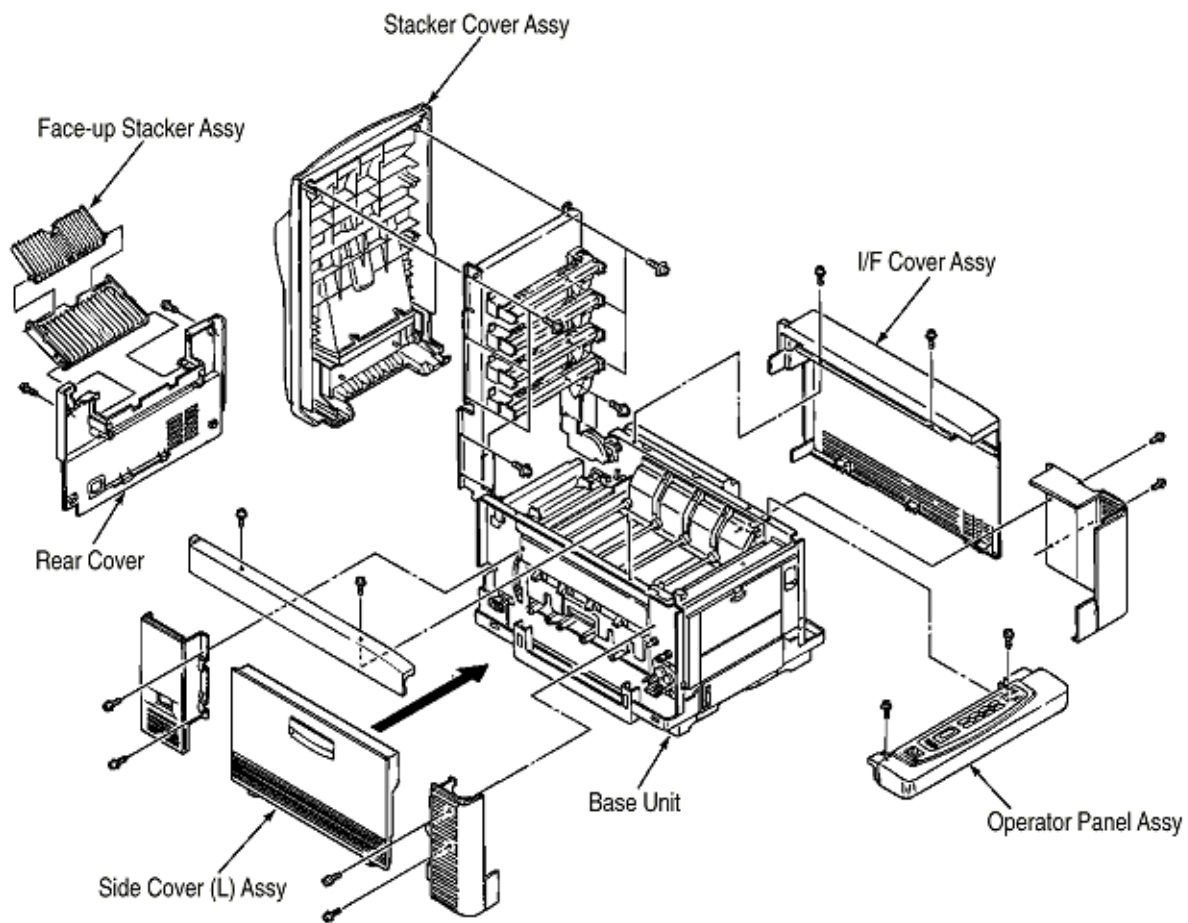


Figure 1.2

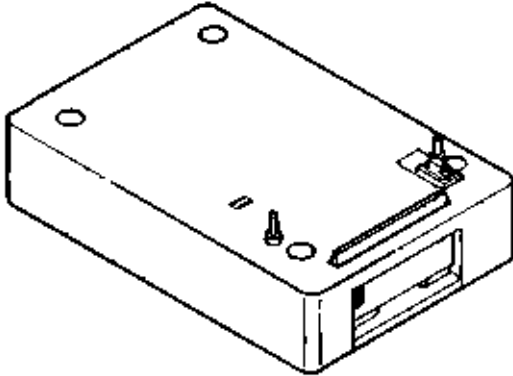


---

### 1.3 Option Specifications

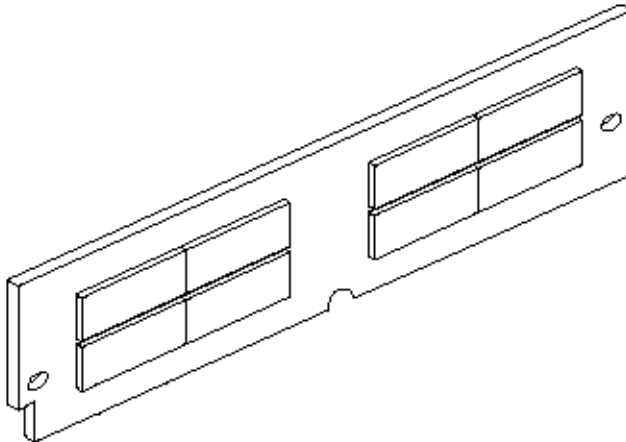
The OKICOLOR8 options are listed below.

(1) Second Paper Feeder



(2) RAM SIMM module (72 pin SIMM, 4MB/8MB/16MB/32MB)

- Make sure to use a set of 2 of the same volume size modules.





**1.4 Basic Specifications**

- (1) **Dimensions**                    Width: 18.8" Length: 24.5" Height: 15.6"
- (2) **Weight**                         Approx. 106 lbs. without box
- (3) **Form**
  - Type:** Ordinary paper (Hammermill xx lb.) and Transparency (Only 3M CG3710)  
Recommended paper (for color printing)  
Color laser paper (20 lb to 24 lbs.)  
Note: the printout color tones are dependent upon the whiteness of the print paper.
  - Sizes:** Letter, Legal (13" or 14"), Executive, A4, A5, B5, and B6 (1st tray and front feeder)
  - Reams:** 1st tray - 20 lbs. to 28 lbs.  
2nd tray - 20 lbs. to 28 lbs.  
Front feeder - 20 lbs. to 53 lbs. (110 lbs. index)
- (4) **Printing speed:**                8 pages per minute (5 pages per minute: Card Stock, Labels & OHP / 34 lbs. ~ 44 lbs.)
- (5) **Resolution**                    600 dots per inch x 600 dots per inch
- (6) **Input voltage**                    120VAC +5.5%, -15%  
230VAC +10%
- (7) **Power consumption**            Peak: Typical operation  
Idle: Power save mode
- (8) **Frequency**                      50Hz or 60Hz +2%, -2%
- (9) **Noises**                            Operating: 54 decibels (without 2nd tray), 55 decibels (with 2nd tray)  
Standby: 45 decibels  
Power-saving: 43 decibels
- (10) **Expendables and service life**
  - Toner Cartridge: Approx. 3000 pages (5% density) (each of C, M, Y, and K)
  - Image Drum: Up to 13,000 pages (5% density, continuous) (each of C, M, Y and K)
  - Waste Toner Box: Up to 25,000 sheets (under typical printout conditions: Single images of 5% density, equivalent to printout using 14 toner cartridges)
  - Oil Roller Unit: Up to 10,000 sheets (Life defined in the number of actual printed paper sheets)
  - Note:** Y=Yellow, M=Magenta, C=Cyan, K=Black
- (11) **Periodically replaced parts**
  - Fuser Heat Unit Assy: 60,000 pages
  - Transfer Belt Cassette Assy: 50,000 pages

**(12) Temperatures and relative humidities**

**Temperature**

Temperature conditions			
	Fahrenheit	Celsius	Remarks
Operating	60.8 to 89.6	16 to 32	17 Celsius to 27 Celsius (for assurance of full-color printout quality)
Non-operating	50 to 109.4	10 to 43	Power off
Storage (1 year max.)	-33 to 109.4	-6 to 43	with drum and toner
Delivery (1 month max.)	-20 to 122	-29 to 50	without drum and toner and Belt Cassette Assy
Delivery (1 month max.)	-20 to 122	-29 to 50	with drum and toner

**Humidity**

Humidity condition			
	Fahrenheit	Celsius	Remarks
Operating	20 to 80	25	50% to 70% (for assurance of full-color printout quality)
Non-operating	10 to 90	26.8	Power off
Storage	10 to 90	35	
Delivery	10 to 90	40	

**(13) Printer life** - 300,000 (A4) pages or 5 years

---

Copyright 1999, Okidata, Division of OKI America, Inc. All rights reserved.



**2. Operation**

OKICOLOR8 is a tandem color electrophotographic page printer, using 4992 Pixel-LED technologies, OPC, dry single-component non-magnetic developing, roller transfer, heat-compression fixing (fusing). The printing method used is a Black Writing method which applies light beams to printout areas.

Here is the Functional Block Diagram of OKICOLOR8.

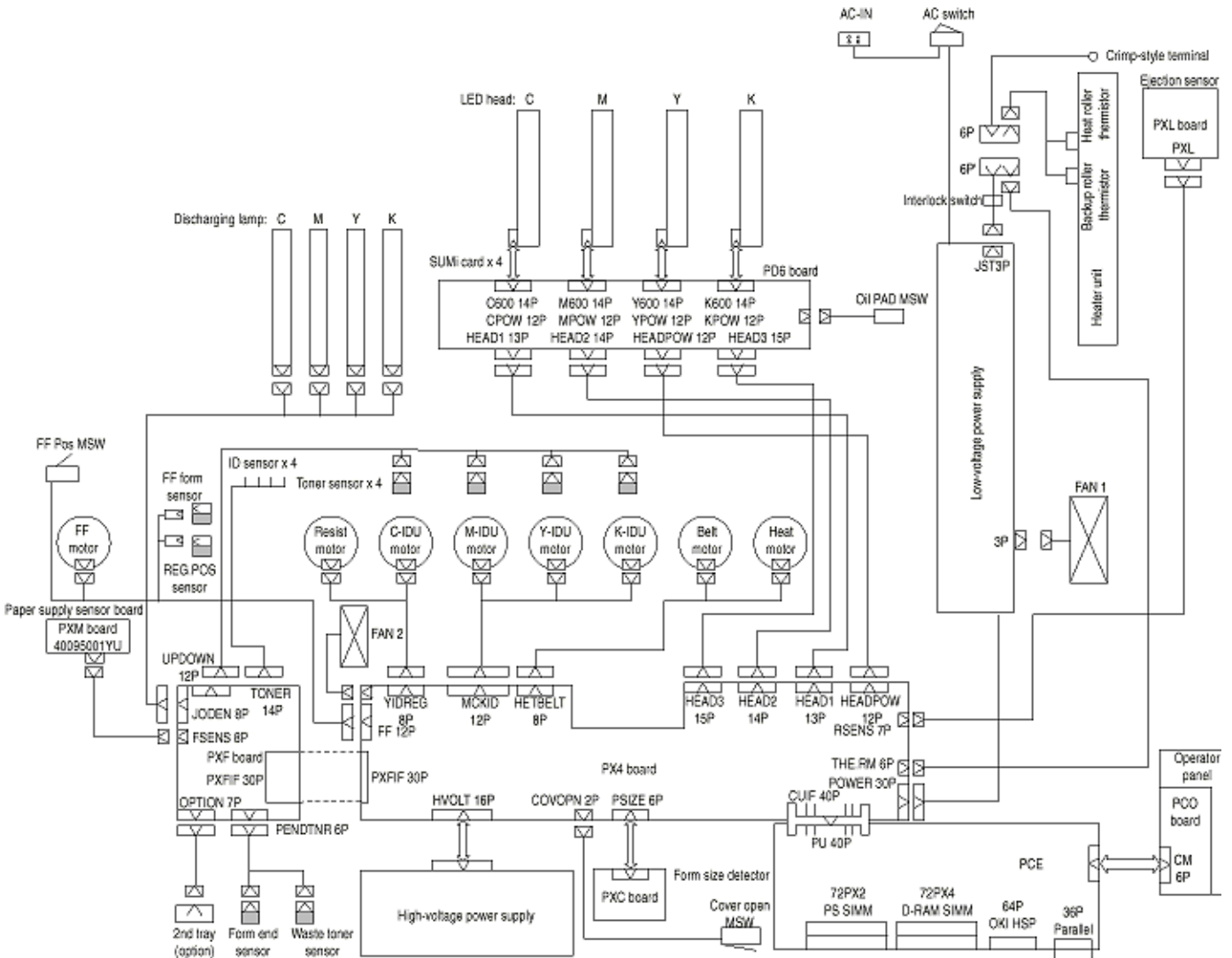
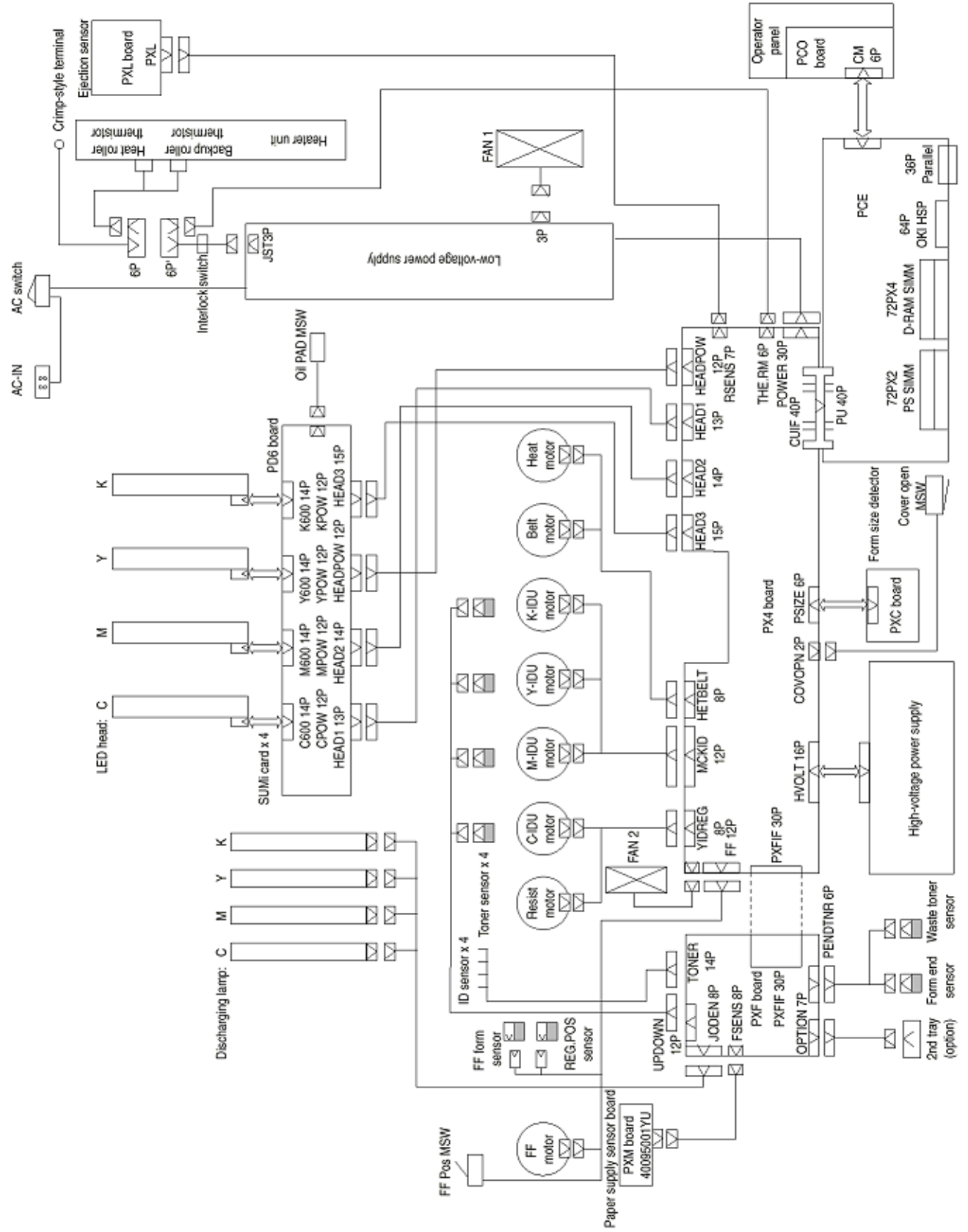


Figure 2.1

< same diagram - side view >



---

Copyright 1999, Okidata, Division of OKI America, Inc. All rights reserved.



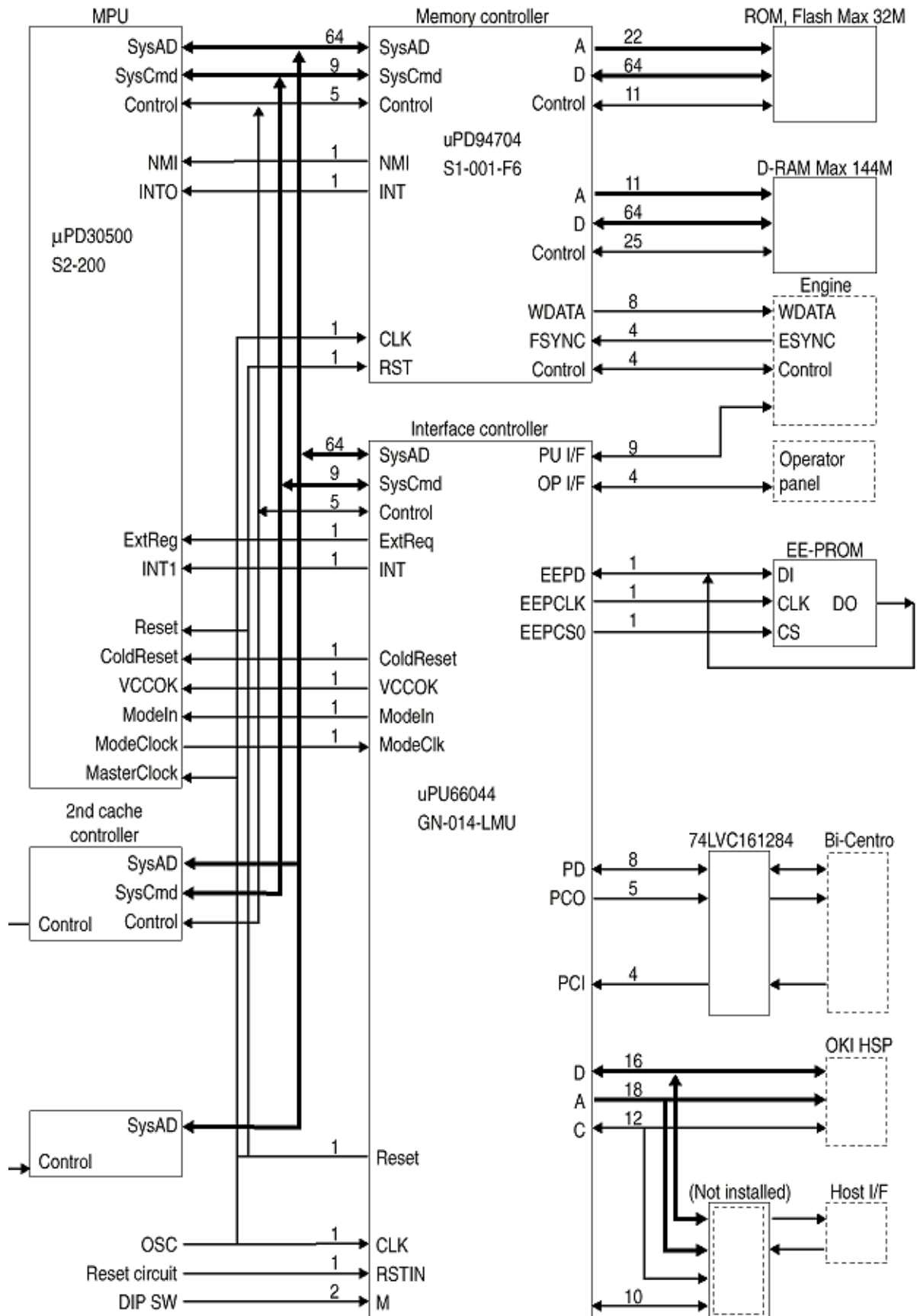


---

## **2.1 Main Control Board (PCE PCB)**

The control board consists of a CPU block, a memory control LSI block, an interface control LSI block, a DRAM block, an EEPROM block, a mask ROM block, and an interface block.

Here is the Functional Block Diagram of the main control board (PCE PCB).



(TE6135 (6137), 16550, 53C80)

## Functional Block Diagram of Main Control Board

- (1) **CPU**  
The CPU is a 64-bit RISC architecture processor (provided by NEC). It inputs a frequency of 50 MHz and runs at 200 MHz. It transfers data to a from memory at 50 MHz.
- (2) **Mask ROM**  
The mask ROM block consists of four 16 Mbit (1M x 16 bits) chips and its total size is 8M bytes. The chips are mounted on the PCE-PCB by means of IC sockets and store programs and character fonts.
- (3) **DRAM**  
The DRAM block consists of eight 16 Mbit (1M x 16bits) chips and its total size is 16M bytes. The chips are mounted on the PCE-PCB and can be expanded up to 144M bytes by adding the 32M byte SIMMs to the SIMM slots on the PCE-PCB.
- (4) **EEPROM**  
The EEPROM block consists of 16K-bit chips mounted on a board by means of IC sockets and stores the following:
  - Menu data
  - Counter values
  - Adjustment values
- (5) **Flash ROM**  
The Flash ROM block consists of four 4M bit (256K x 16bits) chips and its total size is 2M bytes. The chips are mounted on the PCE-PCB and are used for storing fonts, macro and demo pages.
- (6) **Memory control LSI**  
This block mainly consists of memory control, CPU control, compression and decompression, and video interface functions.
- (7) **Interface control LSI**  
This block mainly consists of PU interface control, operator panel interface control, EEPROM control, parallel interface control, and HSP control functions.

(8) **Host interface**

The printer has the following interfaces to the host.

- Centronics bi-directional parallel interface
- Network interface (Option)

The single effective interface or the automatic interface select mode can be selected using the menu. If the busy state of the printer continues for a long time period, the buffer near-full control releases the busy status at constant intervals even if the host side is busy so as not to cause interface time-out at the host side.

(a) Centronics bi-directional parallel interface

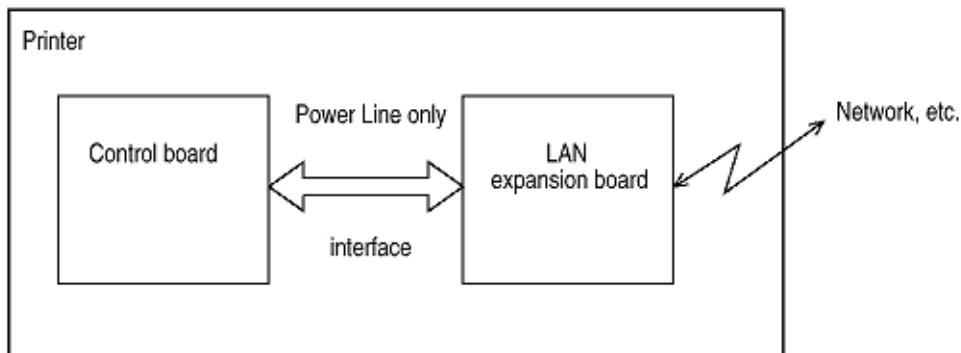
This is an interface conforming to IEEE-1284 and provides either unidirectional and bi-directional communications according to each of the following communication modes.

- **Compatibility mode** - Unidirectional communications from the host to the printer.
- **Nibble mode** - This mode transfers 4-bit wide data from the printer to the host. In this mode, each bit of 1-byte data transmits in the form of two nibbles using ERROR, BUSY, FAULT, and SELECT signal leads. This mode can provide bi-directional operation in combination with the compatibility mode.
- **ECP mode** - This mode provides the asynchronous bi-directional interface and transmits and receives 1-byte data using eight data signal leads under semi-duplex control by the host.

When the power is turned on, the compatibility mode is automatically selected. The change to another mode from the compatibility mode is made through negotiation. (When the BI-DIRECTION is set to ENABLE in the menu, this change can be performed.) (For the electrical/physical characteristics of this interface, see APPENDIX B).

(b) Network interface (Option)

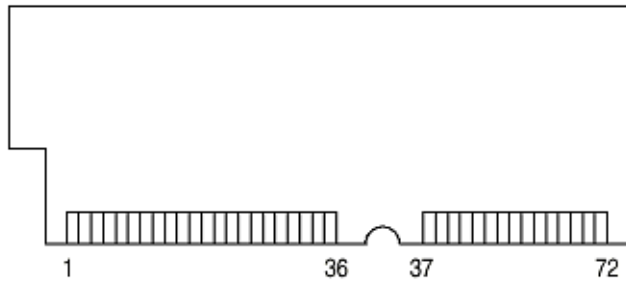
Network interface card uses the power line only.



- (9) This printer has the 2nd Cache unit which type is Write Through Cache and size is 512 KByte. There are any difference between the instruction and data. All of the CPU read/write access are cached to same 2nd cache memory.

(10) RAM module

- Pin layout



- Basic specification

Type: 72 pins SIMM (32 bits buss width)  
Access time: 60ns, 70ns, 80ns  
Capacity: 4, 8, 16, or 32  
Parity: None



2.2 Engine Control Board (PX4 PCB)  
ANALOG INPUT

(Heater temperatures and environmental humidity and temperature)

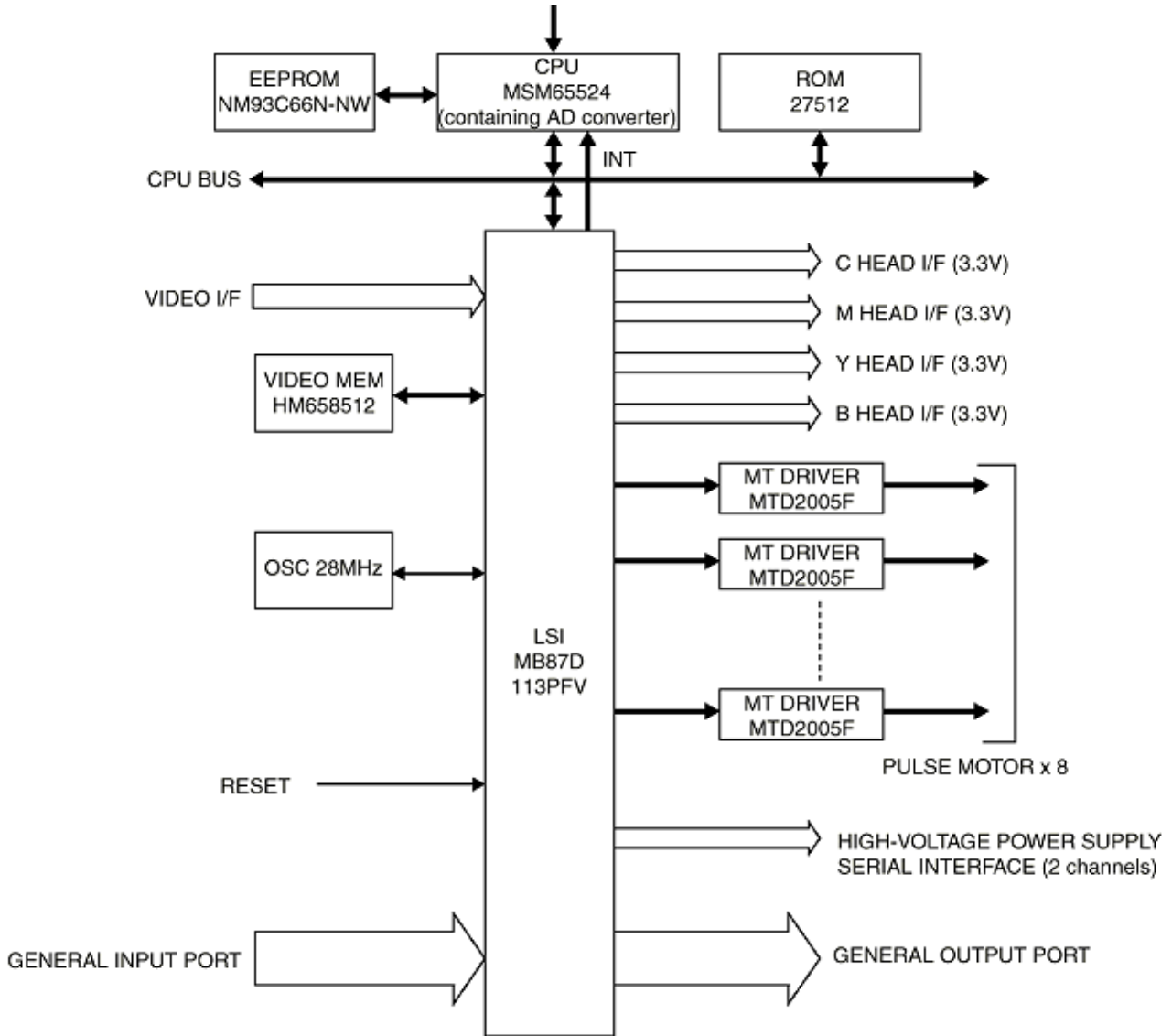


Figure 2.4

**Engine Control Board Block Diagram**

The engine control block (PU) is controlled by the engine control board (PX4 PCB) which consists of a CPU (MSM65524), general purpose LSI chips, EPROM, EEPROM, pulse motor drivers, and video memory. Refer to the Engine Control Board Block Diagram above.

- (1) **CPU**  
This is an 8-bit CPU (OKI MSM65524) containing the AD converter and controls the whole system.
- (2) **General-purpose LSI**  
This LSI (MB87D113PFV) is provided in the printer engine control block and has controller-engine video interface, LED interface, motor control, sensor input, video memory control, main scanning color correction, skew correction, high-voltage power control, and OST-EX2 functions.
- (3) **EPROM**  
This EPROM (275C512-150) has a storage capacity of 512K bits and stores programs for the PU block.
- (4) **EEPROM**  
This EEPROM (NM93C66N-NW) has a storage capacity of 4K bits. It is mounted on the board by means of IC socket and stores adjustment values.
- (5) **Pulse motor drivers**  
These drivers (MTD2005F) drive eight pulse motors for moving up and down the image drum (EP) and transferring medium.
- (6) **Video memory**  
This SRAM received print data through video interface and stores it.



### 2.3 Power/Board

The power board consists of an AC filter circuit, a low voltage power supply circuit, a high voltage power supply circuit, and heater drive circuit, and photo sensors.

#### (1) Low voltage power supply circuit.

This circuit generates the following voltages.

Output voltage	Use
+3.3 V	CU Unit CPU, LED HEAD
+5 V	Logic circuit supply voltage
+32 V	Motor and fan drive voltage and source voltage for high-voltage supply, discharge lamp
+12 V	HSP, OP Amp, high voltage power supply
-12 V	HSP

#### (2) High voltage power supply circuit

This circuit generates the following voltages necessary for electro-photographic processing from +32 V in accordance with the control sequence from the control board. When cover open state is detected, +32 V supply is automatically interrupted to stop the supply of all high-voltage outputs.

**Y M C K = Yellow, Magenta, Cyan, Black**

Output	Voltage	Use	Remarks
CH	-1.35 KV ±50V	Voltage applied to charging roller	
DB	Normal paper Y.M.C.K.: -250V/+300V, -232V/+300V (First paper: Y only) K.: -270V/+300V Transparency Y.M.C.: -200V/+300V, K.: -250V/+300V	Voltage applied to developing roller	
SB	Y.M.C.K.: -650V/0V	Voltage applied to toner supply roller	
TR	0 to 4 KV	Voltage applied to transfer roller	Variable
FIX	0 to 2.5 KV	Voltage applied to transfer roller	Variable

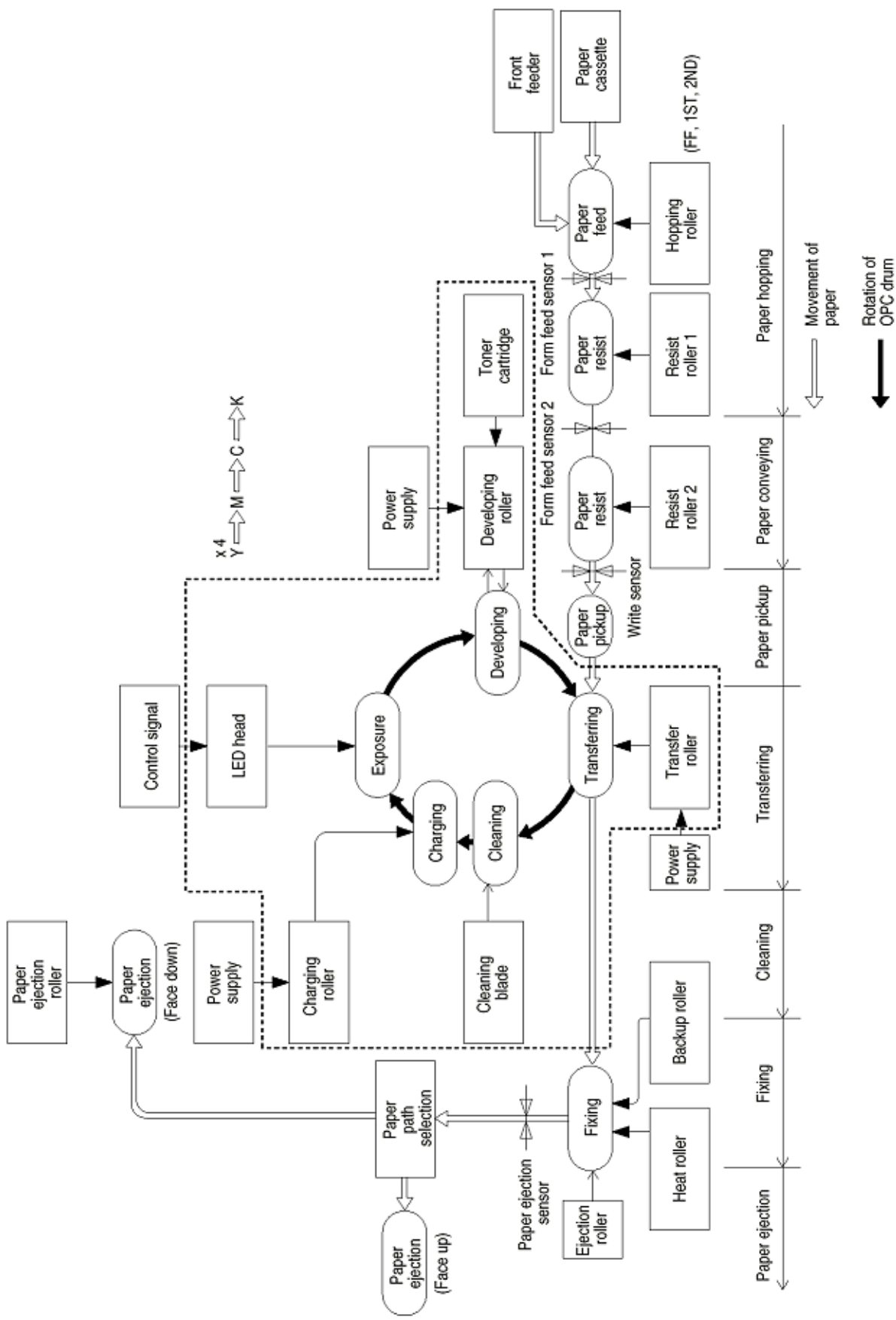




---

## **2.4 Mechanical Processes**

Here is the Mechanical Process Diagram of OKICOLOR8.



## **Mechanical Process Diagram (Figure 2.5)**

**2.4.1 Electrophotographic processing mechanism**

**2.4.2 Paper running process**

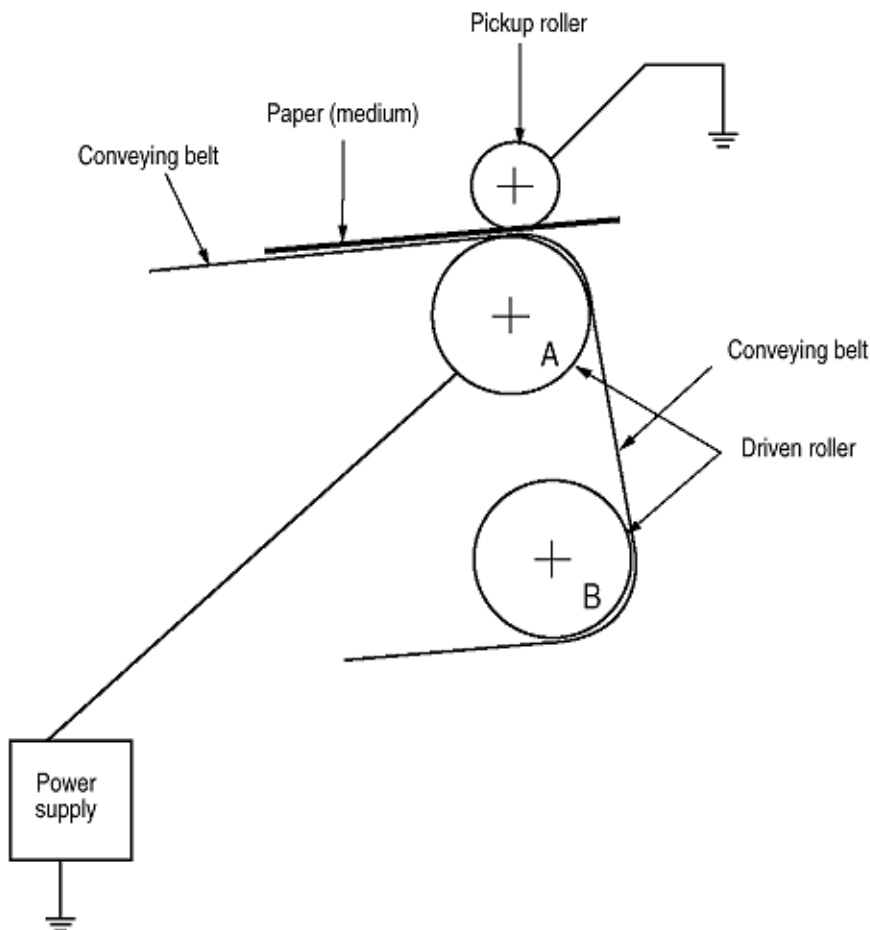
---

Copyright 1999, Okidata, Division of OKI America, Inc. All rights reserved.



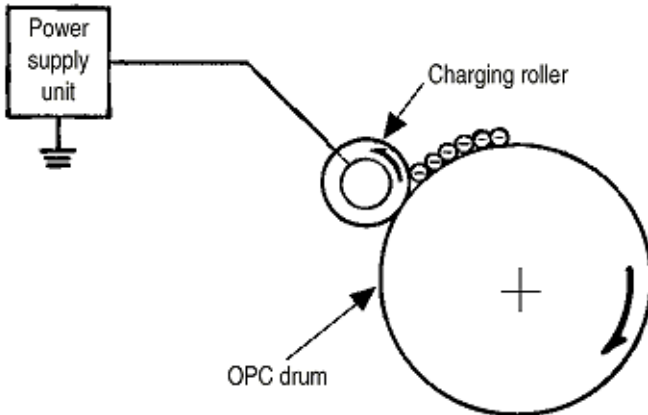
### 2.4.1 Electrophotographic processing mechanism

- (1) **Electrophotographic processes** - Each process of the electrophotographic processing mechanism is outlined below.
  - (1) **Paper pickup** - This process causes the roller to give a DC voltage to the paper, resulting in a negative charge. With this negative charge, the paper is electrostatically attracted to the roller.
  - (2) **Charging** - This process gives a DC voltage to the charge roller so that the image drum may have a uniform negative charge.
  - (3) **Exposure** - This process causes the LED head to apply light beams according to image signals to the negatively-charged surface of the image drum. The negative charge on the illuminated surface of the image drum is reduced according to magnitudes of the light beams. Thus, a latent image is formed on the surface of the image drum according to the resulting surface potentials.
  - (4) **Developing and recovery of excessive toner** - This process applies negatively-charged toner to the surface of the image drum. The toner is electrostatically attracted to the latent image to form a visible image on the surface of the image drum. Simultaneously, this process electrostatically transfers excessive toner from the image drum to the developing roller.
  - (5) **Transferring** - This process fits paper to the surface of the image drum and applies positive charge (opposite to the charge of the toner) to the back side of the paper from the transfer roller. The toner image is transferred to the paper.
  - (6) **Cleaning** - Cleaning blade scrapes off the remaining toner of any image drum, which has been used to transfer the image drum the drum to the paper.
  - (7) **Fixing** - This process fixes the toner image on the paper by pressing the fusing the image.
- (2) **Paper pickup**

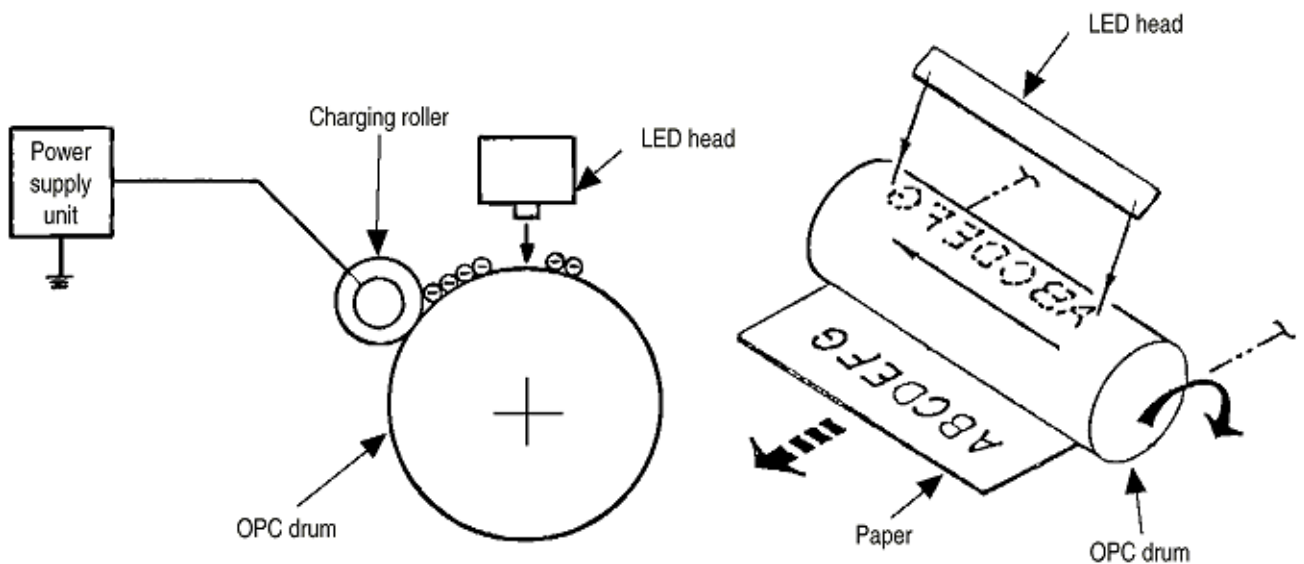


A DC voltage (0V to 2KV) is applied to the driven roller A, to create a positive charge on the lower surface of the paper. The paper is kept in charged paper is electrostatically attracted to the pickup roller. The paper is in close contact with the conveying Belt and moves steadily.

**(3) Charging** - This process applies a DC voltage to the charging roller in contact with the surface of the image drum.

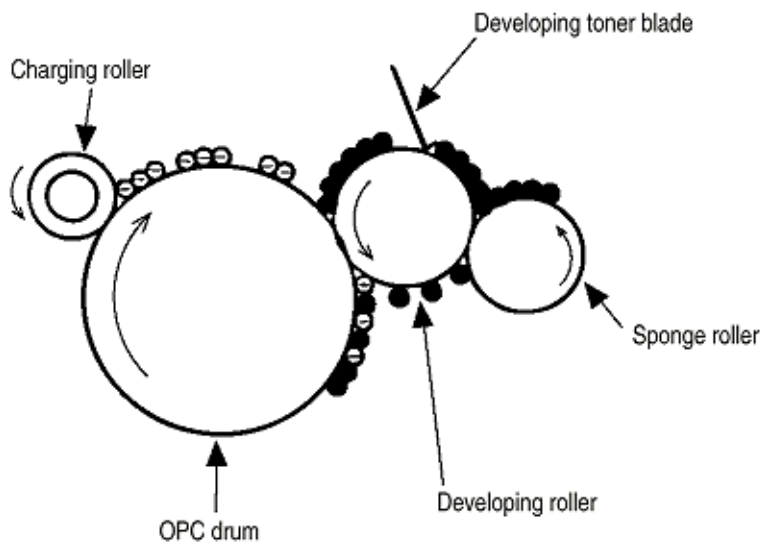


**(4) Exposure** - The light beams from the LED head are applied to the surface of the image drum which is charged negatively. The negative charge on the illuminated surface of the image drum is reduced according to the magnitude of the light beams and a latent image is formed on the surface of the image drum according to the resulting surface potentials.



**(5) Developing** - This process applies toner to the latent image on the surface of the drum to create a toner image. Developing is carried out on the surface of the image drum at where the image contacts with the developing roller.

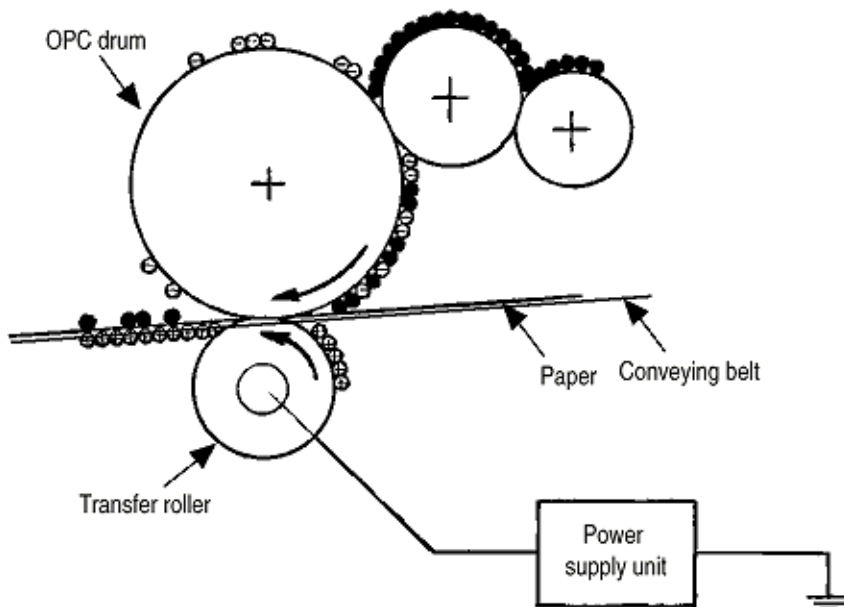
(1) The sponge roller transfers toner to the developing roller. The toner is charged negatively.



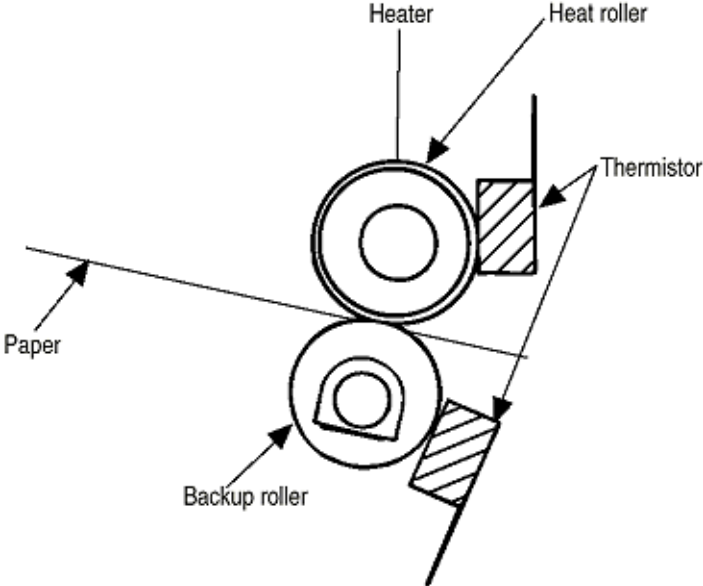
(2) The toner blade scrapes away excess toner from the developing roller, leaving a thin film of toner on the surface of the developing roller.

(3) The toner is attracted to the latent image on the surface of the image drum, where the image drum contacts the developing roller. The latent image on the surface of the image drum is made visible with the toner.

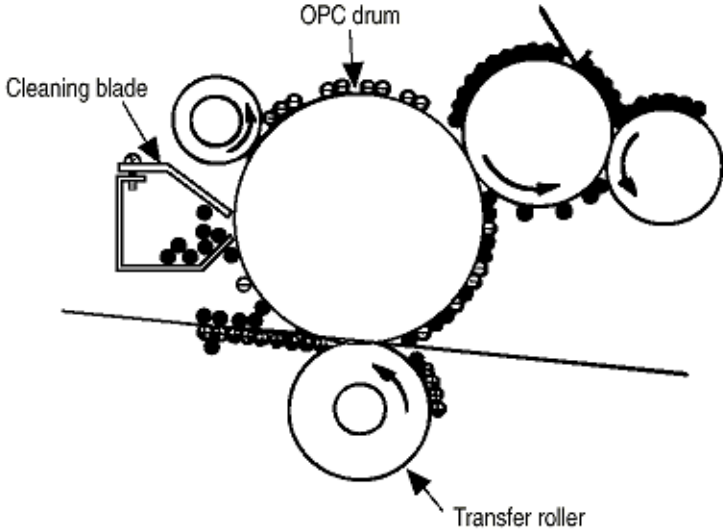
**(6) Transferring** - The transfer roller made of conductive sponge presses the paper against the surface of the image drum. The paper will make close contact with the surface of the image drum. This process fits the paper to the surface of the image drum (using the transfer roller) and applies a positive charge (opposite to the charge of the toner) from under the paper. When a positive high voltage is applied to the transfer roller from the power supply, the positive charge induced on the transfer roller jumps to the upper surface of the paper (where the transfer roller touches the paper) and attracts the negatively-charged toner from the surface of the image drum onto the surface of the paper.



**(7) Fixing** - The toner image just transferred to the paper is fused and fixed to the paper while the paper is passing through the gap between the heat roller and the backup roller. The teflon-coated surface of the heat roller is heated by the 800-watt heater (or a halogen lamp) in the heat roller. The temperature of the heat roller surface is controlled by a thermistor in contact with the surface of the heat roller. A thermostat is provided for safety. When the heat roller temperature rises above the preset temperature, the thermostat opens and shuts off power to the heater in the heat roller. The backup roller is evenly pushed against the heat roller by two end springs.



**(8) Cleaning** - The toner which remains on the (OPC) Image Drum without being fused is scraped by a cleaning blade and discarded in the waste toner tank.





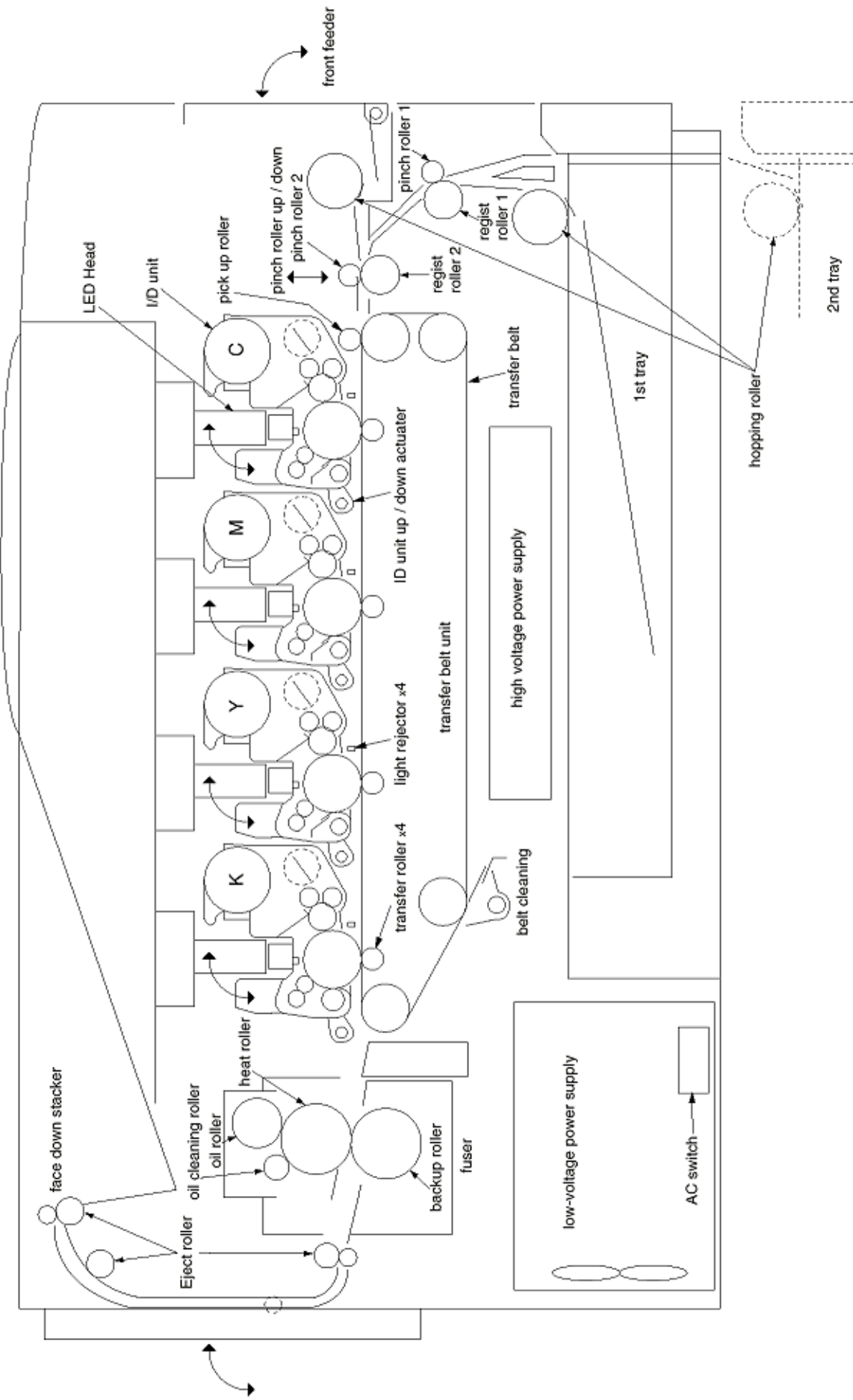
---

### **2.4.2 Paper running process**

How paper moves through the OKICOLOR8 is shown in the Paper Route Diagram.

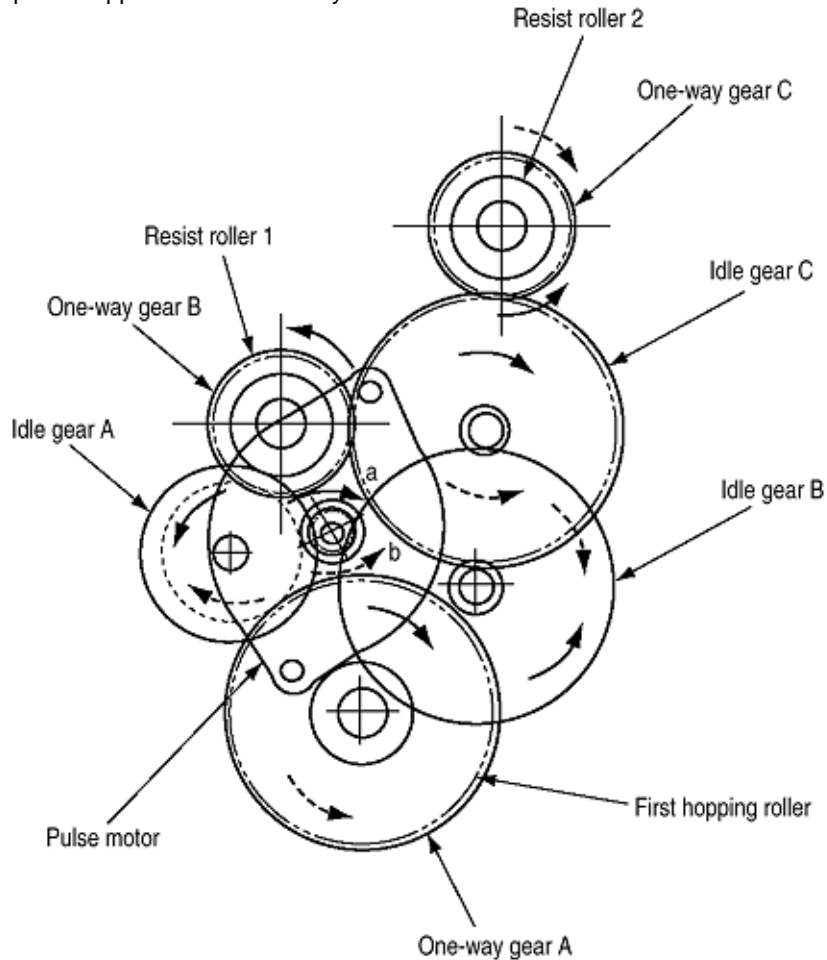
**Y=Yellow; M=Magenta; C=Cyan; K=Black**





### (1) Paper hopping and transfer and up/down movement of pinch roller 2

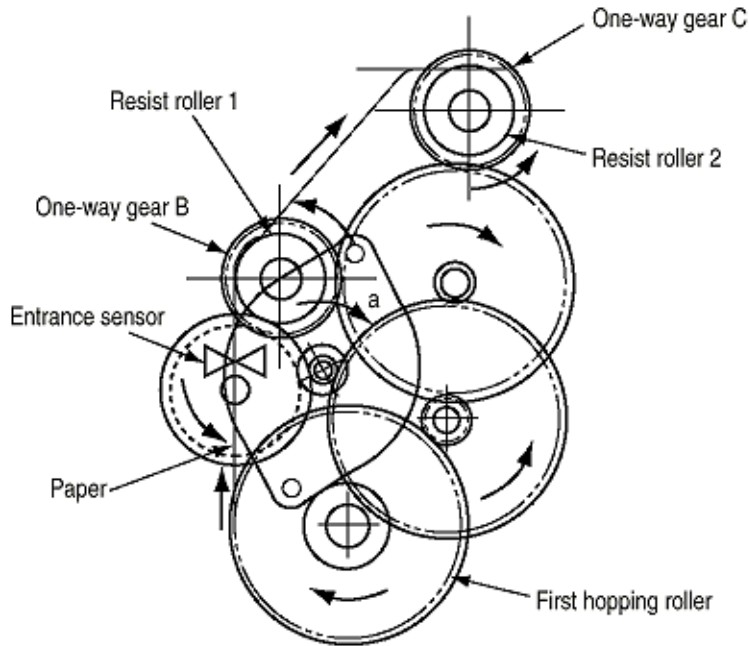
Paper is hopped and delivered by the mechanism shown below. This mechanism is driven by a single pulse motor.



The pulse motor turns in the arrow direction (a) and drives the hopping roller in the direction of "b". The hopping roller drives the resist roller. Gears A, B, and C, have one-way clutches to prevent the roller from rotating reversely.

#### a) Hopping

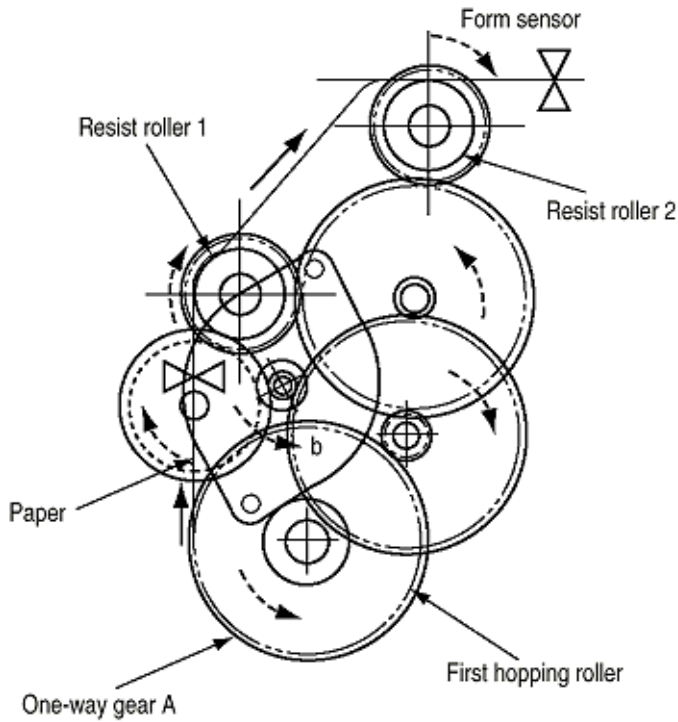
- (1) The pulse motor turns in the arrow direction of "a" (counterclockwise) and drives the hopping roller to move the paper until the Entrance sensor turns on. Although the one-way gears B and C are driven, the resist roller 2 does not turn. The reverse rotations of the one-way clutch gears are not transmitted to the resist roller.
- (2) After the Entrance sensor turns on, the hopping roller keeps on feeding the paper until it hits the resist roller 1. This operation corrects any paper skew.



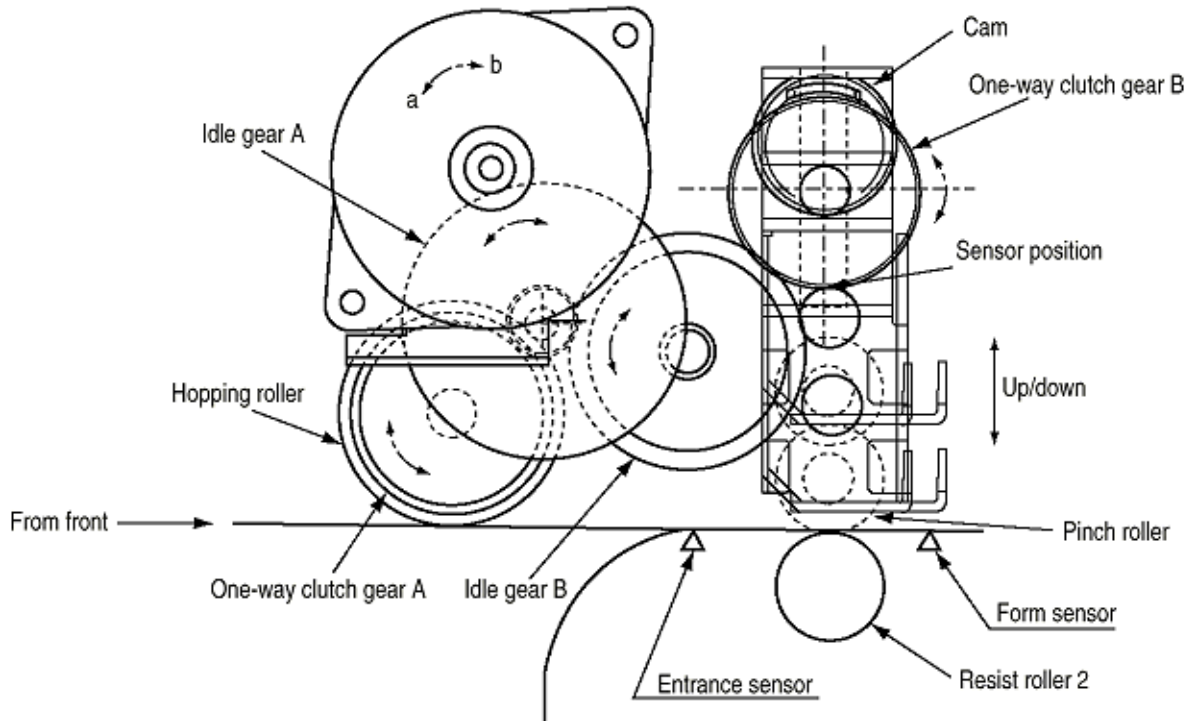
**b) Conveying**

(1) After paper hopping is completed, the pulse motor turns right (in the direction of "b") to drive the resist rollers 1 and 2. The resist rollers feed the paper until the Form sensor turns on. Although the one-way gear A is also driven, the hopping roller does not turn because of the one-way clutch.

(2) The paper is further fed in synchronism with the print data.



(2) The hopping operation of the front feeder and the up/down operation of the pinch roller 2 are performed by a single pulse motor.

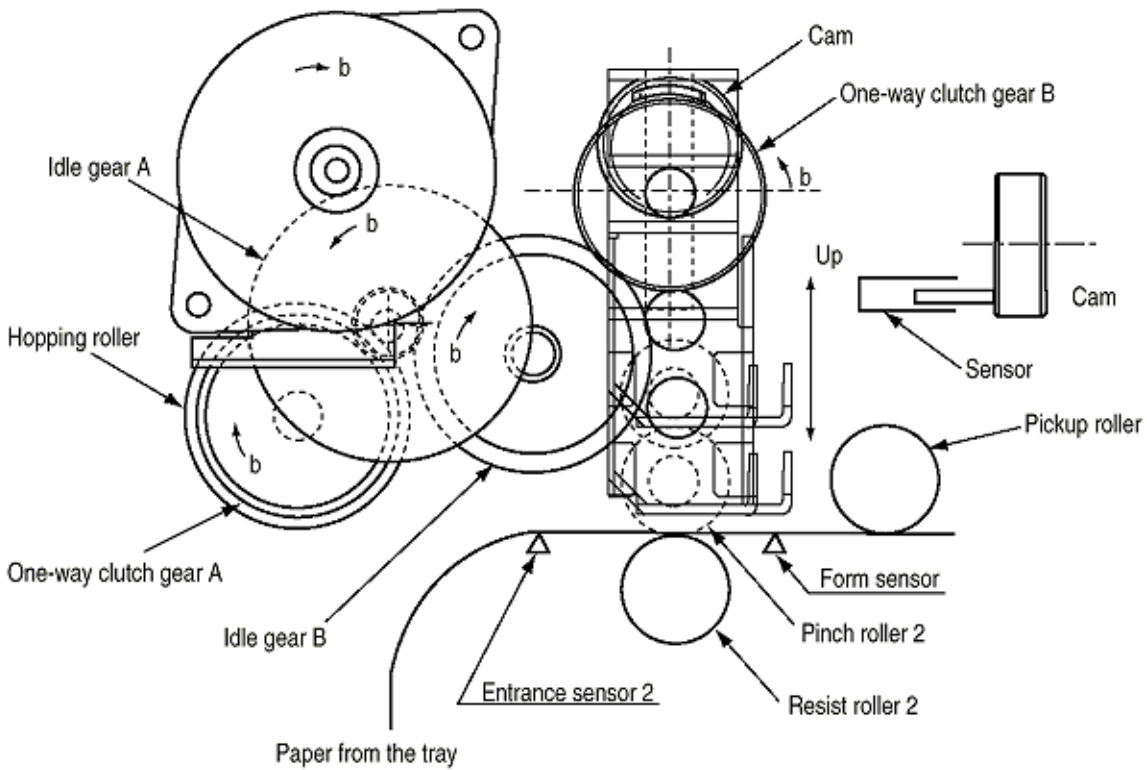


When the pulse motor of the front feeder turns right (in the direction of "A"), the front hopping roller turns left (in the direction of "b") to drive the cam. This cam moves up and down the pinch roller 2. The one-way clutch gears are made to turn only in a present direction by means of the one-way clutches.

**(a) First and second hopping rollers**

1 When the front edge of the paper passes by the pickup roller, the pulse motor of the front feeder turns counter-clockwise (in the direction of "b" to drive the cam. The cam moves up the pinch roller 2. Although the one-way clutch gear A is also rotating, the hopping roller of the front feeder does not rotate (because of the one-way clutch).

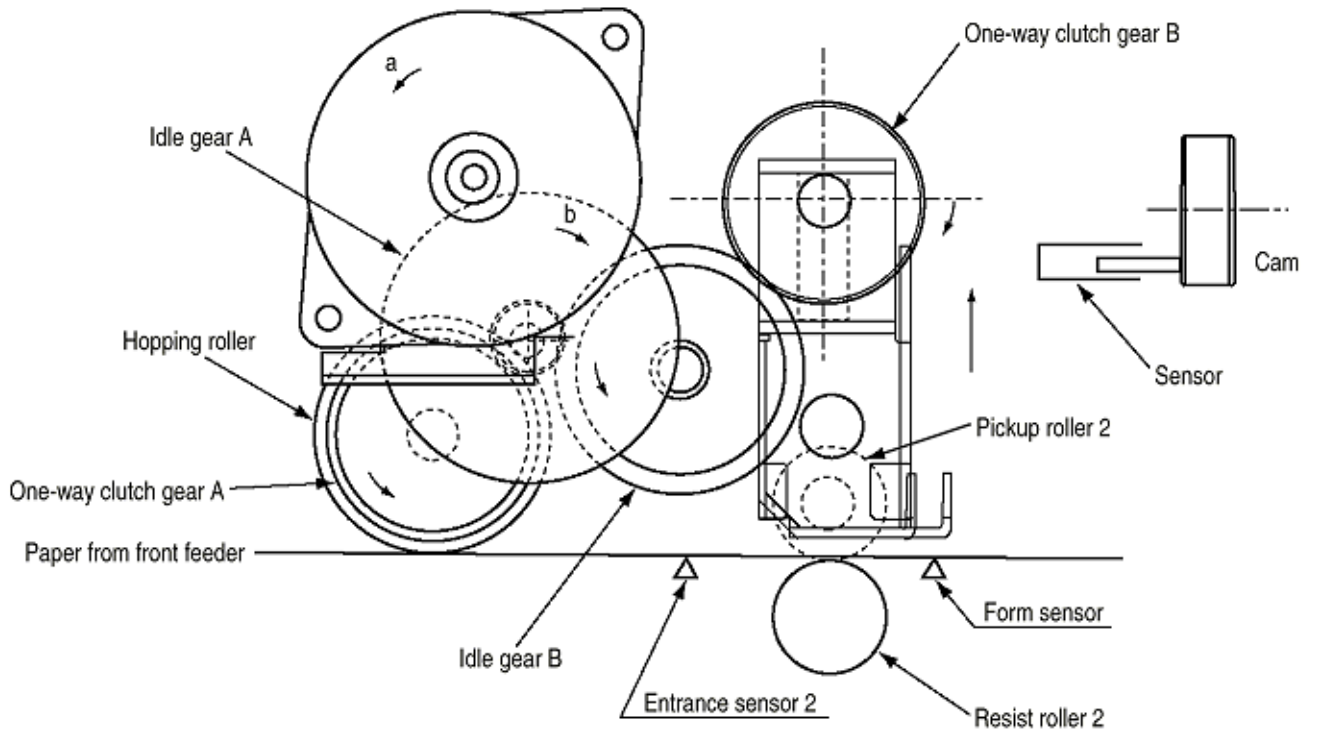
2 When the rear edge of the paper passes by the Entrance sensor 2, the pulse motor of the front feeder turns counter-clockwise (in the direction of "b") to drive the cam. The cam moves down the pinch roller 2 until it is sensed by the sensor. Although the one-way clutch gear A is also rotating, the hopping roller of the front feeder does not rotate (because of the one-way clutch).



**(b) Front feeding hopping**

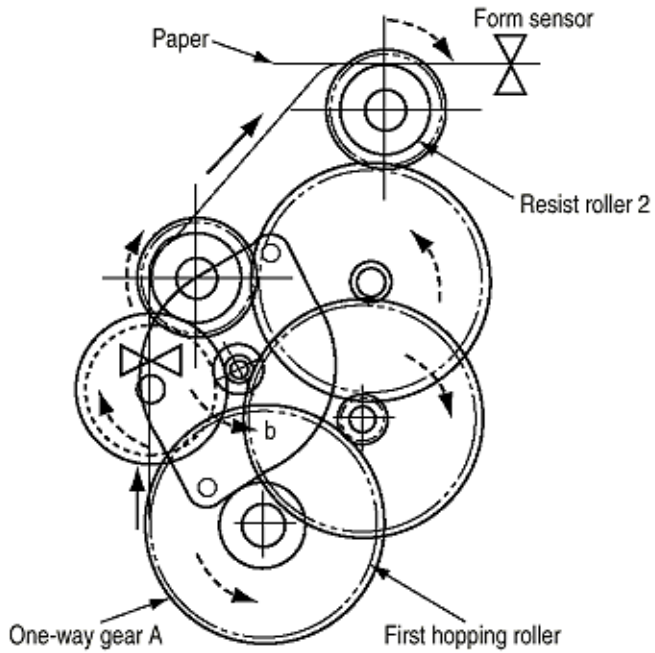
(1) The pulse motor of the front feeder turns right (in the direction of "a") to drive the hopping roller. The paper feeds until the Entrance sensor 2 is activated. Although the one-way clutch gear B is also rotating, the pinch roller 2 does not drive the up/down cam (because of the one-way clutch). After the Entrance sensor is activated, the paper feeds until it reaches the resist roller.

(2) This operation corrects any paper skew.



**(c) Conveying**

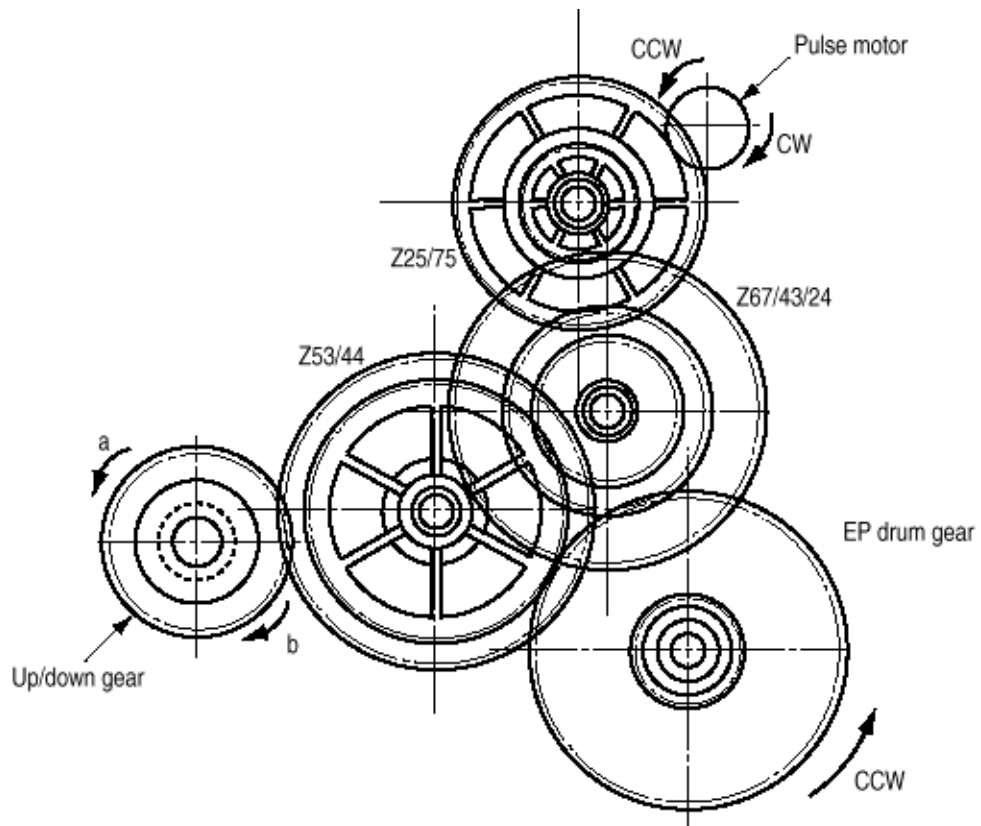
- (1) After paper hopping is completed, the pulse motor turns right (in the direction of "b") to drive the resist rollers 1 and 2. The resist rollers feed the paper until the Form sensor turns on.
- (2) Although the one-way gear A is also driven, the first hoping roller does not turn (because of the one-way clutch).



**(2) Up/down movement of the image drum unit and rotation of the image drum.**

The up/down movement of the image drum unit and the rotation of the image drum are performed by a mechanism shown below. (See Figure 2.6-a). This mechanism is driven by a single pulse motor.

When the pulse motor turns left (Counter-clockwise), the up/down gear turns left (in the direction of "a"), and the up/down lever (see Figure 2.6-b) moves up (in the direction of "a"). The up/down lever pushes up the up/down actuator of the image drum unit. The image drum unit moves up as shown in Figure 2.6-b). The image drum rotates freely.



When the pulse motor (see Figure 2.6-a) turns right (Counter-clockwise), the image drum gear turns left (Counter-clockwise) and the up/down gear (one-way gear) is released. The weight of the image drum unit is applied to the up/down lever via the up/down actuator of the image drum unit. The free up/down gear turns right (in the direction "b" in Figure 2.6-a), and the image drum unit goes down until the up/down actuator of the image drum unit is stopped by the up/down lever. (See Figure 2.6-c). During this, the image is transferred onto the running paper.



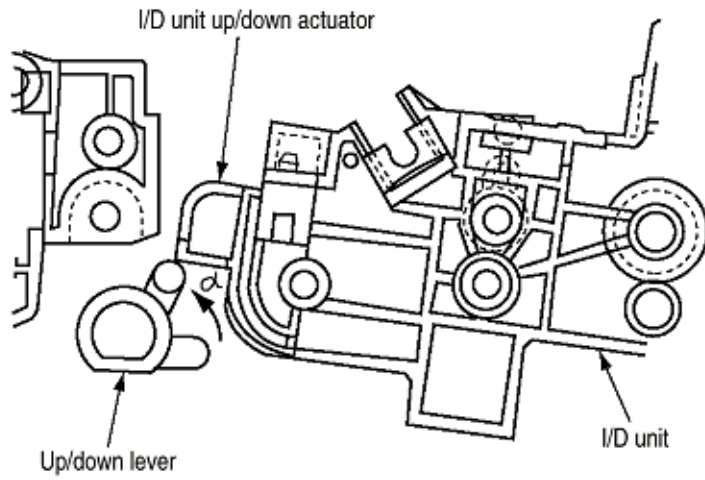


Figure 2.6-b

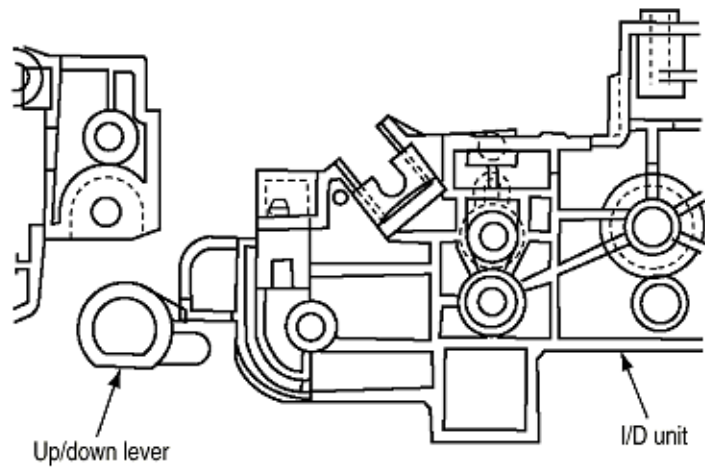
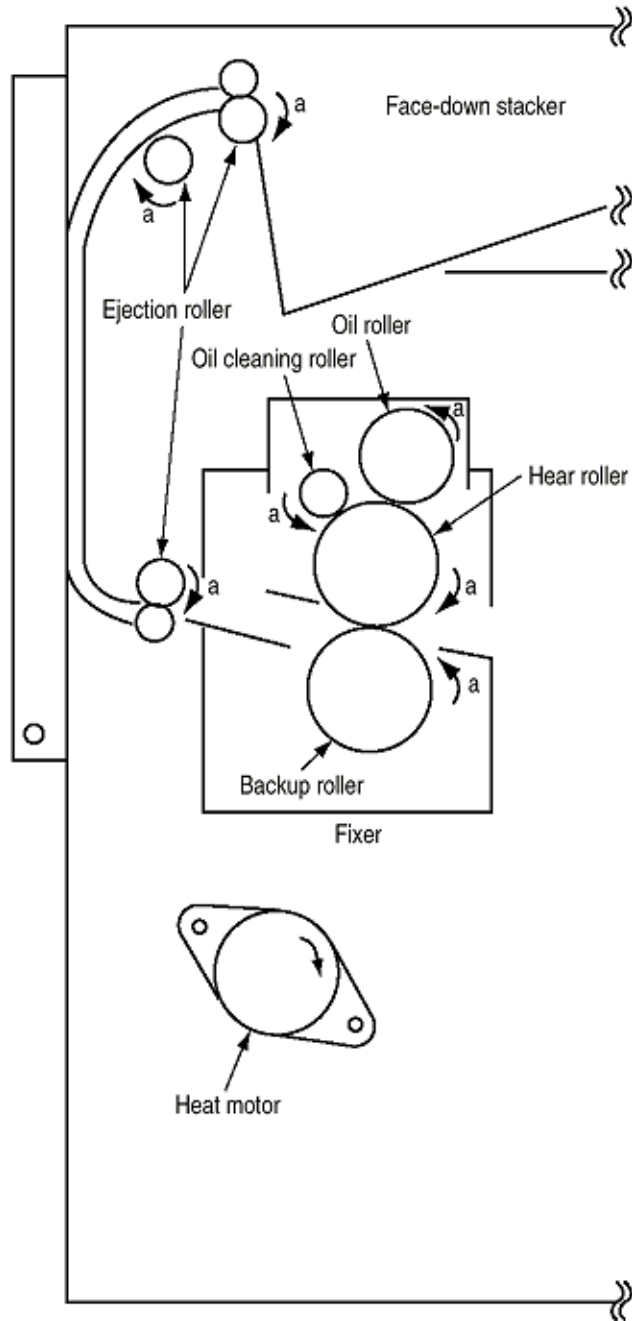


Figure 2.6-c

(3) Lubrication and cleaning of fixing, ejecting, and heat rollers.



The fixing roller, the ejecting roller, and the heat roller are lubricated and cleaned by a single pulse motor.

When the heat roller pulse motor turns right (in the direction of "a"), the heat roller and the backup roller turn left (in the direction of "a") to fix a toner image onto the paper.

At the same time, three ejection rollers turn right (in the direction of "a") to eject the paper. The oil roller and the oil cleaning roller turn left (in the direction of "a") to supply oil to the surface of the heat roller and clean the surface.

Copyright 1999, Okidata, Division of OKI America, Inc. All rights reserved.



---

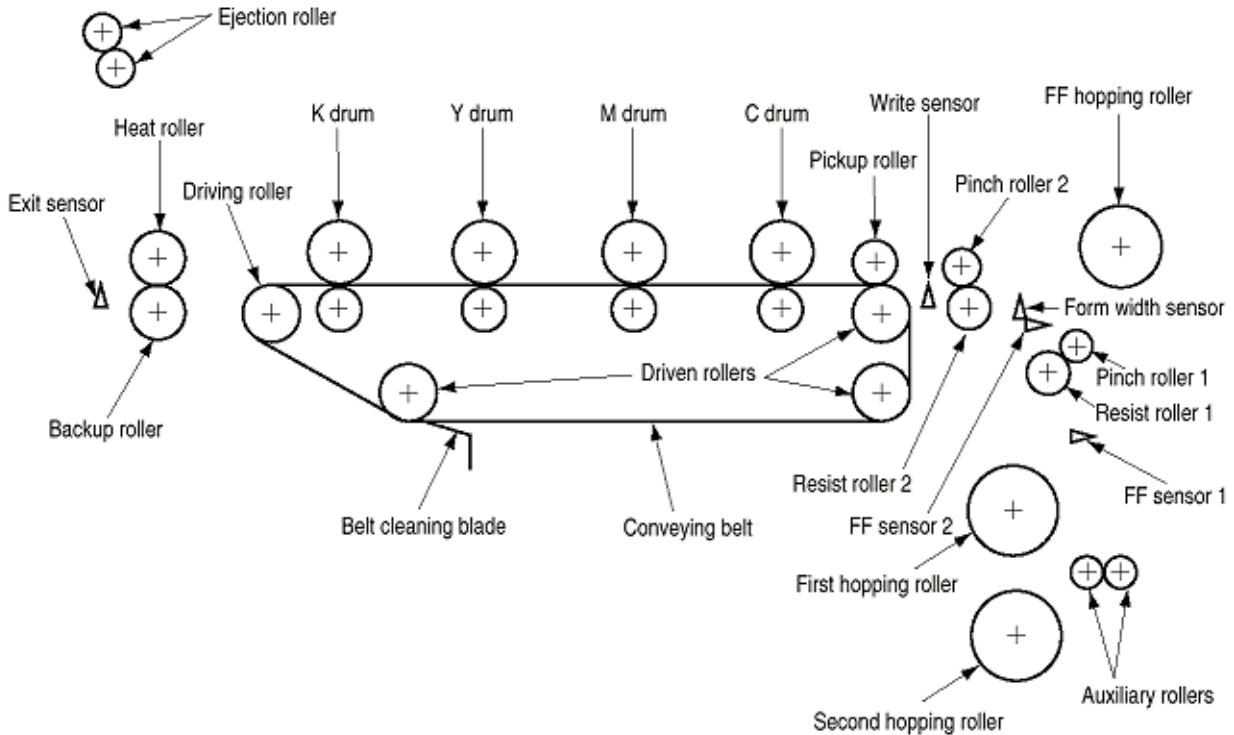
**2.5 Sensors**

**2.5.1 Paper related sensors**

**2.5.2 Other sensors**



**2.5.1 Paper Related Sensors**



Sensor	Function	Sensor status
FF sensor 1/2 (Entrance sensor 1/2)	Detects the front edge of an incoming paper and determines timing to change from hopping to conveying.	ON: Front edge detected OFF: Front edge not detected
Write sensor	Detects the front edge of the conveyed paper sheet and determines the length of the paper sheet from elapsed time before the front edge of the paper reaches the sensor.	ON: Form present OFF: Form absent
Ejection sensor	Detects the front and rear edges of a paper sheet and determines whether the paper is ejected.	ON: Form present OFF: Form ejected



---

### 2.5.2 Other sensors

- (1) **Form end sensor**  
This sensor checks whether the paper cassette is empty.
- (2) **Front Feeder form end sensor**  
This sensor checks whether the front feeder has paper.
- (3) **Front Feeder home switch**  
The microswitch checks whether the front feeder stage is in the up or down position.
- (4) **Image Drum**  
Image drum up/down sensor (one for each color C, M, Y, K)  
C = Cyan, M = Magenta, Y = Yellow, K = Black
- (5) **Waste toner sensor**  
This sensor judges whether the waste toner cartridge is full by measuring a time period at which the sensor lever turns on periodically. When the time period falls under a preset value, the system judges that the waste toner cartridge is full and displays the "waste toner full" message.
- (6) **Resist up/down sensor**  
This sensor detects the up or down position of the resist roller 2.
- (7) **Temperature sensor**  
Refer to 2.7 (Transfer Control according to Environmental Changes)
- (8) **Humidity sensor**  
Refer to 2.7 (Transfer Control according to Environmental Changes)



---

### **2.6 Correction of Color Deviation**

OKICOLOR8 is equipped with an array of I/D units which cannot be from generation of color deviations. This mechanically caused color deviation is corrected electronically as shown below.

#### **(1) Color deviations to be corrected**

- 1 Color deviation in the X axis (Positional error of the LED head)
- 2 Diagonal color deviation (Positional error of the LED head)
- 3 Color deviation in the Y axis (Positional errors of the I/D units and light receivers)

**(2) Method of correction** Print out the preset color chart, compare the printed color chart by the original color chart, and enter the amount of color deviation of each color from the operator panel or from the host computer. OKICOLOR8 calculates correction values from the entered values and changes the write timing of each color (cyan, magenta, and yellow) relative to black.



---

### **2.7 Transfer Control according to Environmental Changes**

Transfer Control according to Environmental Changes (Room Temperatures and Relative Humidities)

OKICOLOR8 measures the room temperature and humidity. It uses a room temperature sensor and a room humidity sensor. An optimum transfer voltage is calculated, using the obtained environmental conditions. The unit then prints, using the optimum transfer voltage.



**2.8 Form Jam Detection**

OKICOLOR8 checks for a paper jam when the page printer is powered on, and during printing. When a paper jam is found, the OKICOLOR8 immediately stops the printing process. To recover the printer, open the cover, find and remove the jammed paper, then close the cover.

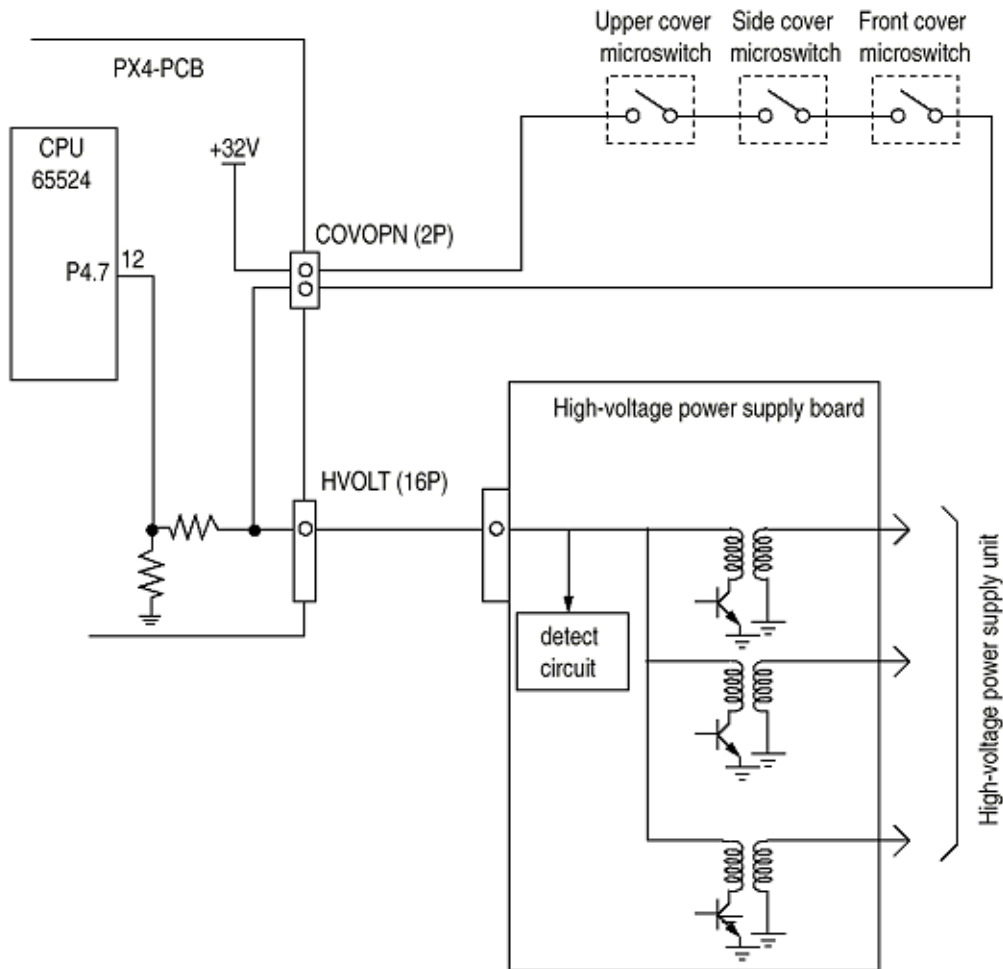
<b>Error</b>	<b>Conditions</b>
<b>Form feed jam</b>	Three hopping operations are made, but the Form Feed sensor (Entrance) does not turn on within a preset time after the Form Feed sensor 1 turns on.
<b>Convey jam</b>	The ejection sensor does not turn on within a preset time period after the Write sensor detects the front end of paper.
<b>Ejection jam</b>	The eject sensor detected the front edge of the paper, but does not detect the rear edge of the paper within a preset time period.
<b>Form size error</b>	The form size (obtained by measuring the time period between the rear edge of the paper passes by the Form Feed sensor 2 after the front edge of the paper passed the Write sensor) is longer by 45mm than the specified form length.





**2.9 Cover Opening**

When the upper, side, or front cover of the OKICOLOR8 is opened, the Cover open microswitch turns off, the voltage of 32V to the high-voltage power supply is shut off, and all high-voltage outputs are shut off. At the same time, the CPU receives a signal (CVOPN), (indicating the status of the microswitch), and performs the cover open process.

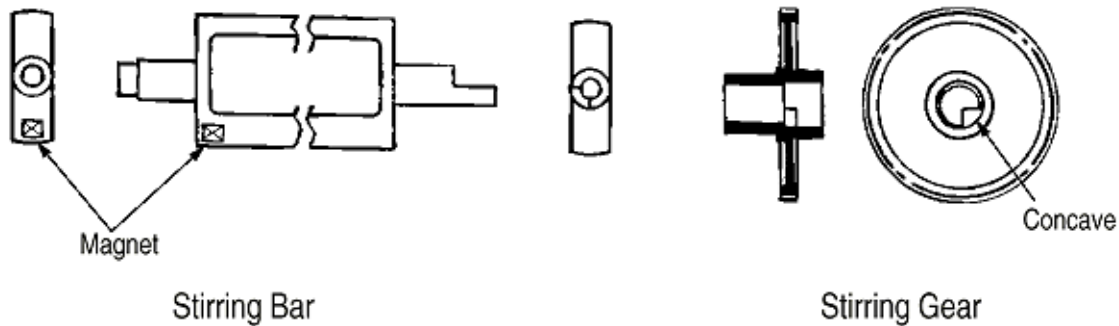




## 2.10 Toner Lower Detection

- **Composition**

The device consists of the stirring gear (which rotates at a constant rate), the stirring bar, and the magnet on the stirring bar. The stirring bar rotates by engaging with the concave section in the stirring gear.

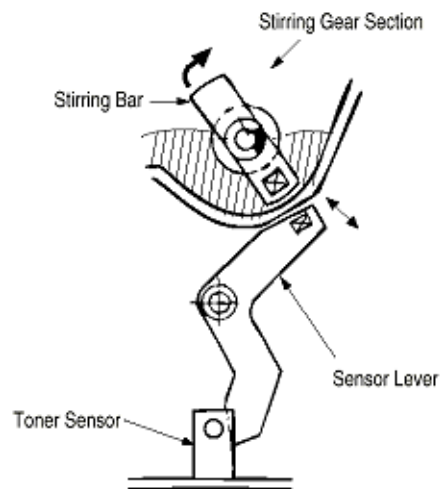


- **Operation**

Toner Low is detected by monitoring the time interval between engagement of the magnet set on the sensor lever and the magnet on the stirring bar.

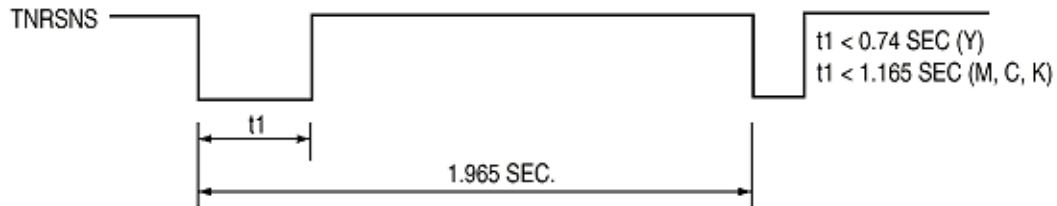
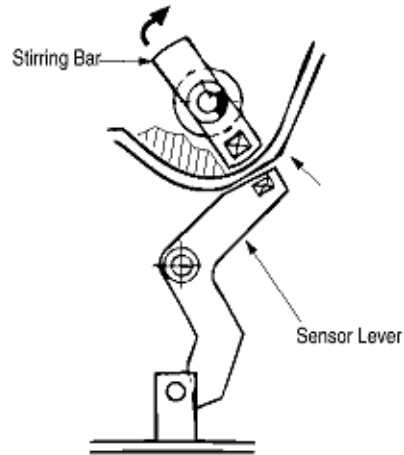
### OPERATION during toner full state

- The stirring bar rotates by interlocking with the stirring gear.
- When the magnet on the stirring bar reaches its maximum height, the other end of the bar is dipped in the toner. The stirring bar is pushed by the stirring gear.

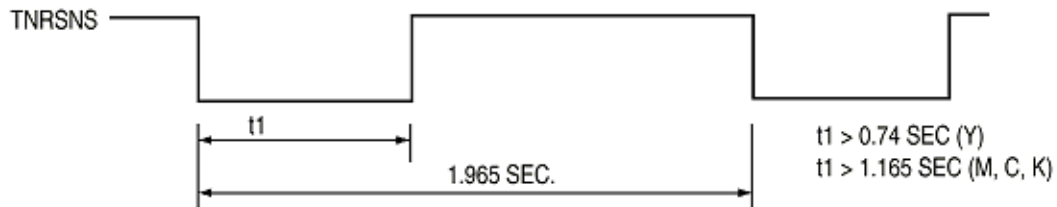


### Operation during toner low state

- When the stirring bar reaches the maximum height, the lack of toner provides no resistance on the other end. The bar falls to the minimum height, due to its own weight.
- The time length of the encounter (between the stirring bar magnet and the sensor lever magnet), counter with the magnet of the sensor lever becomes long. By monitoring this time interval, toner low is detected.



### TONER LOW state



- When the toner low state is detected 2 times consecutively, Toner Low is established.
- When the toner full state is detected 2 times consecutively, Toner Low is canceled.
- When there is no change with the toner sensor for 2 cycles (1.965 sec. x 2) or more, the Toner Sensor Alarm is activated.
- The toner sensor is not monitored while the drum motor is in halt.



**2.11 Page Size Detection**

The four tab pieces are driven according to the setting position of the paper guide (through the cam interlocked with the paper guide of the paper cassette).

When the paper cassette is inserted into the printer, the position of the tab pieces is detected by a microswitch, recognizing the paper size.

**STATE OF MICROSWITCHES**

SW1	SW2	SW3	SW4	Paper size
0	1	1	1	Letter
0	1	0	1	Executive
0	0	1	1	A4
1	1	1	0	Legal 14
1	0	1	1	Legal 13
1	1	0	1	B5
1	1	0	0	A5
1	0	0	1	A6



---

## 2.12 Power-on Processing

### 2.12.1 Self-diagnostic test

(1) **Initial test**

The following check are automatically performed when the printer is power on:

- (a) ROM check
- (b) RAM check
- (c) EEPROM check
- (d) Flash ROM check

(2) **ROM check**

(a) Checks ROM by comparing the sum of bits in the received data unit by the number of bits in the transferred data unit.

(3) **RAM check**

- (a) Checks RAM by writing a preset data patten in RAM, reading the contents of RAM, and comparing the data read from RAM by the data written in RAM. (Write-read test).
- (b) Checks optional RAM (if it is installed).
- (c) Checks resident RAM by exclusively O Ring high and low addresses (to prepare 16-bit data units), writing a preset 16-bit data patten in RAM, reading the contents of RAM, and comparing the data read from RAM by the data written in RAM. Checks optional RAM by writing and reading 32-bit fixed patterns ("5555h" and "aaaah") in optional RAM.

(4) **EEPROM check**

- (a) Checks identification numbers stored in the fixed addresses of EEPROM.
- (b) Checks the contents of the menu area (by control firmware) and the engine area (by engine firmware).

(5) **Flash ROM check**

Checks Flash ROM by writing a present data pattern in Flash ROM, reading the contents of Flash ROM, and comparing the data read from Flash ROM by the data written in Flash ROM. (Write-read test).

(6) **Option check unit**

Checks whether the optional units (such as the second tray, and PS SIMM) have been installed before entering the operation mode.



---

**3.0 Parts Replacement**

**3.1 Precautions for Parts Replacement**

**3.2 Parts Layout**

**3.3 How to Change Parts**



**3.1 Precautions for Parts Replacement**

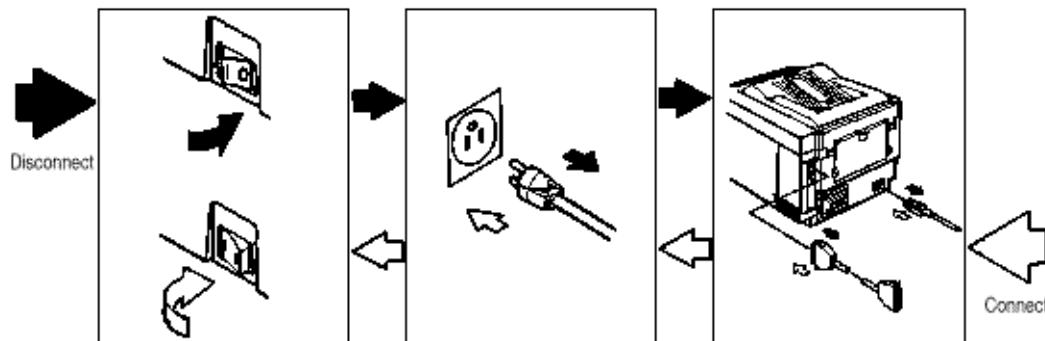
(1) Before starting parts replacement, remove the AC cable and interface cable.

**(a) Removing the AC cable**

- i) Turn off ("o") the power switch of the printer.
- ii) Disconnect the AC inlet plug of the AC cable from the AC receptacle.
- iii) Disconnect the AC cable and interface cable from the printer.





**(b) Reconnecting the AC cable**

- i) Connect the AC cable and interface cable to the printer.
- ii) Connect the AC inlet plug to the AC receptacle.
- iii) Turn on ("I") the power switch of the printer.



- (2) Do not disassemble the printer, if operating normally.
- (3) Do not remove unnecessary parts: try to keep disassembly to a minimum.
- (4) Use specified service tools.
- (5) When disassembling, follow the determined sequence. Otherwise, parts may be damaged.
- (6) Since screws, collars and other small parts are likely to be lost, they should temporarily be attached to the original positions.
- (7) When handling ICs such as microprocessors, ROM and RAM, and circuit boards, follow standard electrostatic procedures.
- (8) Do not place printed circuit boards directly on the equipment or floor.

No.	Service Tools	Tools	Qty	Place of Use	Remarks
1		No. 1-100 Philips screwdriver	1	2-2.5 mm screws	
2		No. 2-200 Philips screwdriver, Magnetized	1	3-5 mm screws	
3		No. 3-100 screwdriver	1		
4		No. 5-200 screwdriver	1		

5		Digital multimeter	1		
6		Pliers	1		
7		Handy cleaner	1		
8		LED Head cleaner P/N 51802901	1	Cleans LED head	

---

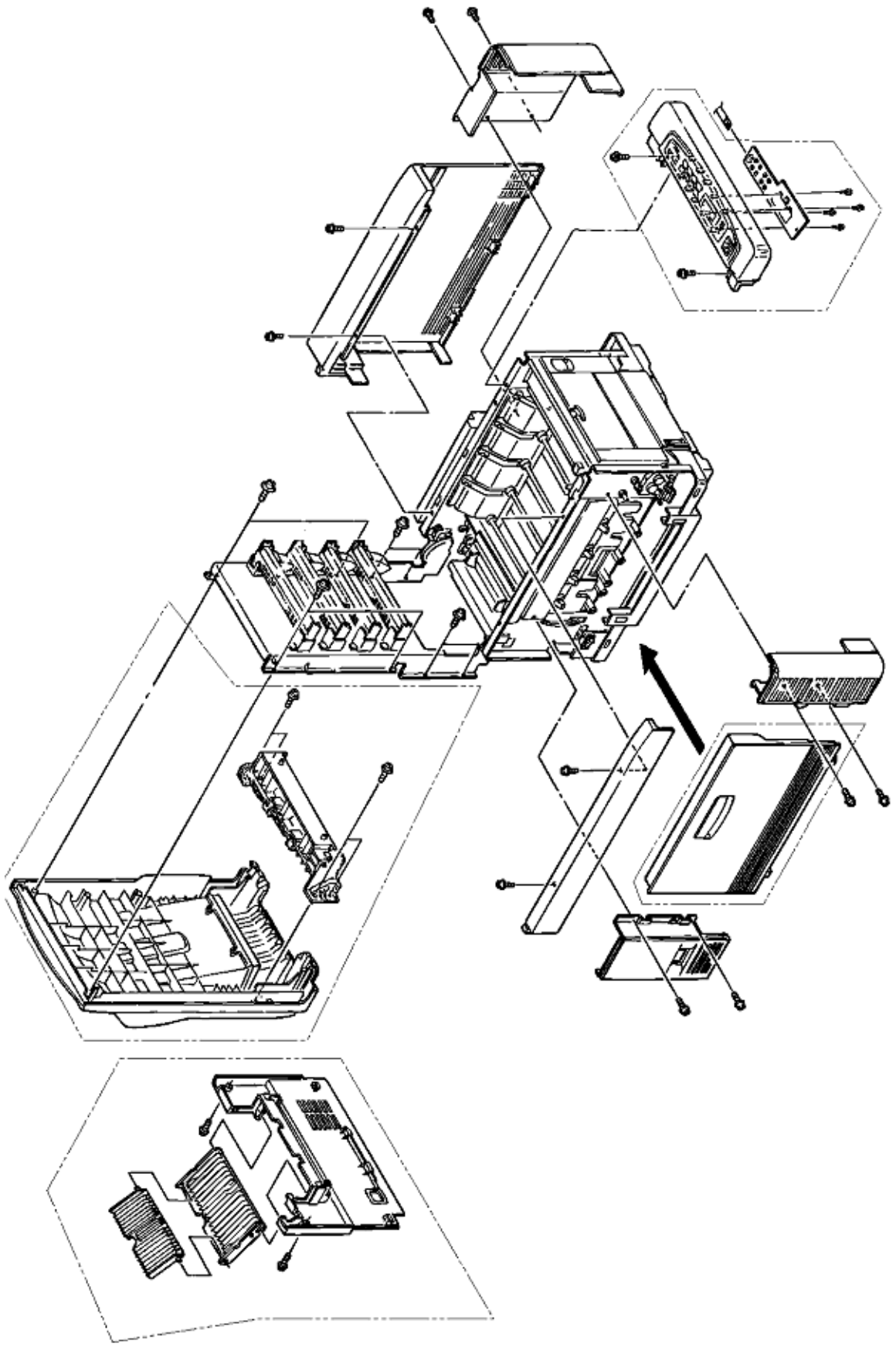
Copyright 1999, Okidata, Division of OKI America, Inc. All rights reserved.





---

**3.2 Parts Layout**



**Figure 3-1, Covers**

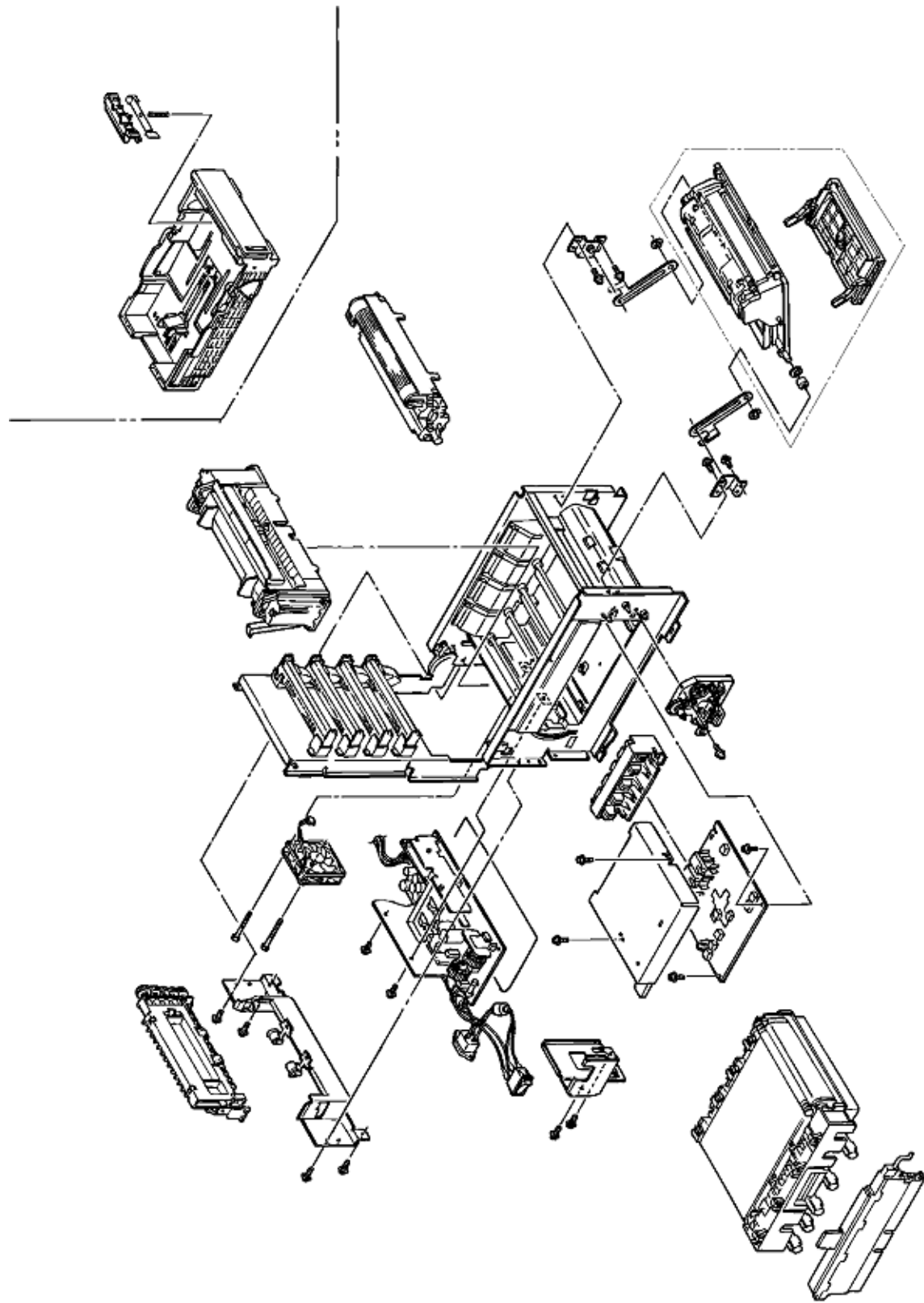


Figure 3-2, Print Assemblies

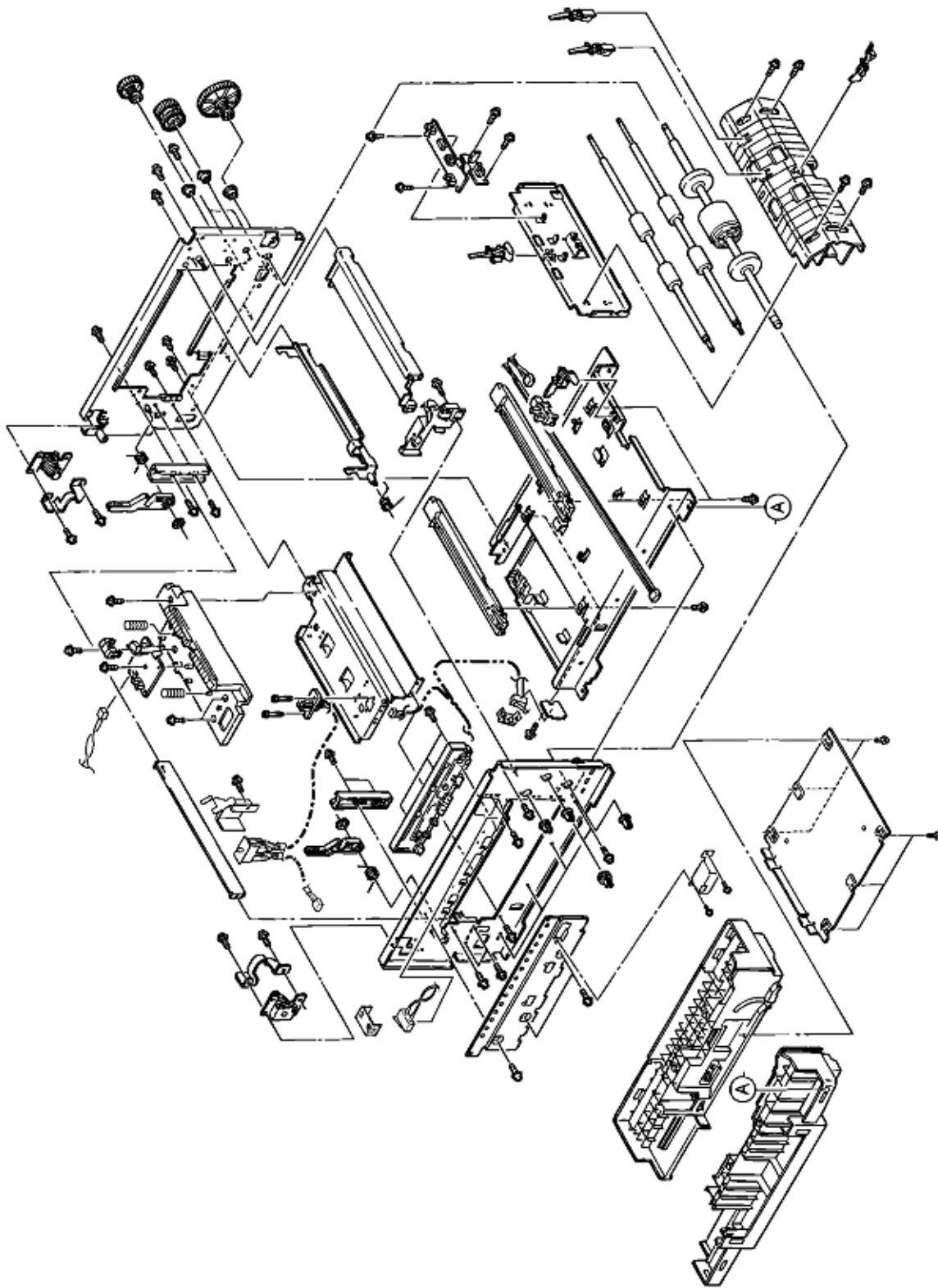


Figure 3-3, Base Assemblies

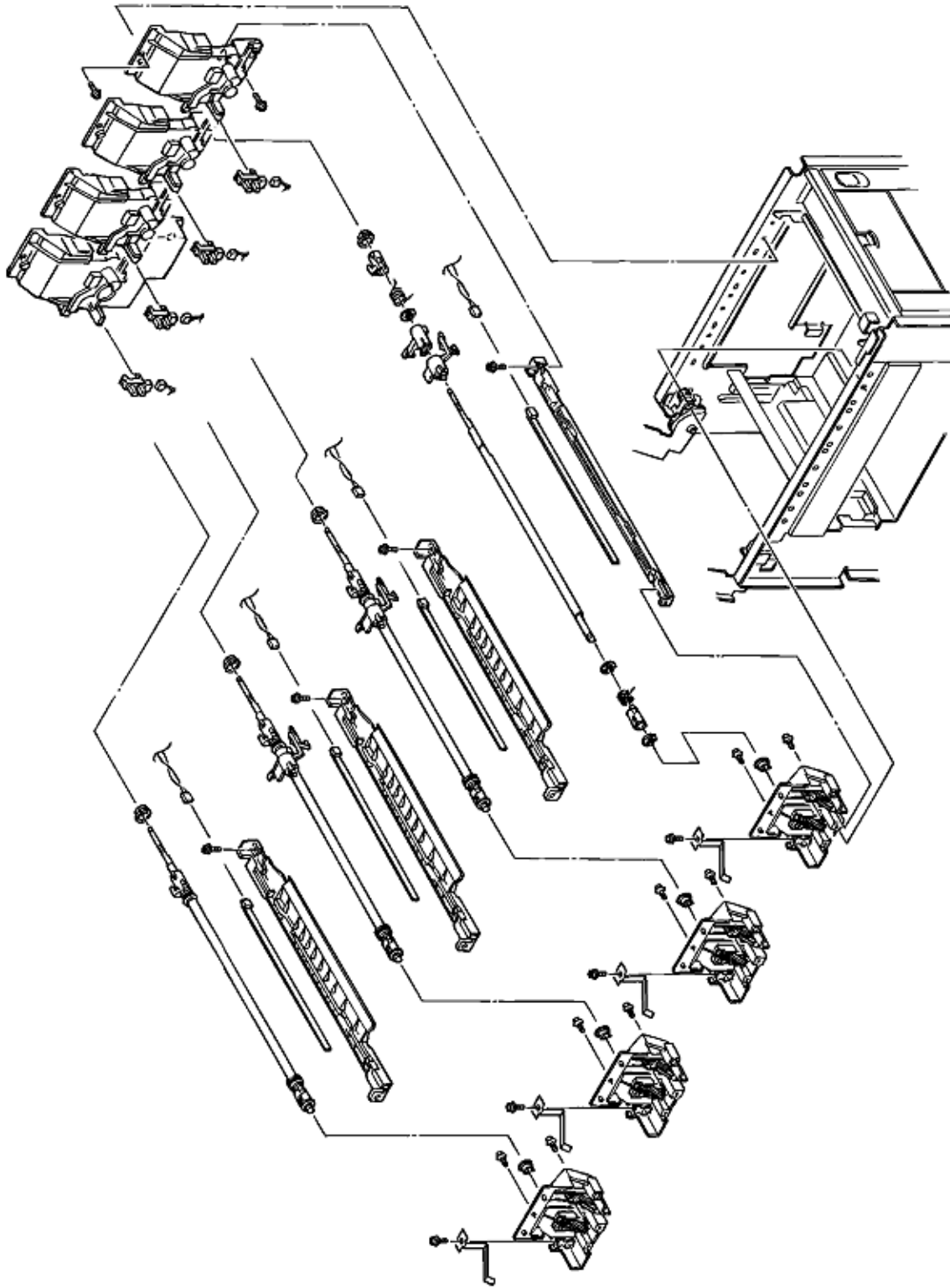


Figure 3-4, Contact Assemblies





---

### **3.3 How to Change Parts**

This section explains how to change parts and assemblies appearing in the disassembly diagram below.

- 3.3.1 Cover Assy Rear
- 3.3.2 Motor Fan (80-25)
- 3.3.3 Paper Eject Assy
- 3.3.4 Cover Assy Stacker Guide Eject FD Assy
- 3.3.5 Frame Assy Upper
- 3.3.6 Plate Support Assy
- 3.3.7 Limiter 2Way (L), (R) / Plate Guide (L), (R)
- 3.3.8 Cover
- 3.3.9 PCB Assy: PCE
- 3.3.10 Motor Fan (CU)
- 3.3.11 PXF PCB/PX4 PCB
- 3.3.12 Gear Heat Assy
- 3.3.13 Main Motor (A), (B) Assy
- 3.3.14 Gear One-way (Z30)
- 3.3.15 Motor Assy BT
- 3.3.16 Power Supply Unit, Holder Inlet, Sheet Insulation
- 3.3.17 Sensor Assy Box Toner
- 3.3.18 Square-shaped Connector
- 3.3.19 Hopping Motor
- 3.3.20 Gear One-Way
- 3.3.21 Feeder Unit Front
- 3.3.22 Manual Feed Hopper Assy
- 3.3.23 Guide Paper Input Assy
- 3.3.24 Lever Input Sensor
- 3.3.25 Roller Registration, Roller Assy Hopping
- 3.3.26 Roller Hopping
- 3.3.27 PXU PCB/PXM PCB, Lever Regist Sensor
- 3.3.28 Paper End Lever
- 3.3.29 PCO PCB (Operator Panel)
- 3.3.30 Holder Gear Toner Assy
- 3.3.31 Plate Latch Lever (FD), Spring Latch Lever (FD)
- 3.3.32 Belt Cassette Assy
- 3.3.33 High Voltage Power Supply Unit, Bracket HV
- 3.3.34 Erase Bracket Assy, Eraser Bracket
- 3.3.35 Shaft Link
- 3.3.36 Contact (BL-R) Assy, Contact (CL-R) Assy
- 3.3.37 Contact (BL-L) Assy, Contact (CL-L) Assy



- 3.3.38 Contact SB Assy
- 3.3.39 PXC PCB
- 3.3.40 Heat Unit Assy
- 3.3.41 Oil Roller Assy
- 3.3.42 Lever Lock Heat (L) / (R), Guide Side Heat, Spring Lock
- 3.3.43 PXL PCB
- 3.3.44 Heat Unit Guide Assy
- 3.3.45 Holder LED Assy, LED Head



### 3.3.1 Cover Assy Rear

Remove the 2 screws (1) then lift the cover assy rear (2) a little bit, then remove the cover assy rear by releasing the two claws.

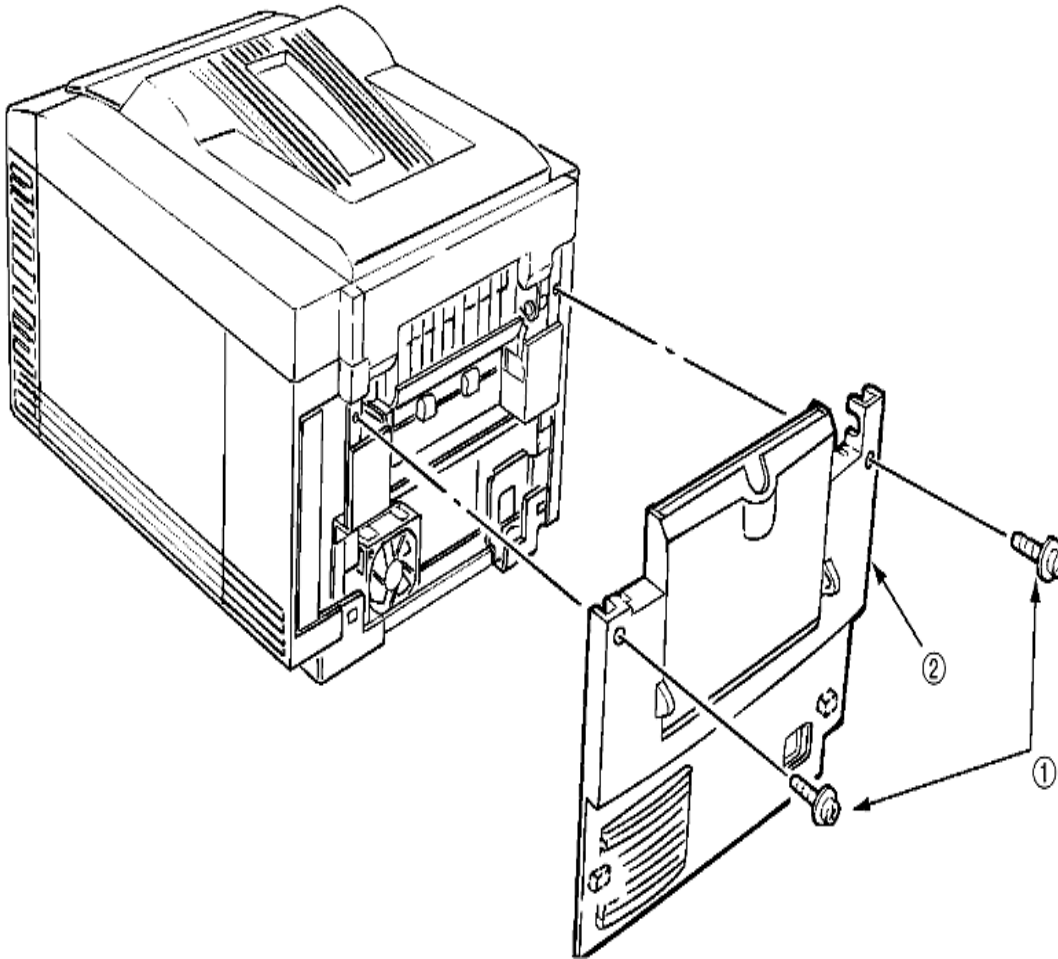


Figure 3.3.1 Cover Assy Rear



### 3.3.2 Motor-Fan (80-25)

1. Remove the cover assy rear (See 3.3.1)
2. Remove the two screws (1).
3. Detach the fan motor (2) from the guide with its right side lifted then draw the fan motor.
4. Detach the cable (3) then remove the fan motor (3).

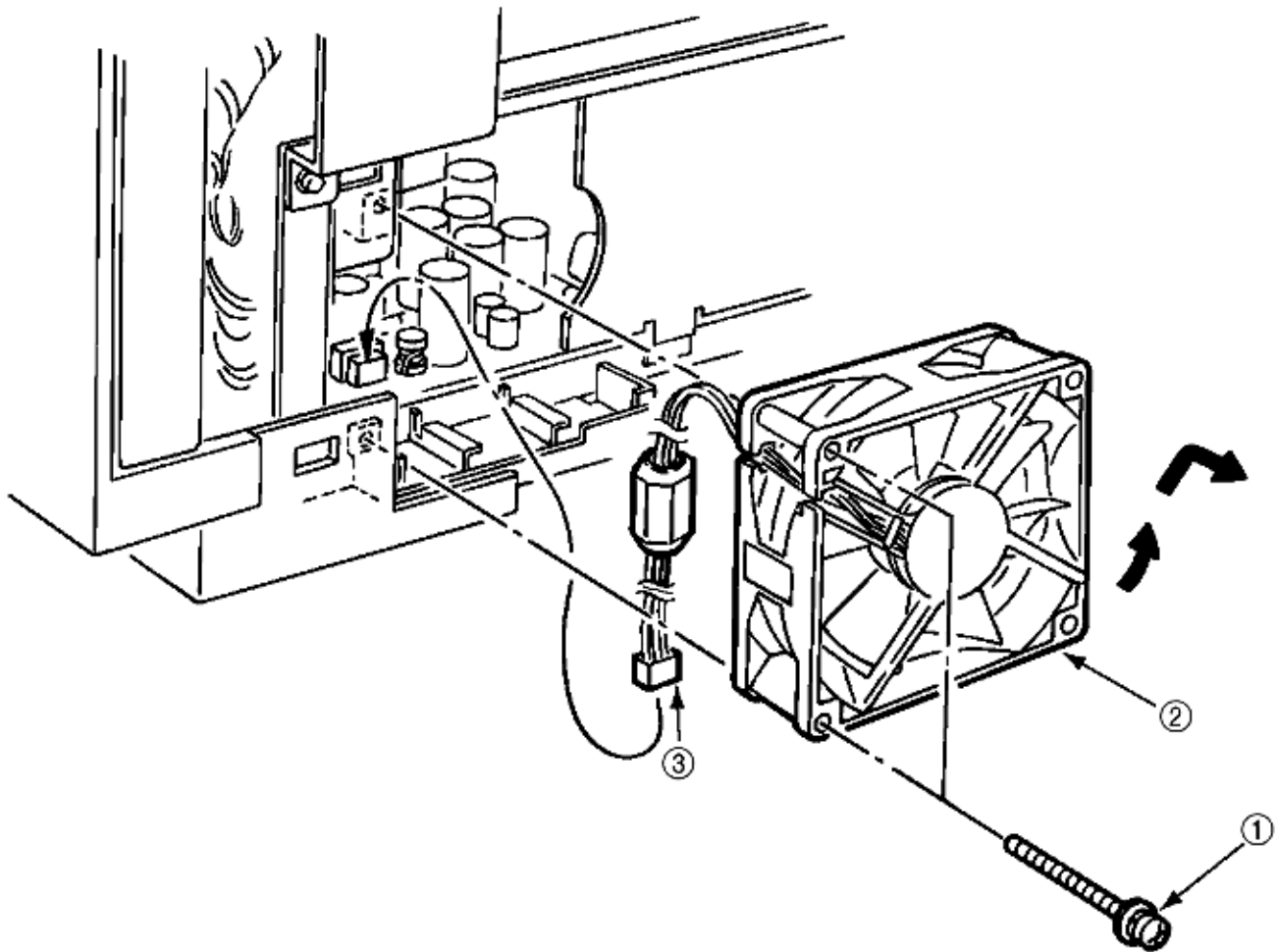


Figure 3.3.2 Fan Motor (80-25)



### 3.3.3 Paper Eject Assy

The paper eject assy includes the frame: eject assy and the guide: paper eject assy.

1. Remove the cover assy rear (See 3.3.1)
2. Open the top cover.
3. Unscrew 4 screws (1) then remove the frame eject assy (2).
4. Remove the guide paper eject assy (3) by releasing the lock of one claw.

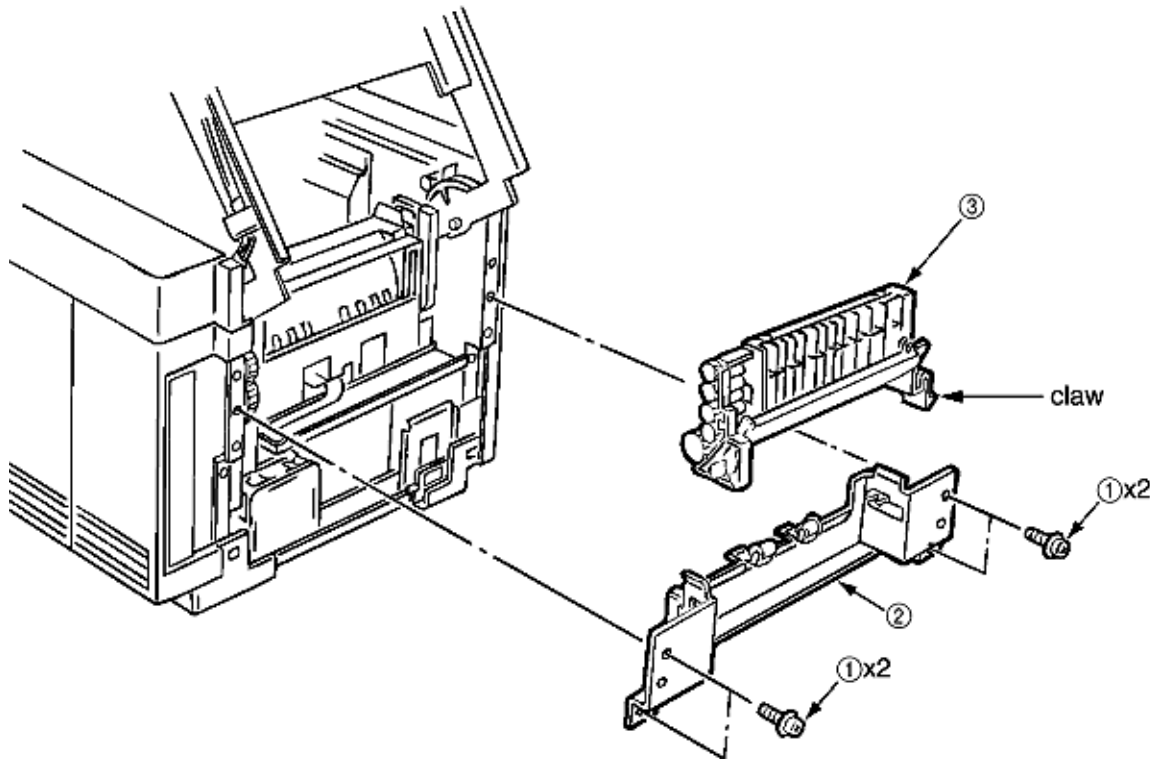


Figure 3.3.3 Paper Eject Assy



### 3.3.4 Cover Assy Stacker, Guide Eject FD Assy

1. Remove the cover assy rear. (See 3.3.1)
2. Release the cable from the cable clamp (1) by opening the clamp.
3. Unscrew 8 screws (2) then remove the cover assy stacker (3).
4. Unscrew 4 screws (4) then remove the guide eject FD assy (5).

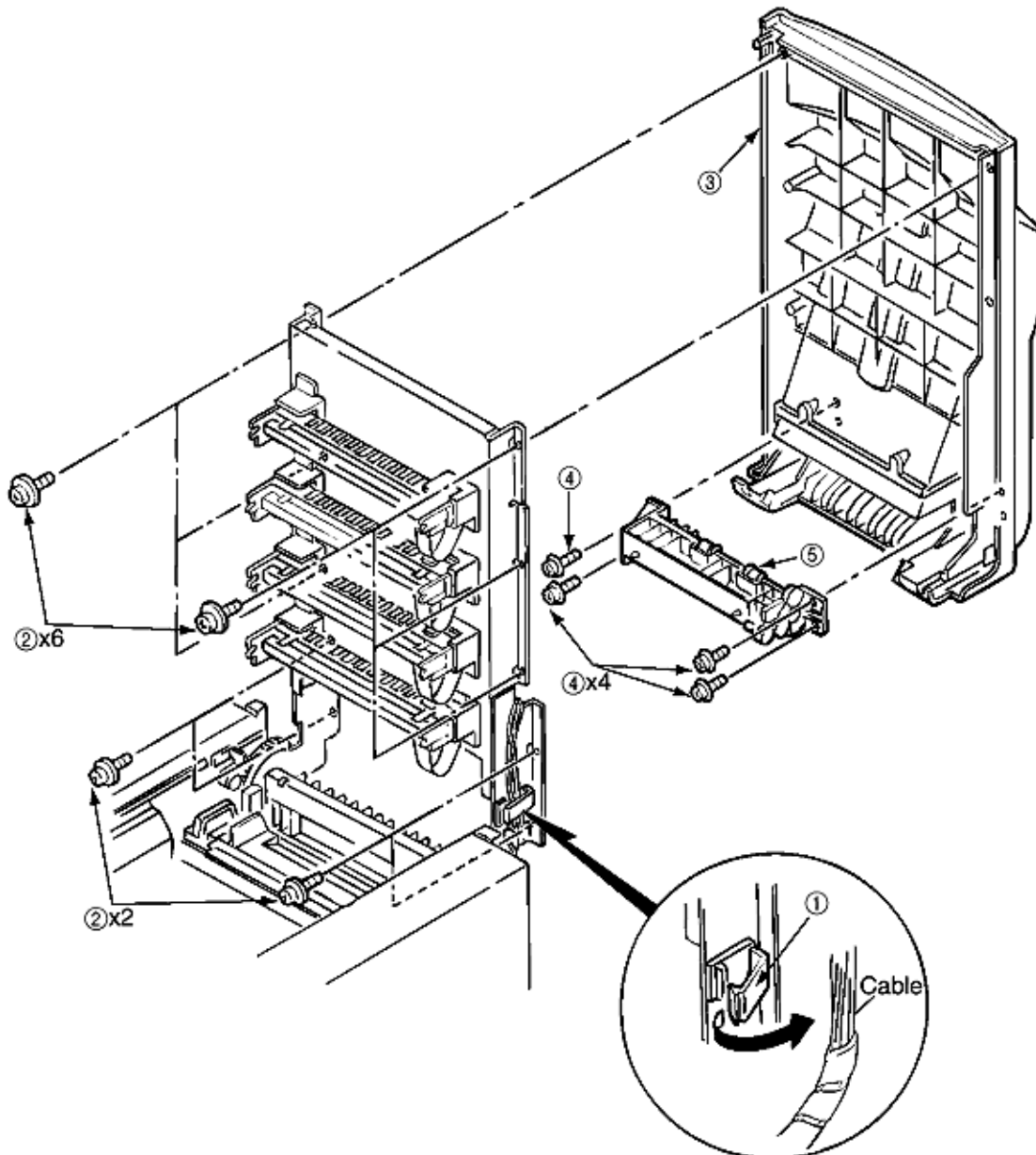


Figure 3.3.4 Cover Assy Stacker, Guide Eject FD Assy





### 3.3.5 Upper Frame Assy

1. Remove the cover assy rear. (See 3.3.1.)
2. Remove the cover assy stacker. (See 3.3.4.)
3. Remove the holder LED assy. (See 3.3.45)
4. Detach the cable from the cable clamp (1) by releasing its lock.
5. Remove connections of 4 connector cables (2) and 4 cables (3).
6. Unscrew 4 screws (4) then remove the PCB (5).
7. Unscrew 2 screw (6) then remove Guide Holder (7) by releasing the clamp of the claw.
8. Unscrew 4 screws (8) then remove the Upper Frame Assy (9).

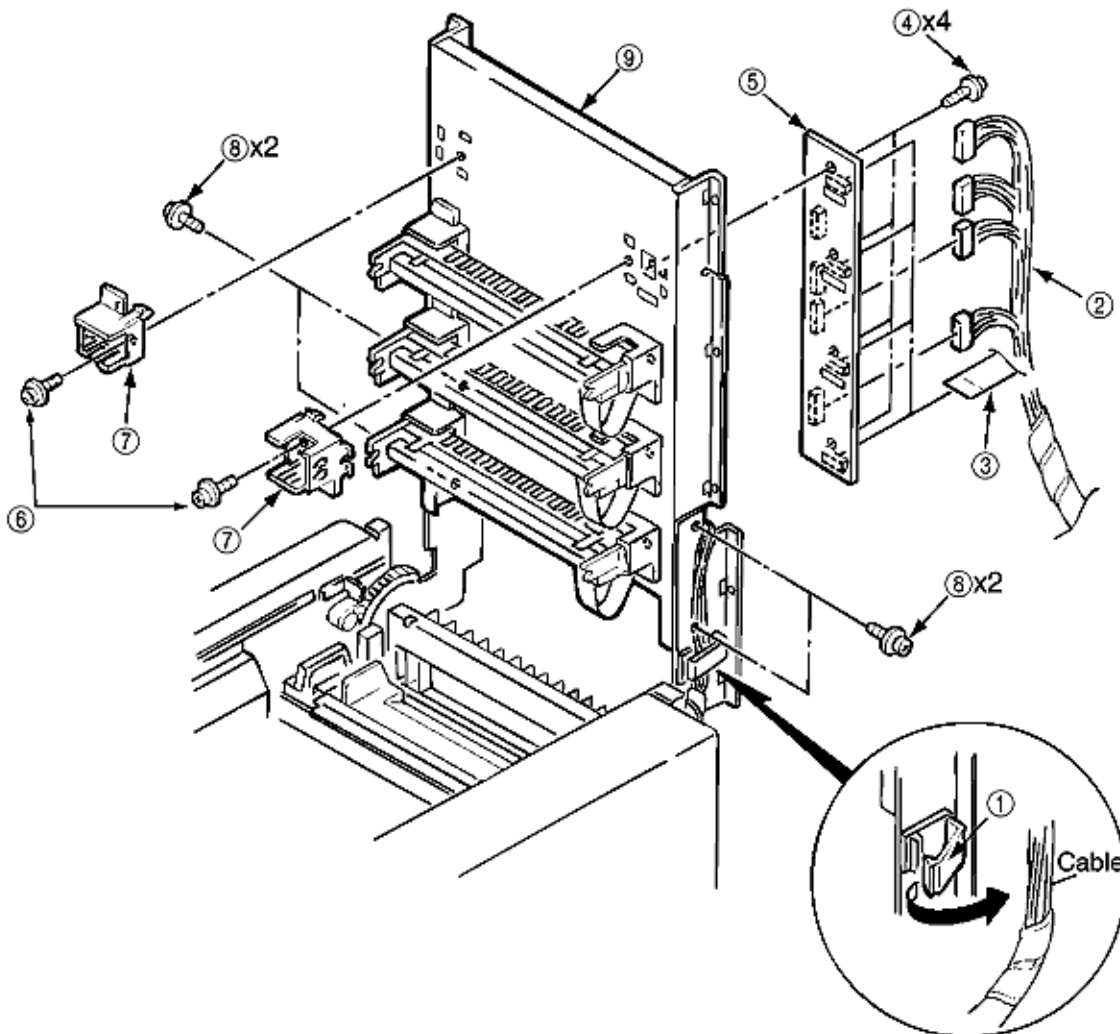


Figure 3.3.5 Upper Frame Assy





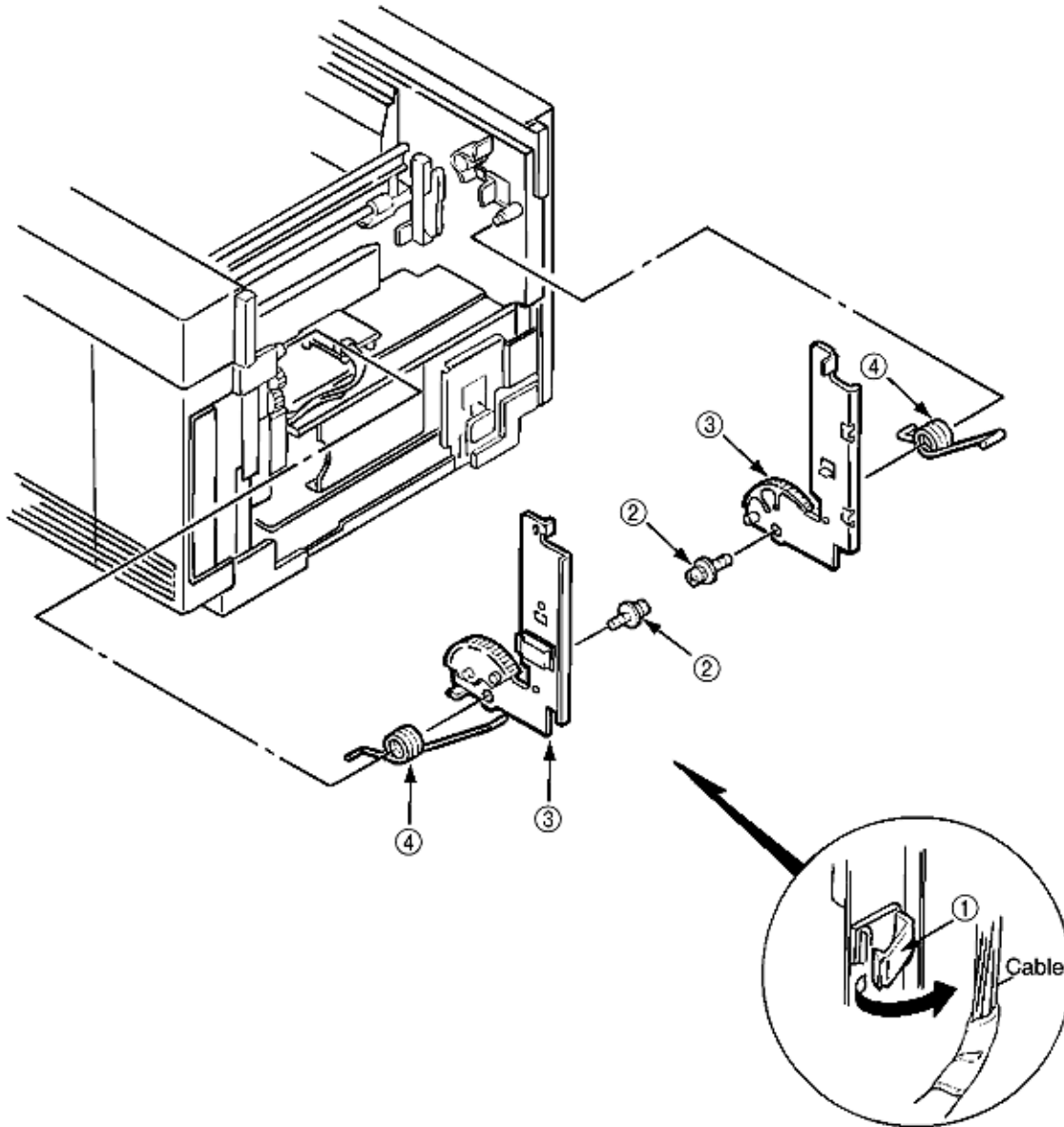


---

### **3.3.6 Plate Support Assemblies**

The plate support assemblies are provided right and left. The method of those replacements is the same.

1. Remove the heat unit assy. (See 3.3.40)
2. Remove the cover assy rear. (See 3.3.1)
3. Remove the cover assy stacker. (See 3.3.4)
4. Remove the frame assy upper. (See 3.3.5)
5. Detach the cable from the flat cable clip (1) by releasing the lock.
6. Remove the 2 screws (2) then remove the plate support assy (3). Be careful not to lose the spring 4 which is removed with the plate support assy (3.)

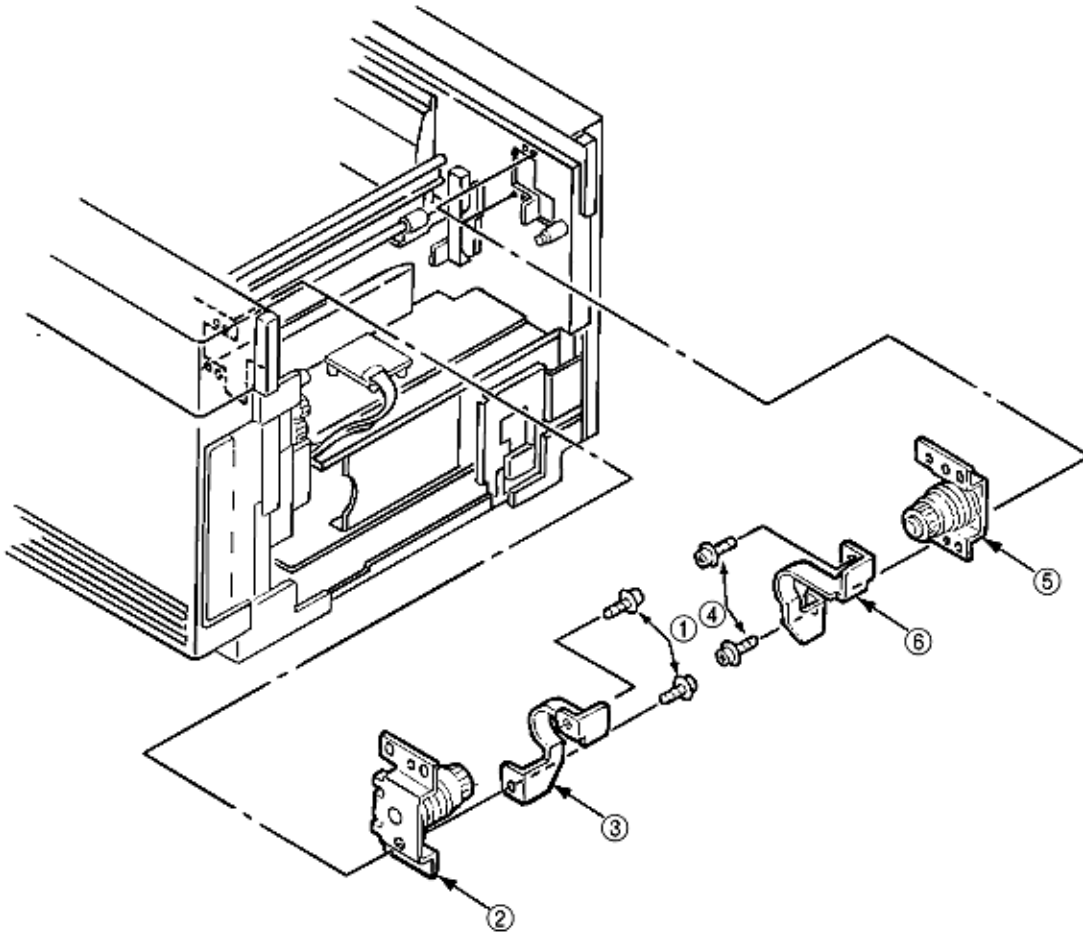


**Figure 3.3.6 Plate Support Assy**



**3.3.7 Limiter 2way (L), (R) / Plate Guide (L), (R)**

1. Remove the plate support assy (L) and (R). (See 3.3.6)
2. Unscrew 2 screws (1) then remove the limiter 2way (L) (2) and the plate guide (L) (3).
3. Unscrew 2 screws (4) then remove limiter 2way (R) (5) and the plate guide (R) (6).



**Figure 3.3.7 Limiter 2way (L), (R) / Plate guide (L), (R)**



---

### **3.3.8 Cover**

Describes the method of removing the cover assy side (L)/(R), cover assy OP panel, cover front (L)/(R) and the cover rear (L).

1. Remove the cover assy rear. (See 3.3.1)
2. Remove the cover assy stacker. (See 3.3.4)
3. Remove the 2 screws (1) then remove the frame side (L) (2).
4. Remove the 2 screws (3) then release the lock of the claw with the cover assy side (R) (4) lifted a little bit, then remove the cover assy side (R).
5. Detach the operator panel cable (5) from the PCM PCB.
6. Open the FDR unit front in the arrow direction.
7. Remove the 2 screws (6) then remove the cover assy OP panel (7).
8. Remove the 2 screws (8), with the cover front (R) (9) pushed up, then release the lock of the claw, then remove the cover front (R).
9. Remove the 2 screws (10) then remove the cover front (L) (11).
10. Remove the 2 screws (12) then remove the cover rear (L) (13).
11. Pull off the film (15) glued on the cassette guide.
12. Release the engagement with the guide by lifting the cover assy side (L) (14), then remove the cover assy side (L).

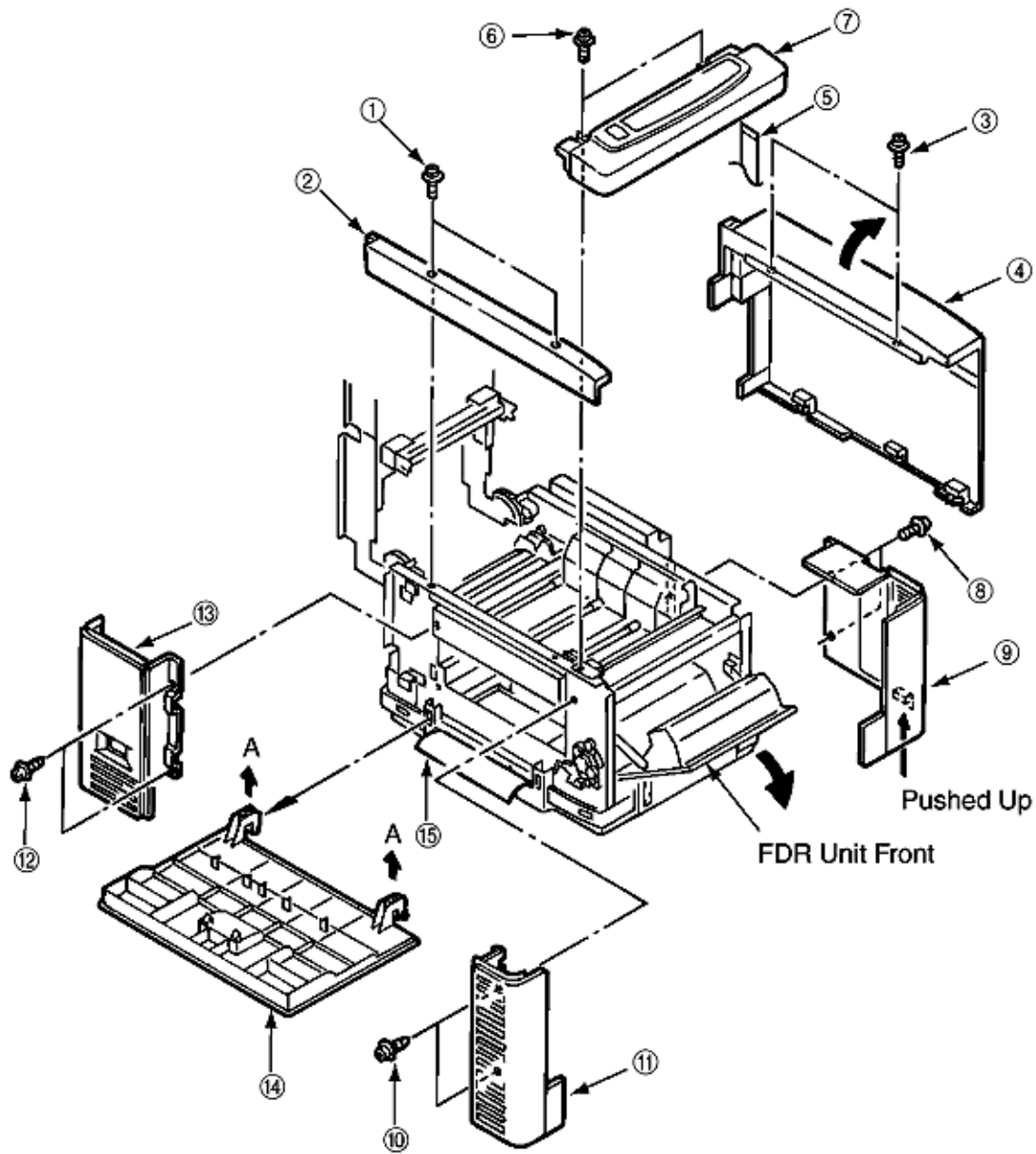


Figure 3.3.8 Cover



### 3.3.9 PCE PCB Assy

1. Open the top cover.
2. Remove the 2 screws (1) and release the lock of the claw by lifting the cover assy side (R) (2) a little bit, then remove the cover assy side (R).
3. Remove the 2 screws (8) to remove the plate shield (CU) (9).
4. Remove the 3 screws (3) to remove the plate sealed (4).
5. Detach the operator panel cable (5) from the PCE PCB. PCE PCB requires ten (10) screws for removal.
6. Remove the 7 screws (6) to remove the PCE PCB (7).

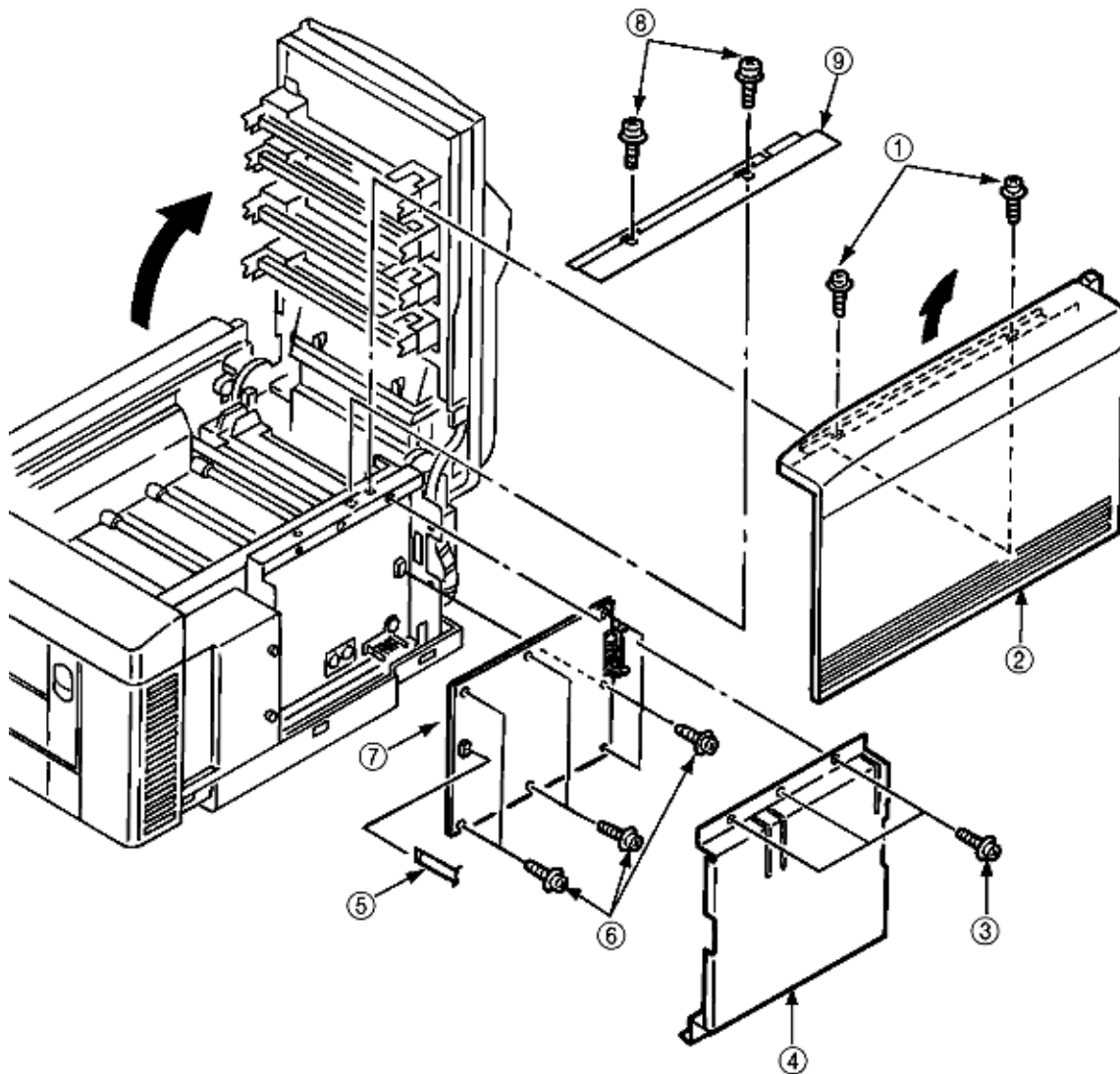


Figure 3.3.9 PCB Assy: PCM





### 3.3.10 Motor Fan (CU)

1. Open the top cover.
2. Remove the cover assy side (R), frame side (L), cover assy OP panel and the cover front (R). (See 3.3.8)
3. Unplug the cable (1) and unscrew 2 screws (2), 2 collars (4) and then remove the motor fan (CU) (3).

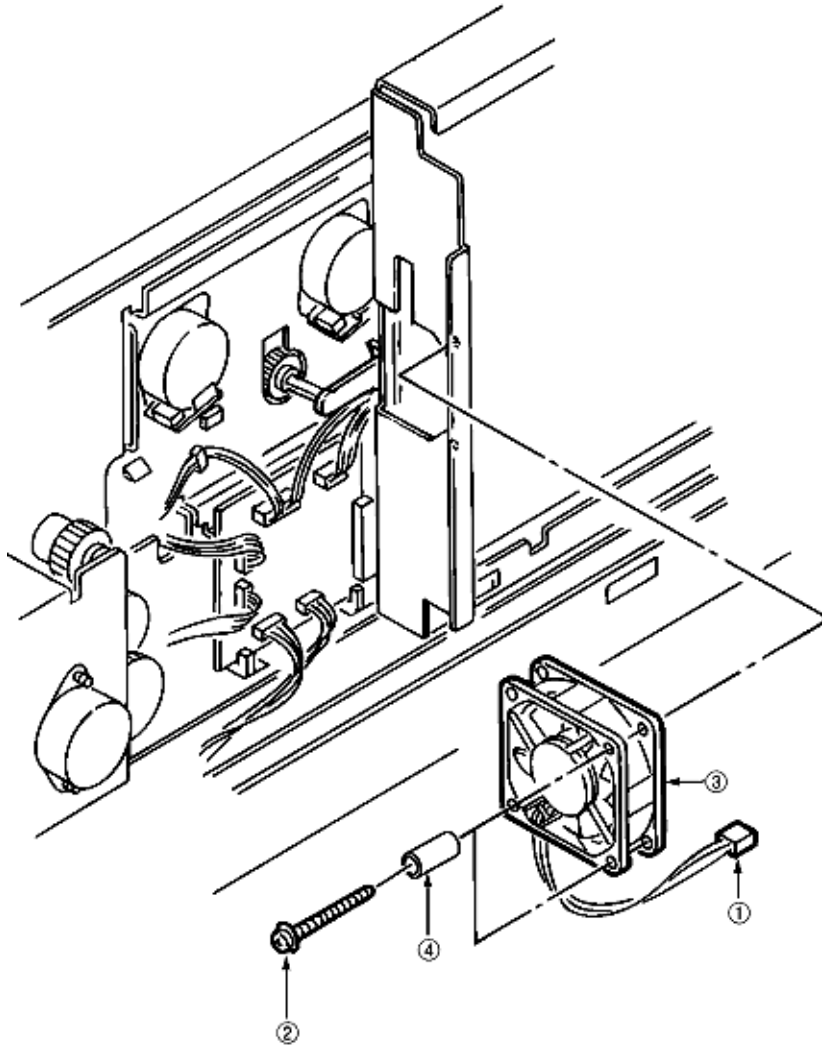


Figure 3.3.10 Motor Fan

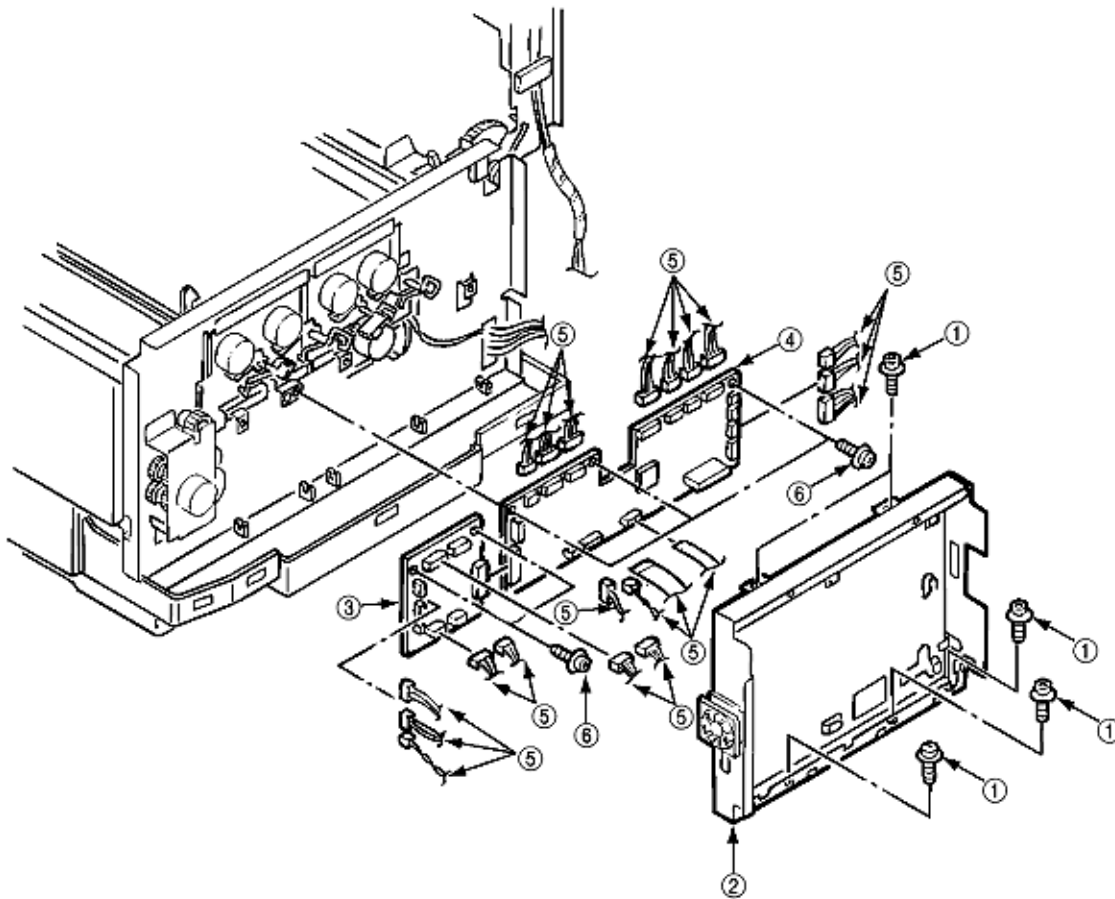




### 3.3.11 PXF PCB / PX4 PCB

Since the PXF PCB and PX4 PCB are connected with each other via the connector, remove them at the same time.

1. Remove the PCB assy : PCM. (See 3.3.9)
2. Unscrew 5 screws (1) then remove the cover CU (2).
3. Unplug all the cables (5) connected to the PXF PCB (3) and PX4 PCB (4).
4. Unscrew 5 screws (6) then remove the PXF PCB (3) and PX4 PCB (4) at the same time.



**Figure 3.3.11 PXF PCB / PX4 PCB**



### 3.3.12 Gear Heat Assy

1. Remove the cover assy side (R), cover assy OP panel, cover front (R) and the cover rear (L). (See 3.3.8)
2. Remove the cover CU then unplug all the cables connected to the PX4 PCB and unscrew 3 screws. (See 3.3.11)
3. Unplug all the cables connected to the PXF PCB then remove the PX4 PCB. (See 3.3.11) **(Be careful not to damage the connector when unplugging cables connected to the PXF PCB.)**
4. Remove the heat unit assy. (See 3.3.40)
5. Remove the guide paper eject assy. (See 3.3.3)
6. Remove the motor fan (80-25). (See 3.3.2)
7. Remove the 5 screws (1) and detach the cable (2) then remove the guide heat assy (3).
8. Remove the 2 screws (4) then remove the motor (ID) (5).

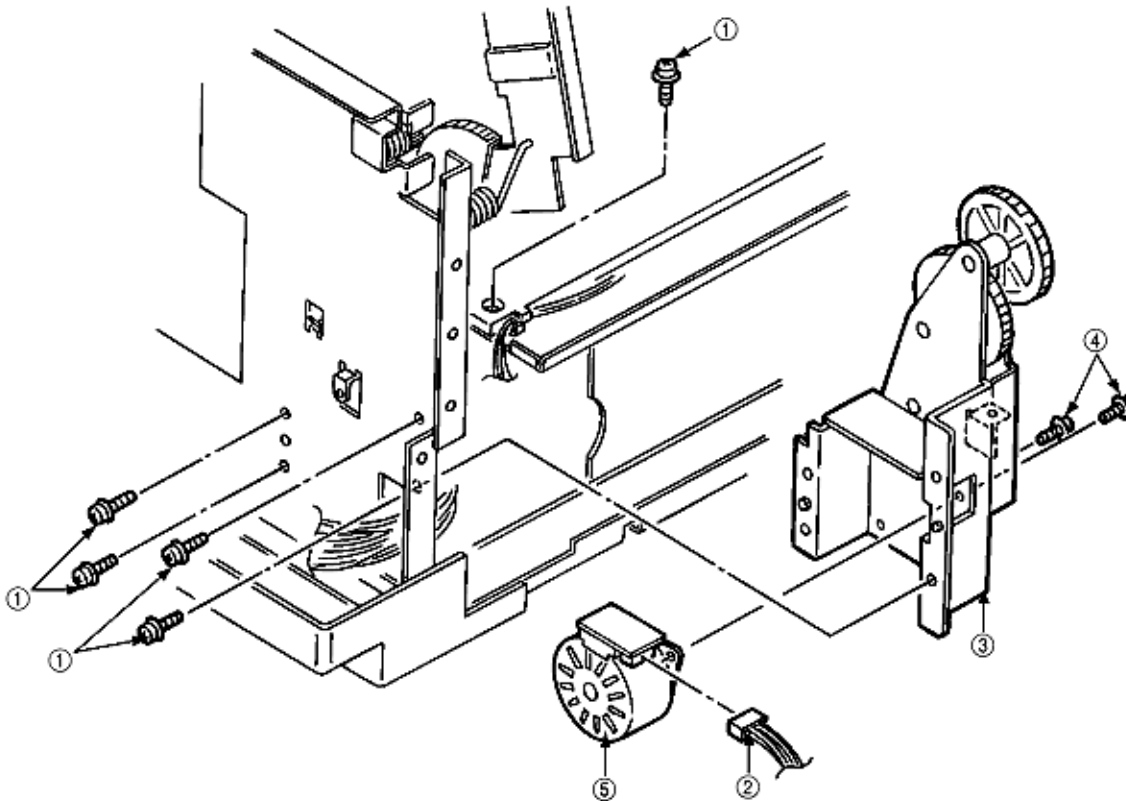
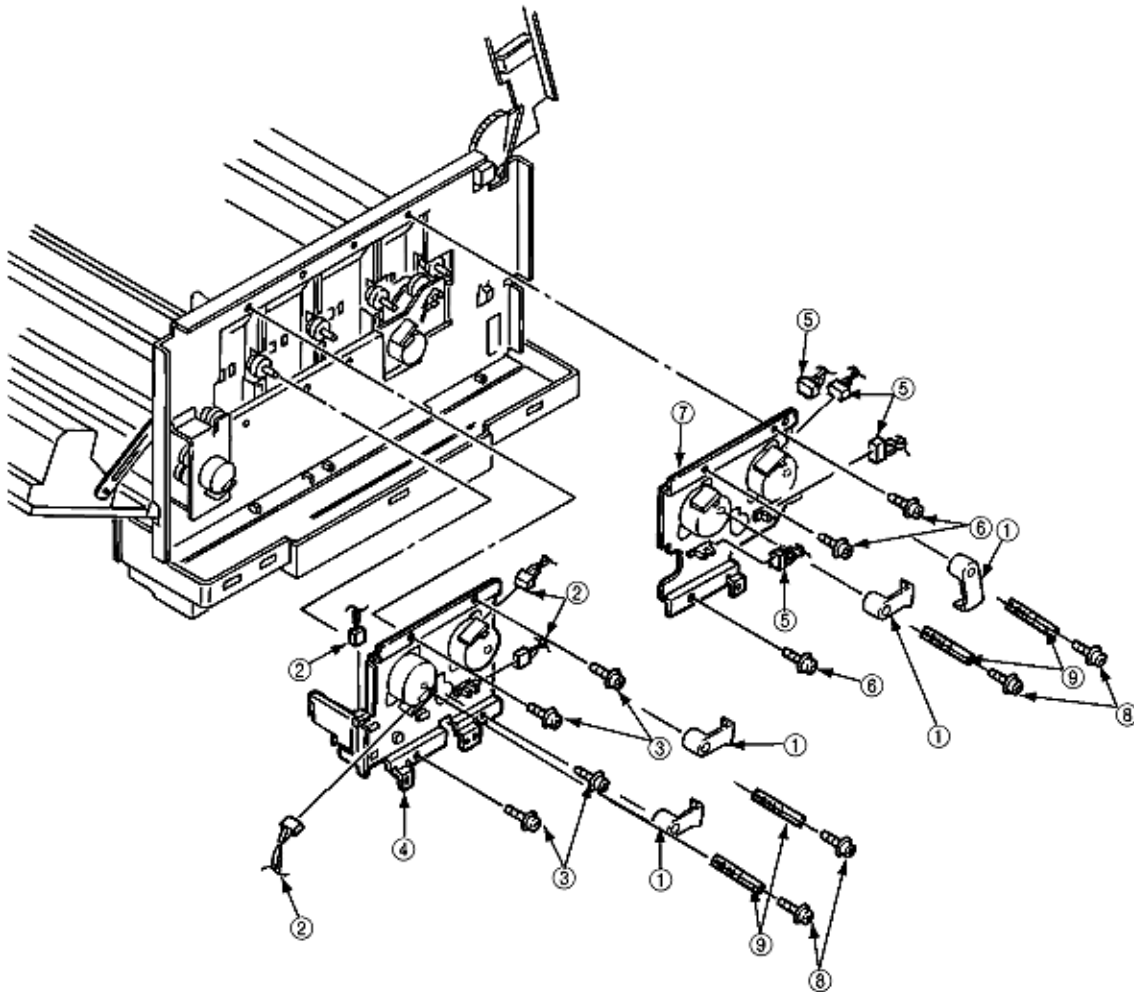


Figure 3.3.12 Gear Heat Assy



**3.3.13 Main Motor (A), (B) Assy**

1. Remove the PXF PCB and PX4 PCB. (See 3.3.11)
2. Remove the 4 screws (8) and remove 4 plate-Earth (9) and 4 lever Up/Dn 2 (1).
3. Detach the all the cables (2) connected and unscrew 4 screws (3), then remove the main motor (A) Assy (4).
4. Detach the all the cables (5) connected and unscrew 3 screws (6), then remove the main motor (B) Assy (7).



**Figure 3.3.13 Main Motor (A), (B) Assy**



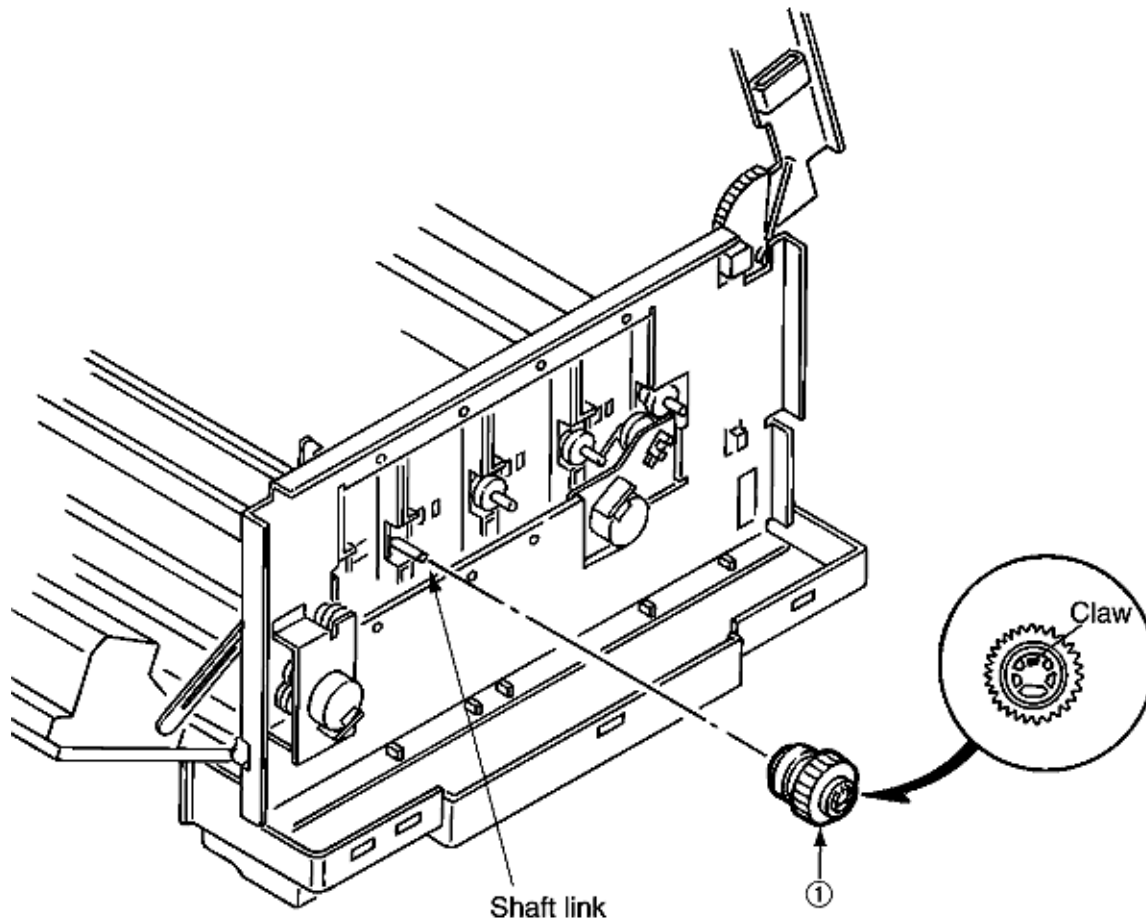
### 3.3.14 Gear One-way (Z30)

Four gear one-ways (Z30) are provided but the method of those replacements is the same. Do not disassemble the gear one-ways (Z30) because they are assemblies which require adjustment.

1. Remove the PCB assy : PCM. (See 3.3.9)
2. Remove the cover CU. (See 3.3.11)
3. Remove the 4 Plate-Earth and 4 lever Up/Dn 2. (See 3.3.13)
4. Release the lock with the shaft by spreading the claw, then remove the gear one-way (Z30) (1).

[Notice for mounting]

Mount the gear one-way (Z30) by fitting it with the shaft link turned in the arrow direction.



**Figure 3.3.14 Gear One-Way (Z30)**



### 3.3.15 Motor Assy Belt

1. Remove the main motor (B) assy. See (3.3.13)
2. Unplug 2 cables (1) connected and unscrew 2 screws (2), then remove the motor assy belt (3).

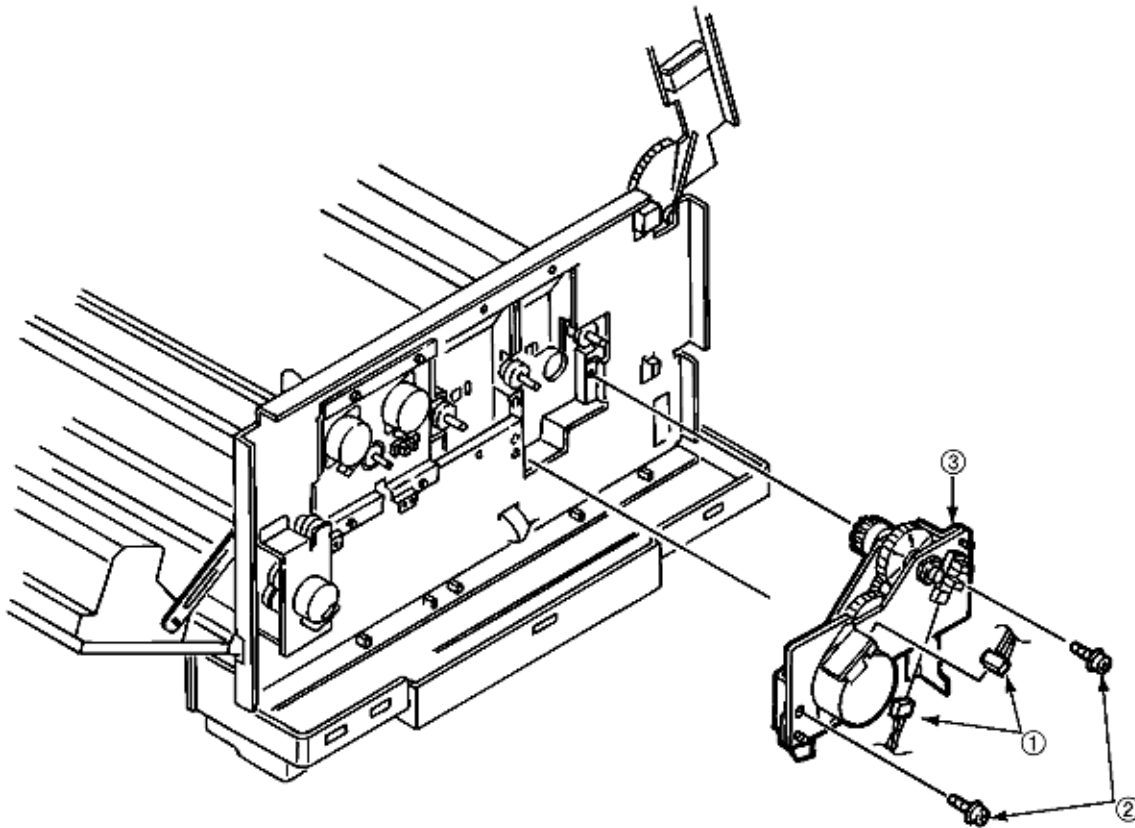


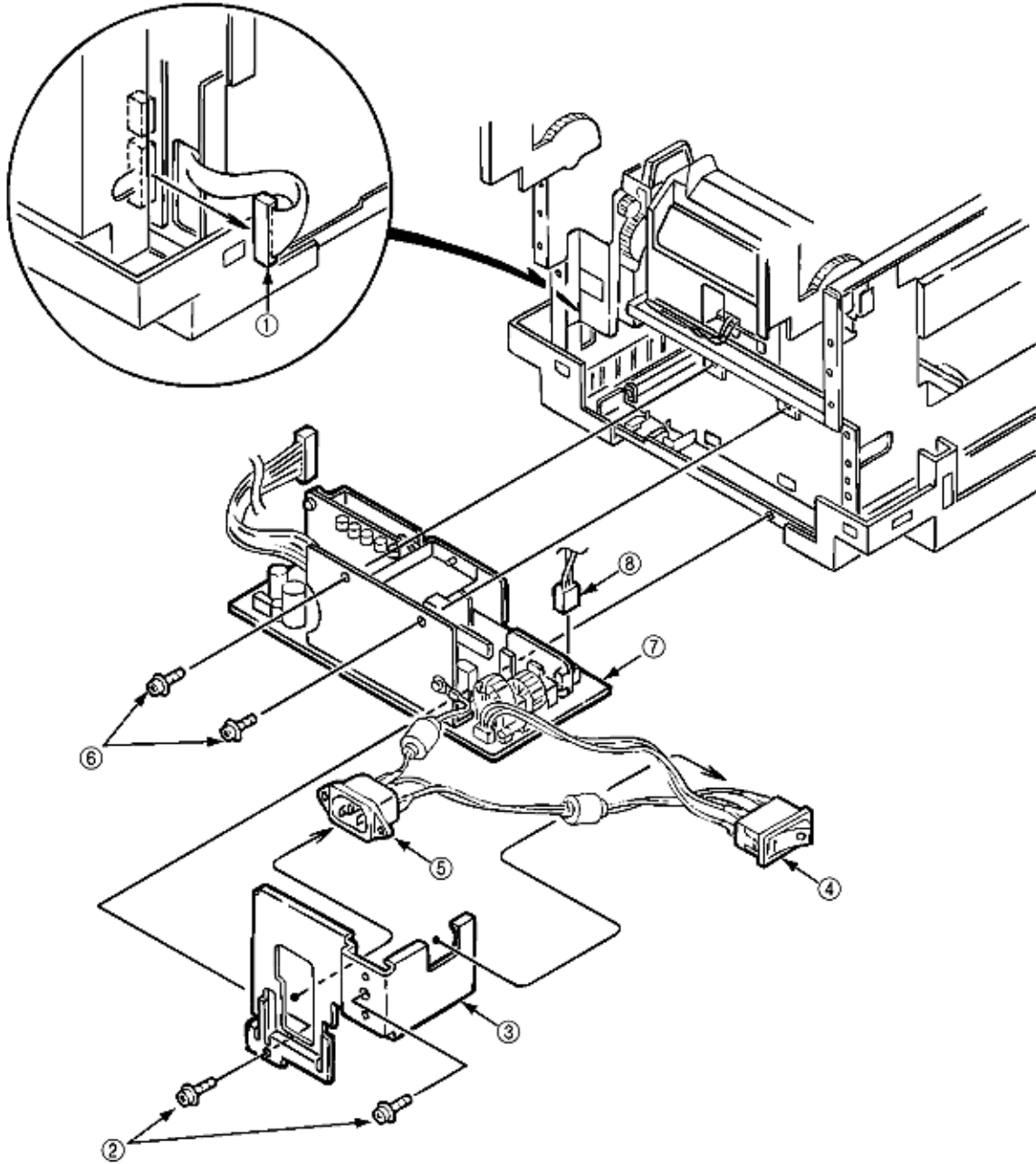
Figure 3.3.15 Motor Assy Belt



---

### **3.3.16 Power Supply Unit, Holder Inlet, Sheet Insulation**

1. Remove the motor-fan (80-25). (See 3.3.2)
2. Remove the frame side (L), the cover assy side (R) and the cover rear (L). (See 3.3.8)
3. Unplug the cable (1).
4. Remove the holder inlet (3) by unscrewing 2 screws (2), then remove the power switch (4) and unplug the AC socket (5).
5. Draw the power supply unit (7) by unscrewing 2 screws (6), then unplug the cable (8).



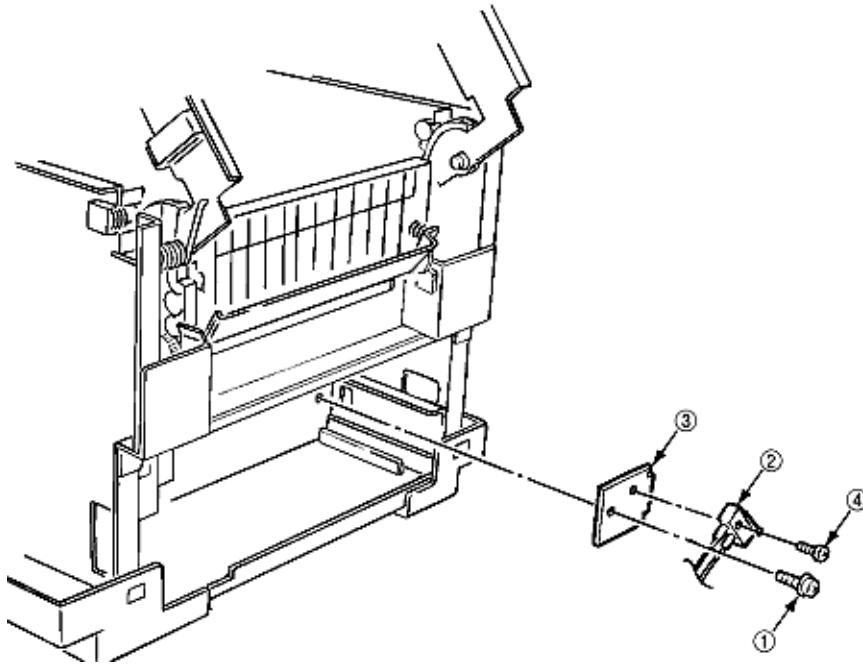
**Figure 3.3.16 Power Supply Unit, Holder Inlet, Sheet Insulation**



---

### 3.3.17 Sensor Assy Box Toner

1. Remove the power supply unit. (See 3.3.16)
2. Unscrew the screw (1) then remove the sensor assy box toner (2) together with the bracket (3).
3. Unscrew the screw (4) then remove the sensor assy box toner (2).



**Figure 3.3.17 Sensor Assy Box Toner**





---

### **3.3.18 Square-shaped Connector**

1. Remove the power supply unit. (See 3.3.16) (Do not remove the power switch and AC socket from the holder inlet.)
2. Unplug the cable (1).
3. Remove cable (2), screw (5) and bracket (6) and cable (7) in order and then take off SW from bracket (6) to pull off square-shaped connector (4).

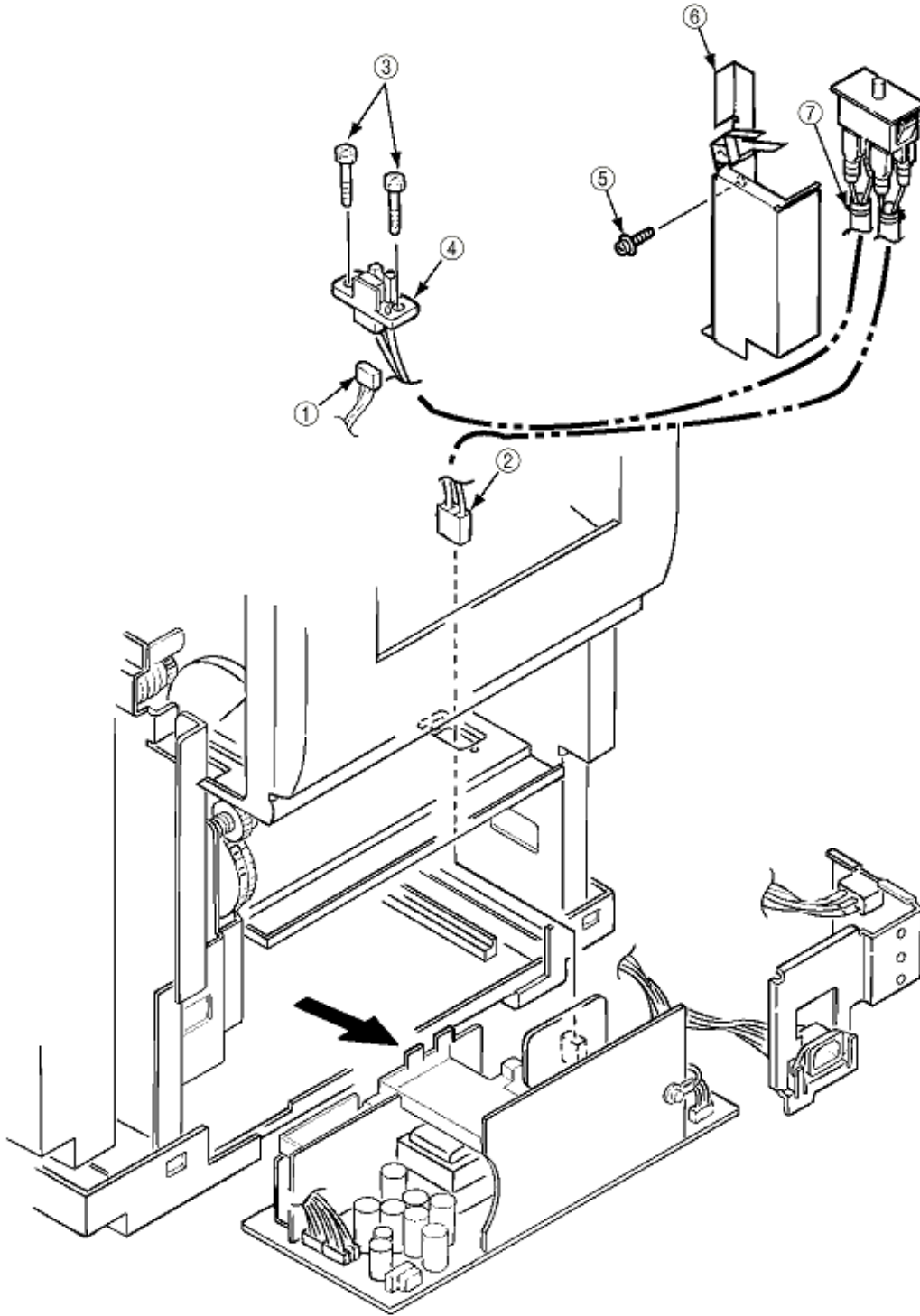


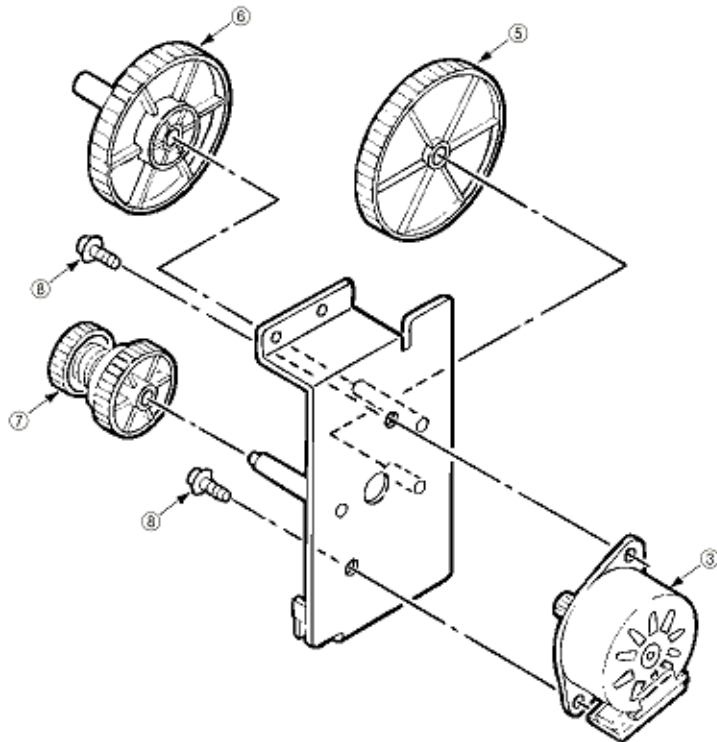
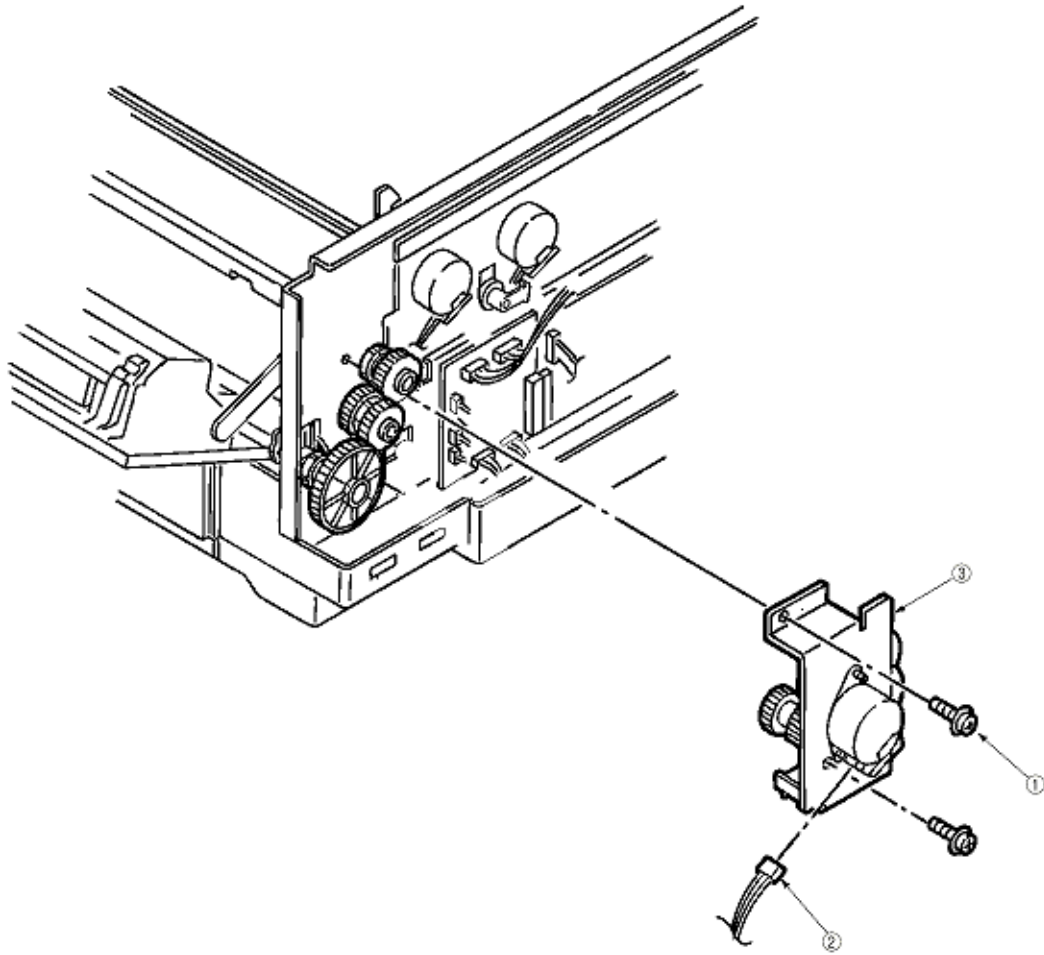
Figure 3.3.18 Square-shaped Connector



---

**3.3.19 Motor - Pulse (ID)**

1. Remove the cover assy side (R), cover assy OP panel and the cover front (R). (See 3.3.8)
2. Unscrew 2 screws (1) and unplug the cable (2), then remove the bracket hopping motor (3). (Be careful not to lose the gears (5), (6) and (7) which slip off at this time.)
3. Unscrew 2 screws (8) then remove the hopping motor (3).



**Figure 3.3.19 Motor - Pulse (ID)**

---

Copyright 1999, Okidata, Division of OKI America, Inc. All rights reserved.



### 3.3.20 One-way Gears

1. Remove the bracket hopping motor. (See 3.3.19).
2. Remove the spacer (4) first and release the locks with the shaft by spreading the claws of the gear one-way (1), (2) and (3), then remove the gear one-ways.

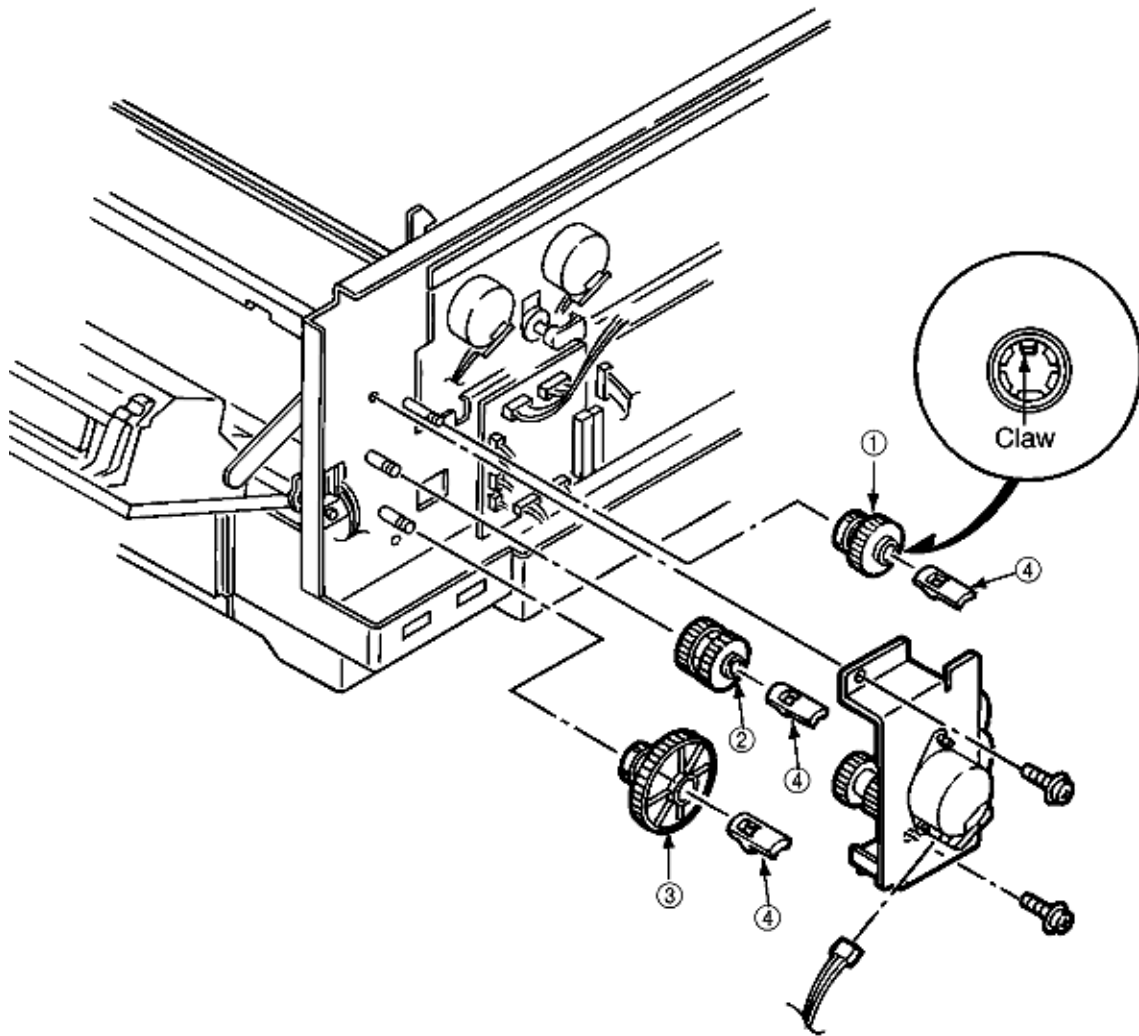
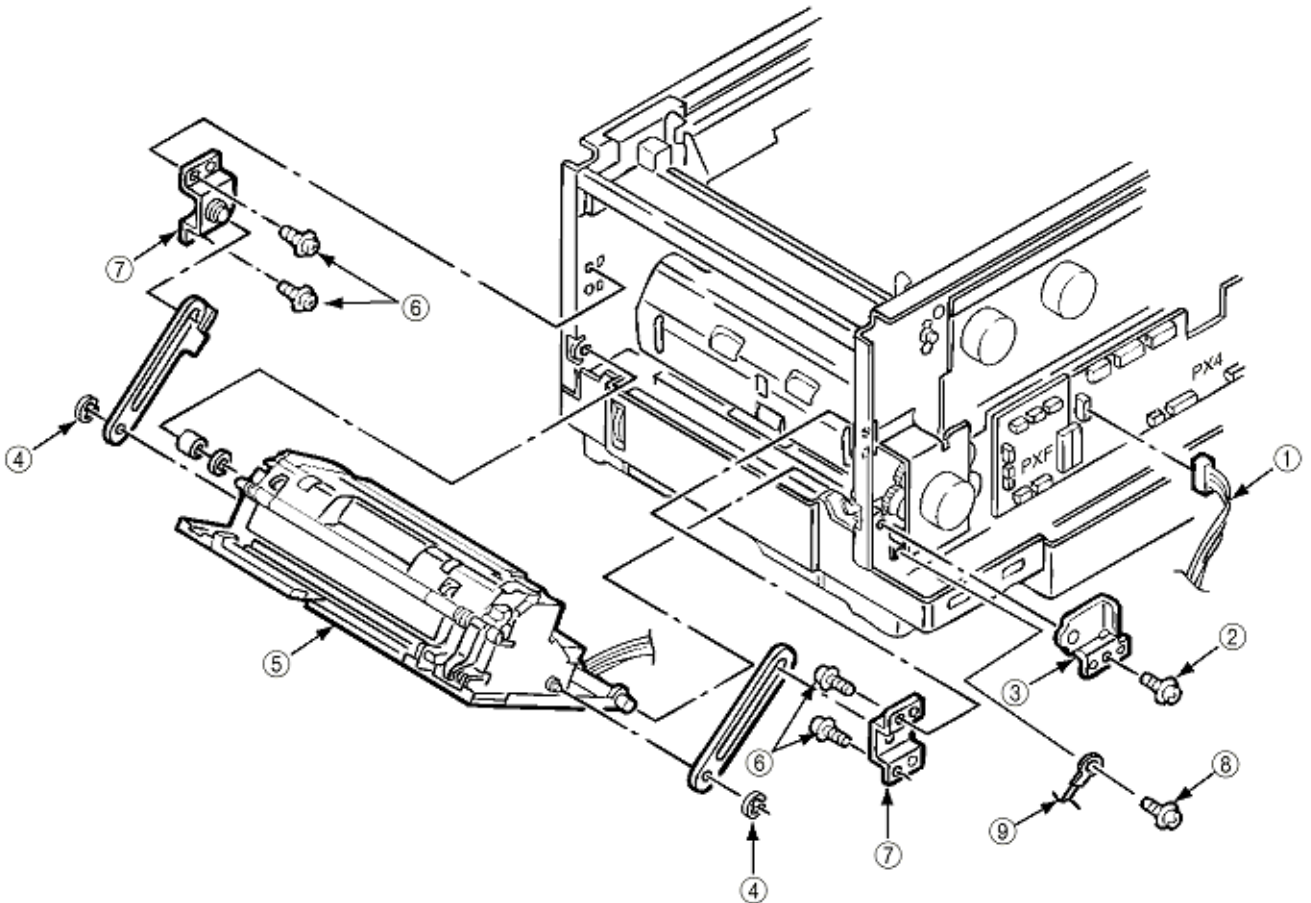


Figure 3.3.20 Gear One-way



### 3.3.21 Feeder Unit Front

1. Remove the cover assy side (R), cover assy OP panel, cover front (R) and the cover front (L). (See 3.3.8.)
2. Remove the cover CU. (See 3.3.11)
3. Unscrw the screw (8) and remove the cable (9).
4. Unplug the cable (1) and unscrew the screw (2), then remove the bracket FF shaft (3).
5. Remove 2 E-rings (4) then remove the feeder unit front (5).
6. Unscrew each 2 screws (6) then remove 2 bracket FF links (7).

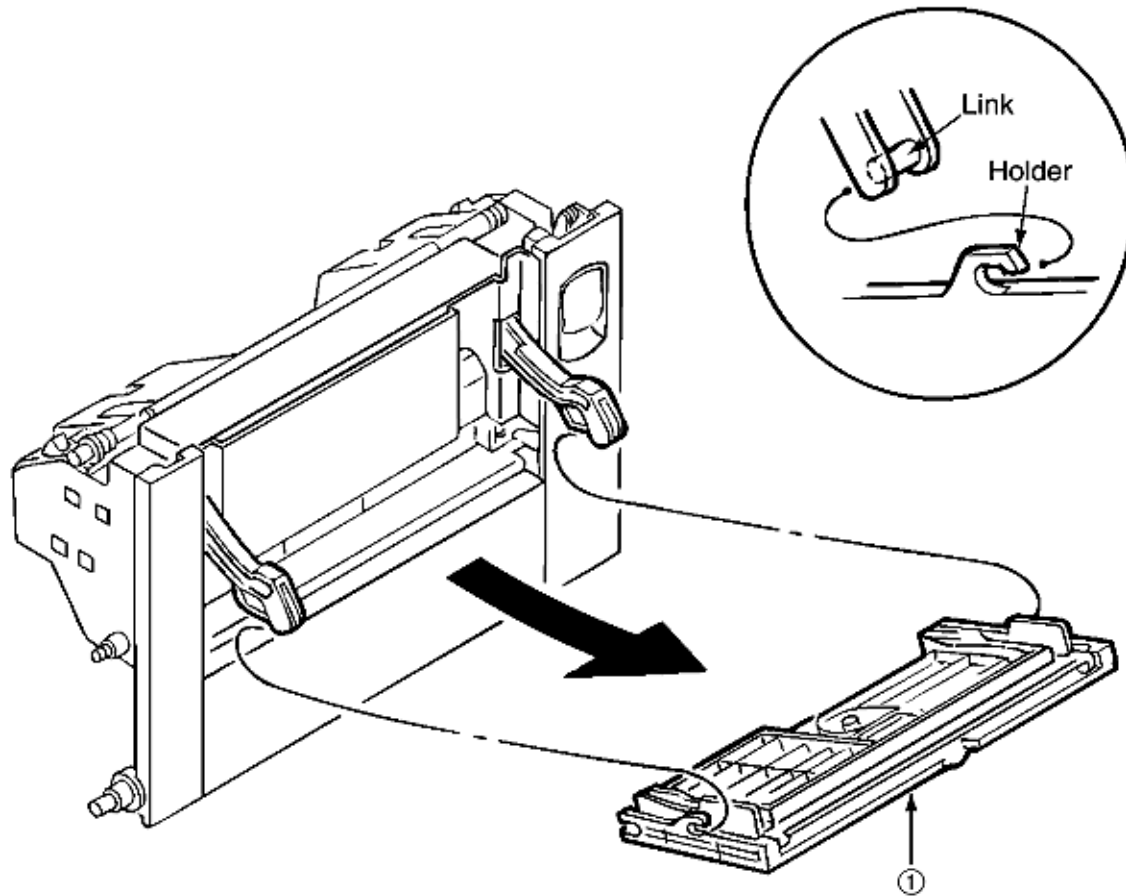


**Figure 3.3.21 Feeder Unit Front**



### 3.3.22 Manual Feed Hopper Assy

1. Open the manual feed hopper assy.
2. Release the engagement between the holder and the link then remove the manual feed hopper assy. (**Be careful not to damage the holder.**)



**Figure 3.3.22 Manual Feed Hopper Assy**

Copyright 1999, Okidata, Division of OKI America, Inc. All rights reserved.





### 3.3.23 Guide Paper Input Assy

1. Remove the cover assy OP panel, cover front (R) and the cover front (L). (See 3.3.8.)
2. Remove the feeder unit front. (See 3.3.21)
3. Unscrew 4 screws (1) then draw out the guide paper input assy (2) from the left side by rotating its upper part. **(Be careful not to damage the lever sensor resist).**

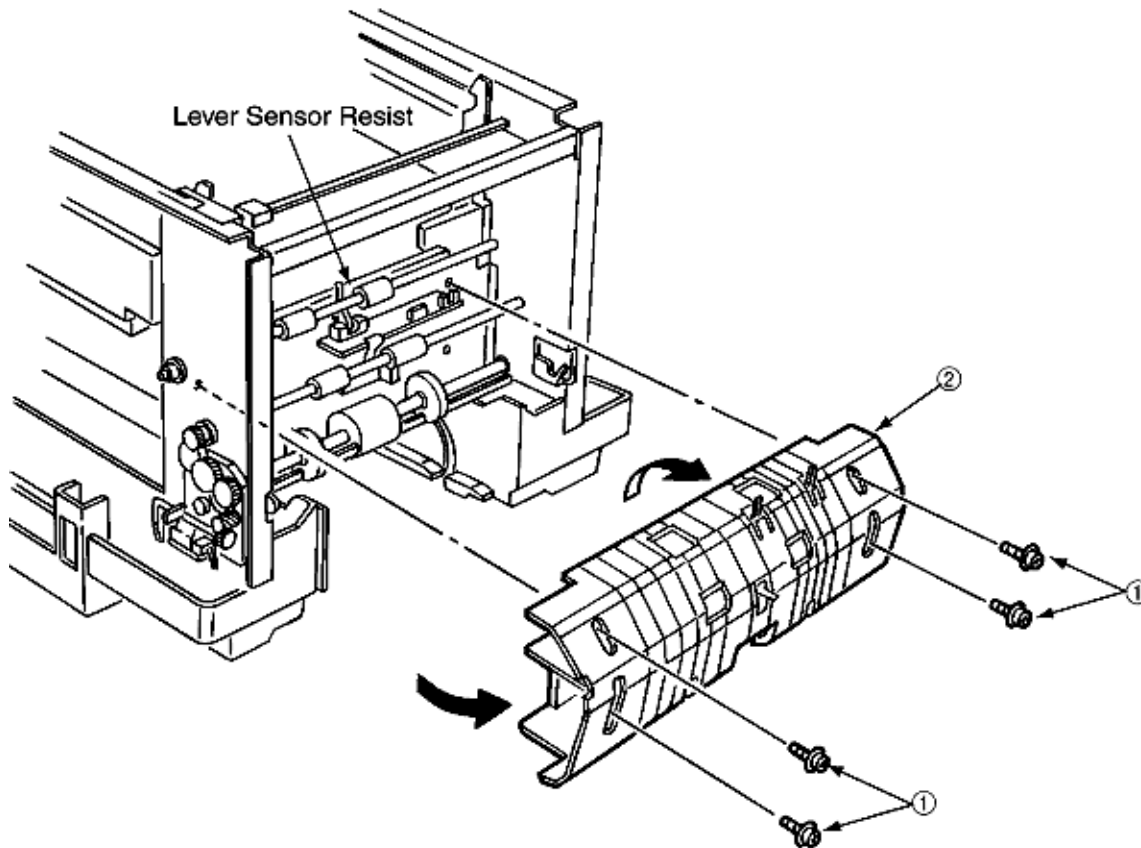


Figure 3.3.23 Guide Paper Input Assy



### 3.3.24 Two Lever Input Sensors, Lever 2nd Feed Sensor

1. Remove the guide paper input assy. (See 3.3.23.)
2. Release the engagement with the guide by pressing the lever 2 input sensors (2) in the arrow direction, then remove them.
3. Release the engagement with the guide by pressing the lever 2nd feed sensor (2) in the arrow direction, then remove the sensor.

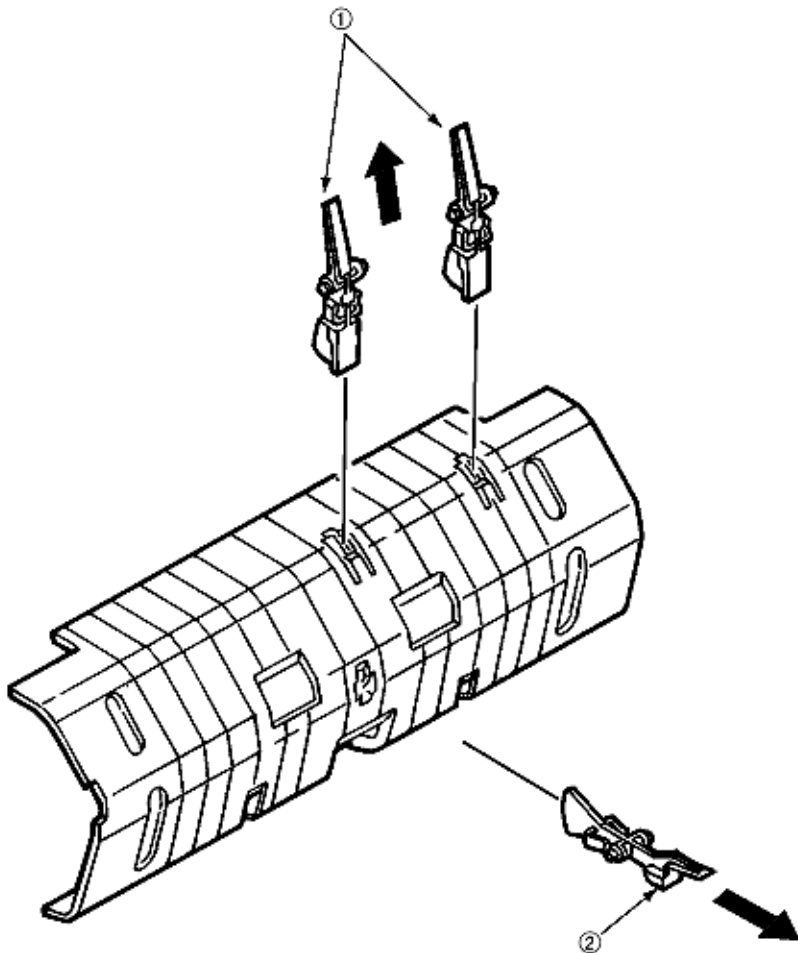


Figure 3.3.24 Two Lever Input Sensors, Lever 2nd Feed Sensor



### 3.3.25 Roller Registration, Roller Assy Hopping

1. Remove the guide paper input assy. (See 3.3.23.)
2. Remove the bracket hopping motor. (See 3.3.19)
3. Remove the gear one-way. (See 3.3.20)
4. Remove the holder gear toner assy. (See 3.3.30)

#### [Removal of the roller registration]

5. Remove the gear (1) and 2 bushes (2) and 2 bearings (3), then 2 roller registrations (4).

#### [Removal of the roller assy hopping]

6. Remove the bush (5) and the bearing (6).
7. Remove E-rings (9) of the sub-roller hopping at both sides of hopping roller and then release the lock of the roller hopping (7) with the shaft (8) by spreading the claw, then remove the roller hopping from the left side by the sliding shaft (8) in the arrow direction. **(Be careful not to lose the knock-pin for fastening the roller hopping (7), which slips off together.)**

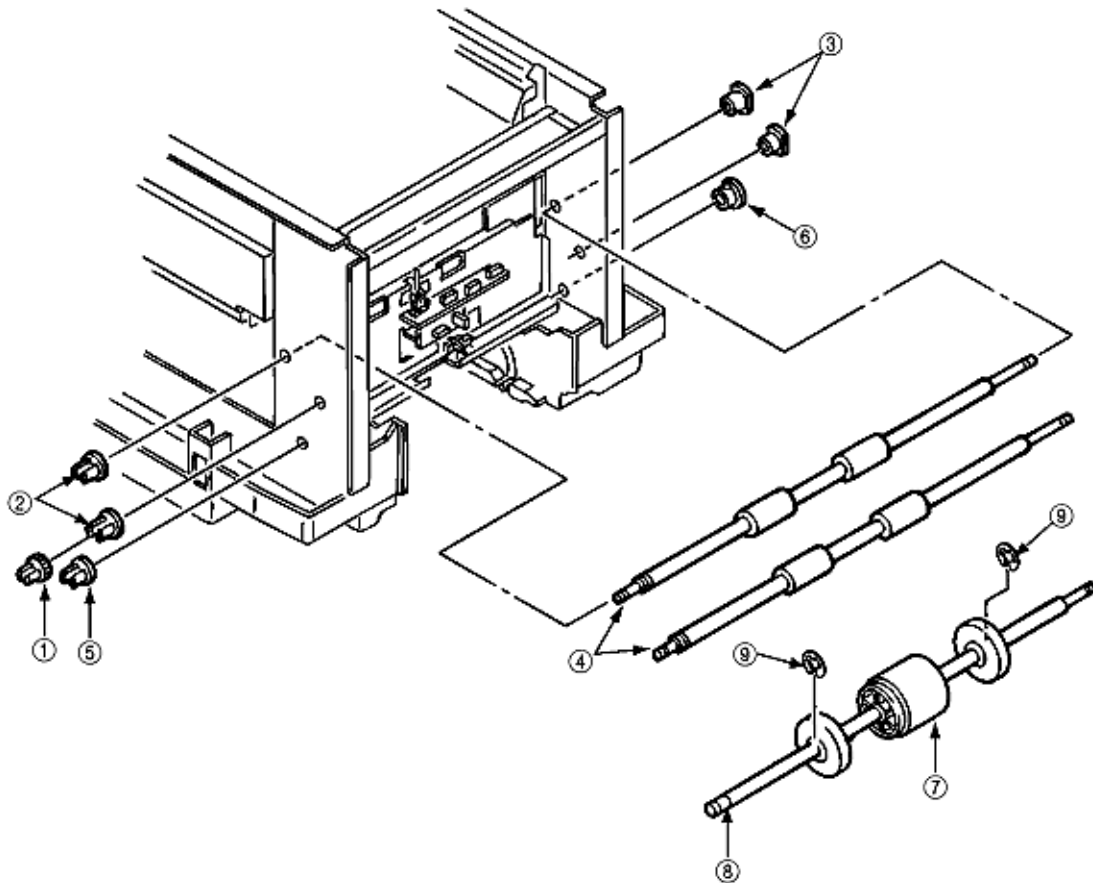


Figure 3.3.25 Roller Registration, Roller Assy Hopping





### 3.3.26 Hopping Roller Assy

1. Remove the roller assy hopping. (See 3.3.25) and remove the 2 sub-roller hopping guide (3). (Be careful not to lose the knock-pin which clips off together when removing the roller assy hopping.)
2. Detach the roller hopping (2) from the shaft (1).

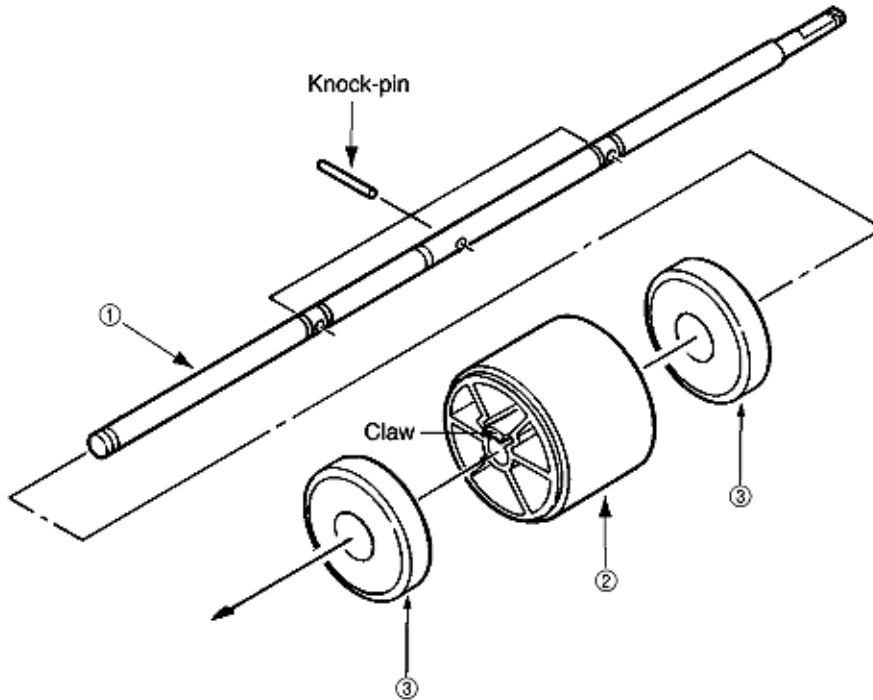


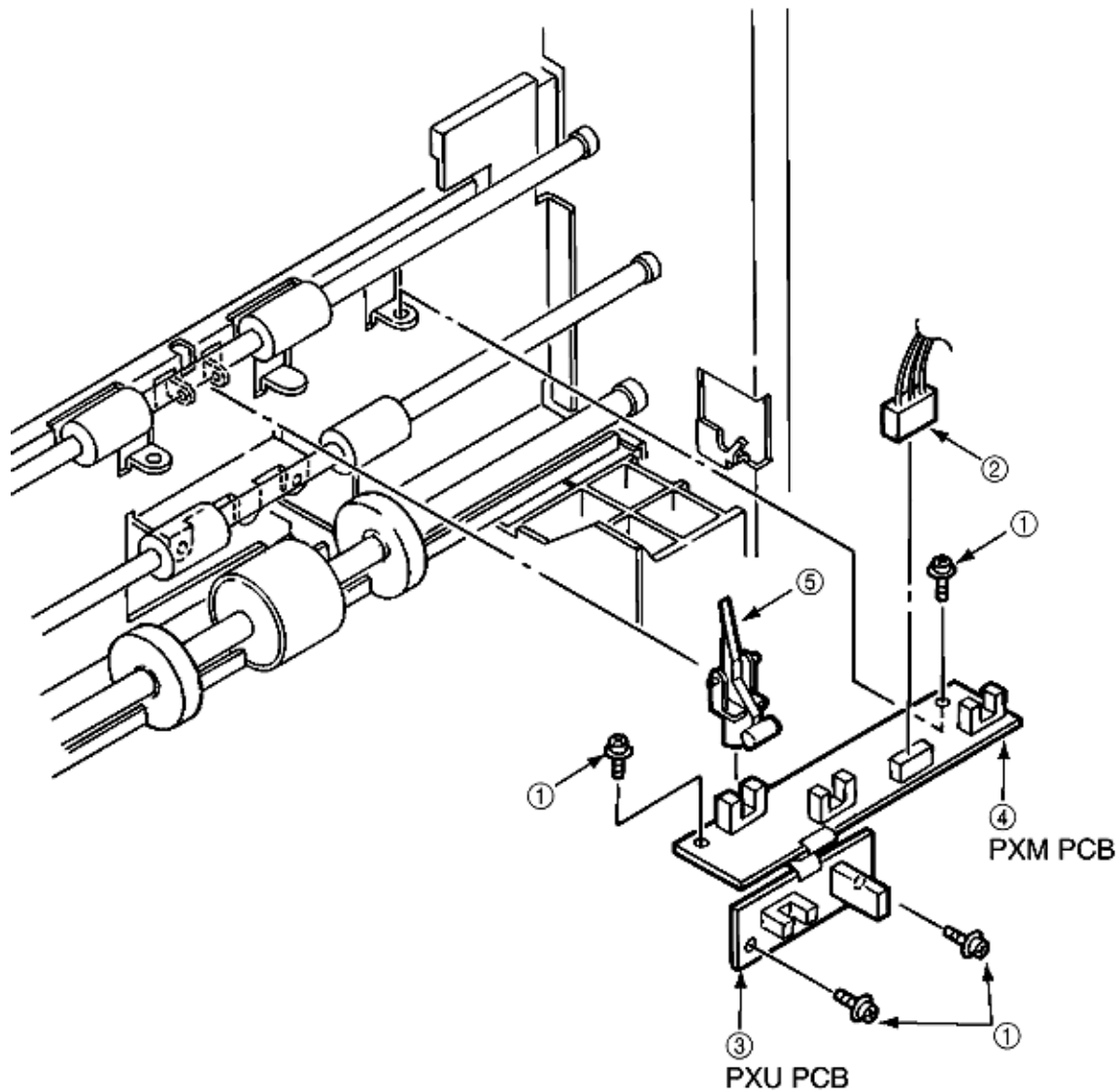
Figure 3.3.26 Hopping Roller Assy



### 3.3.27 PXU PCB/PXM PCB, Lever Resist Sensor

Since the PXU PCB and PXM PCB are connected with each other via the cable, remove them at the same time.

1. Remove the guide paper input assy. (See 3.3.23.)
2. Unscrew 4 screws (1) and unplug the cable (2), then remove the PXU PCB (3) and PXM PCB (4) at the same time.
3. Remove the lever resist sensor (5) by releasing the engagement with the guide.



**Figure 3.3.27 PXU PCB/PXM PCB, Lever Resist Sensor**



### 3.3.28 Paper End Lever

1. Remove the guide paper input assy. (See 3.3.23.)
2. Remove the paper end lever (1) by releasing the engagement with the guide.

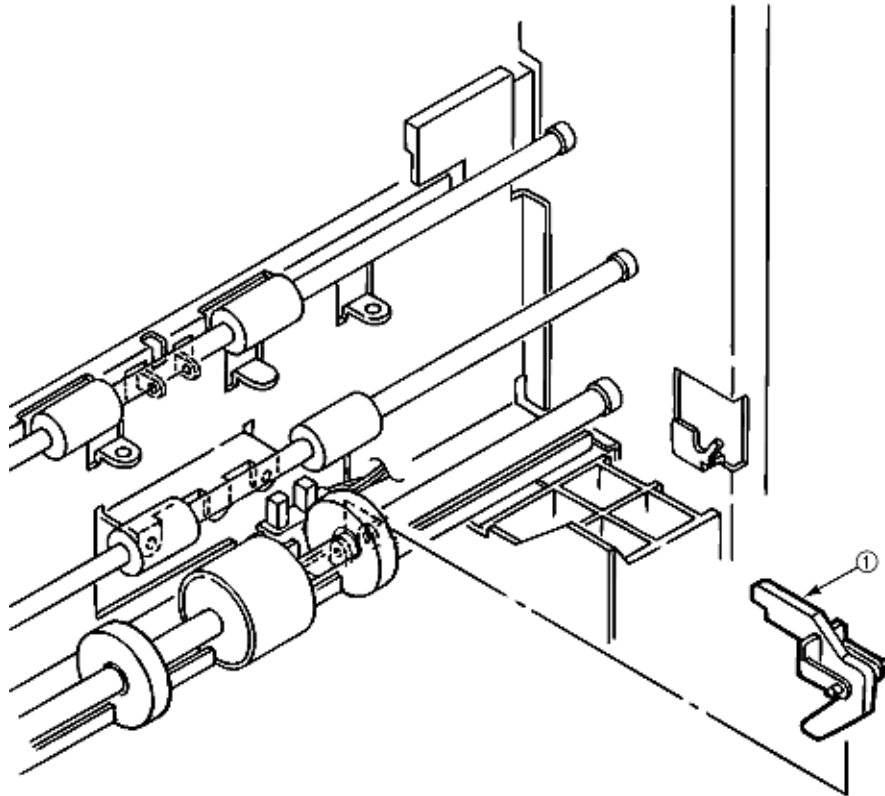


Figure 3.3.28 Paper End Lever



### 3.3.29 PCO PCB (Operator Panel)

1. Remove the cover assy side (R), and the cover assy OP panel. (See 3.3.8.)
2. Unscrew 4 screws (1) and unplug the operator panel cable (2).
3. Remove the PCO PCB (3) by releasing 6 claws (4) and (5) which are detached together).

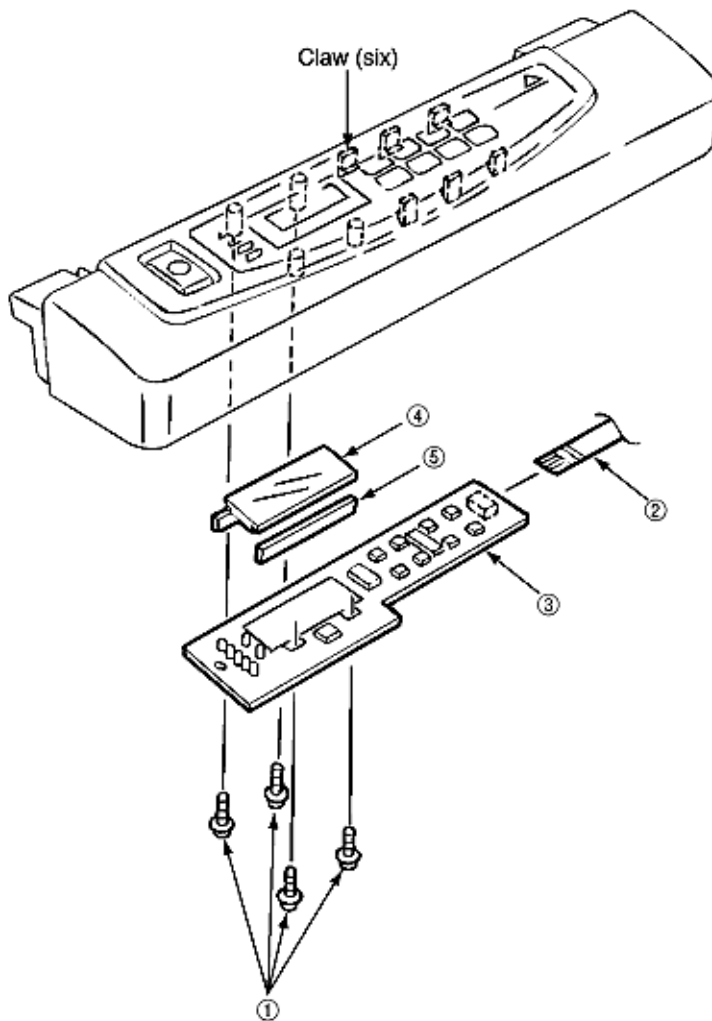


Figure 3.3.29 PCO PCB (Operator Panel)





### 3.3.30 Holder Gear Toner Assy

1. Remove the cover assy side (R), cover assy OP panel, cover front (R) and the cover front (L). (See 3.3.8.)
2. Unplug the cable (1) and unscrew the screw (2), then remove the holder gear toner assy (3).

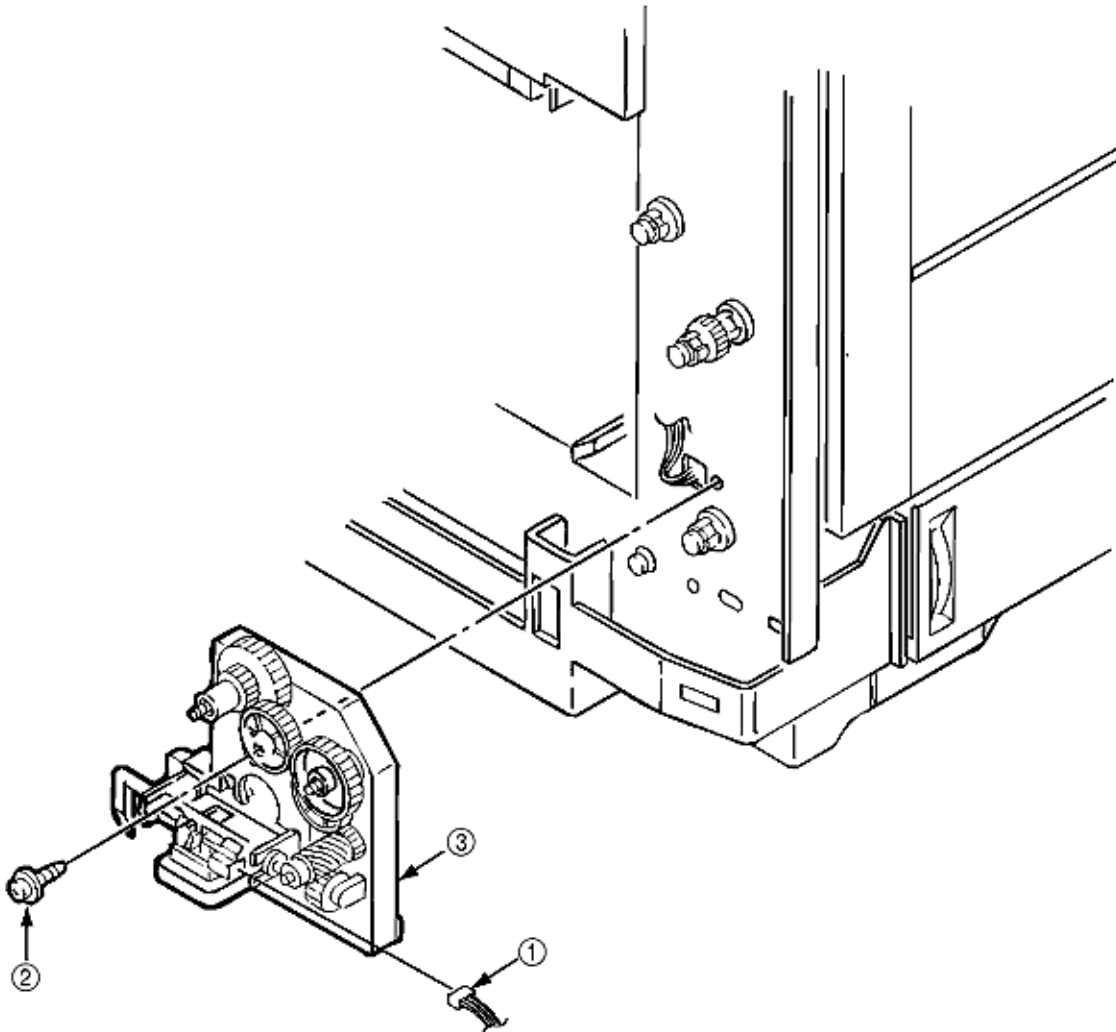
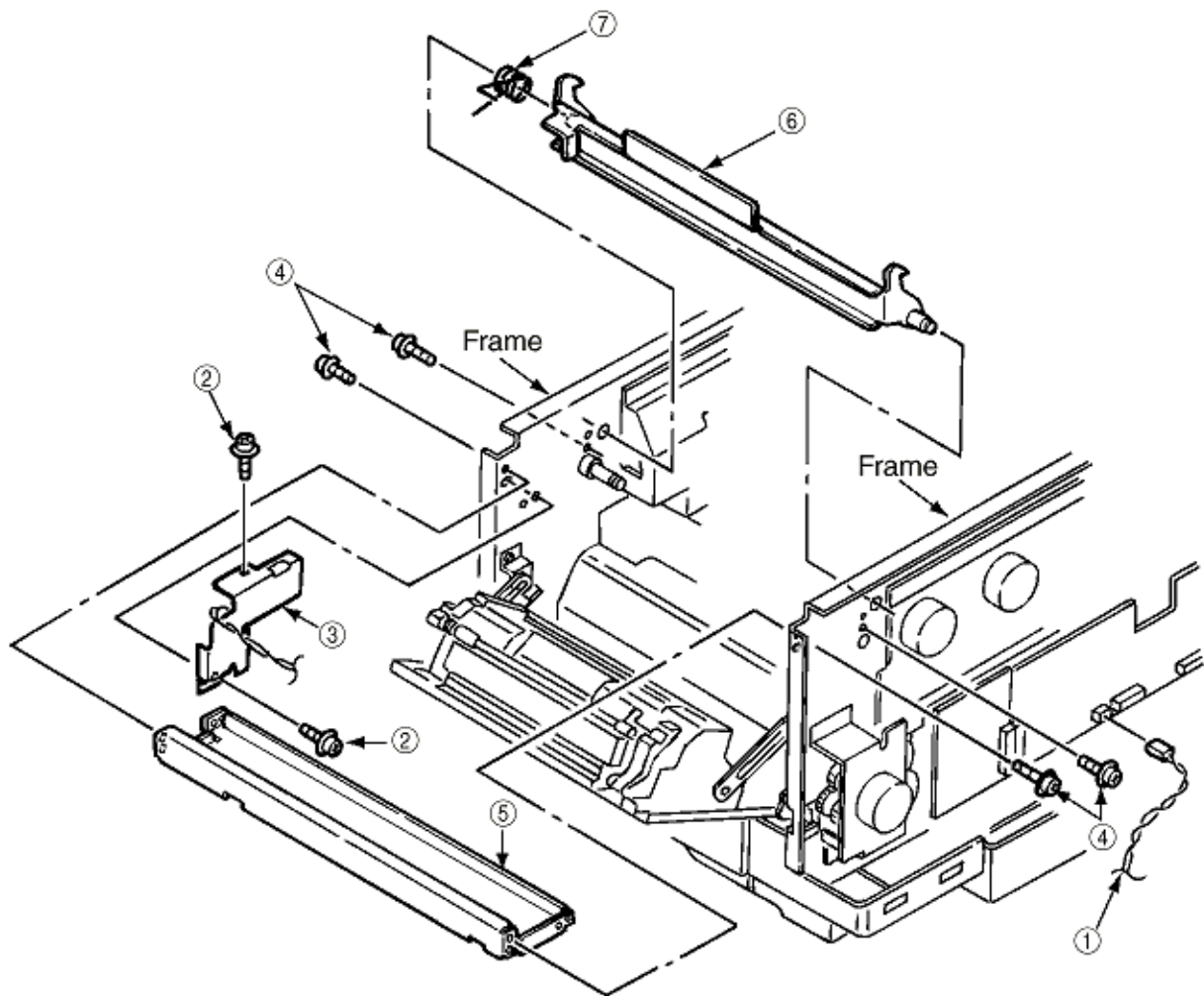


Figure 3.3.30 Holder Gear Toner Assy



**3.3.31 Plate Latch Lever (FD), Spring Latch Lever (FD)**

1. Remove the cover assy side (R), cover assy OP panel, cover front (R) and the cover front (L). (See 3.3.8.)
2. Open the cover CU. (See 3.3.11)
3. Unplug the cable (1).
4. Unscrew 4 screws (4) then remove the stay upper (front) (5).
5. Unscrew 2 screws (2) then remove the bracket SW (side) (5).
6. Remove the plate latch lever (FD) (6) and spring latch lever (FD) (7) with the side frames spread. **(Be careful not to spread the frames too much).**



**Figure 3.3.31 Plate Latch Lever (FD), Spring Latch Lever (FD)**



### 3.3.32 Transfer Belt

1. Open the Top cover.
2. Release the lock by drawing the cover knob then open the cover assy side (L).
3. Turn the waste toner box (box toner assy) (1) to the left by pressing it down, then remove it.
4. Draw out the belt cassette assy (2) by lifting it a little bit with its handle.

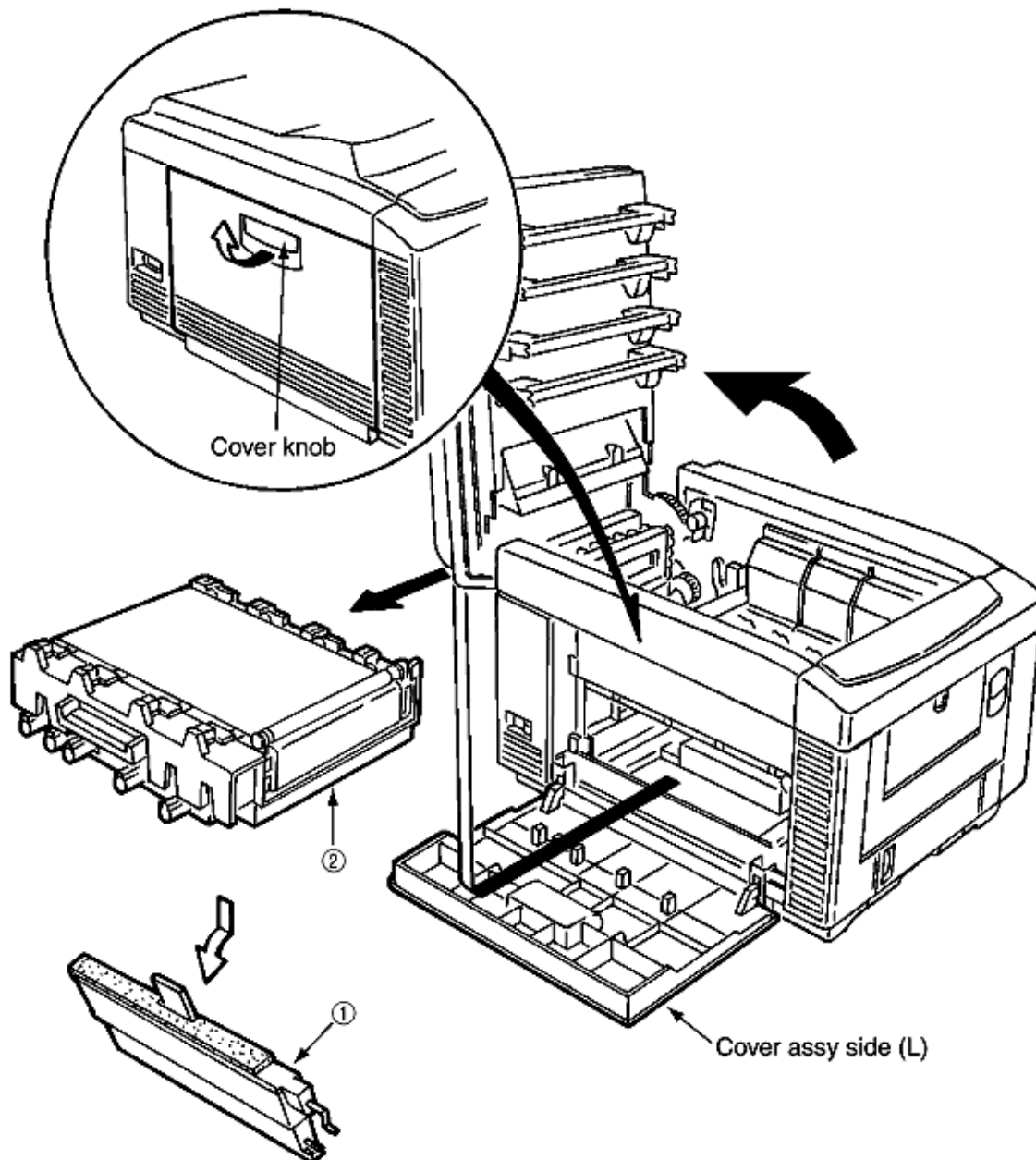


Figure 3.3.32 Transfer Belt





---

### 3.3.33 High Voltage Power Supply Unit, Bracket HV (BT) Assy

1. Remove the belt cassette assy. (See 3.3.32)
2. Unscrew 2 screws (1) with the stacker cover opened, then remove the plate HV (2).
3. Unplug the cable (3) and 7 codes (4).
4. Unscrew 2 screws (5) then remove the high voltage power supply unit (6).
5. Remove the bracket HV (BT) Assy (7).

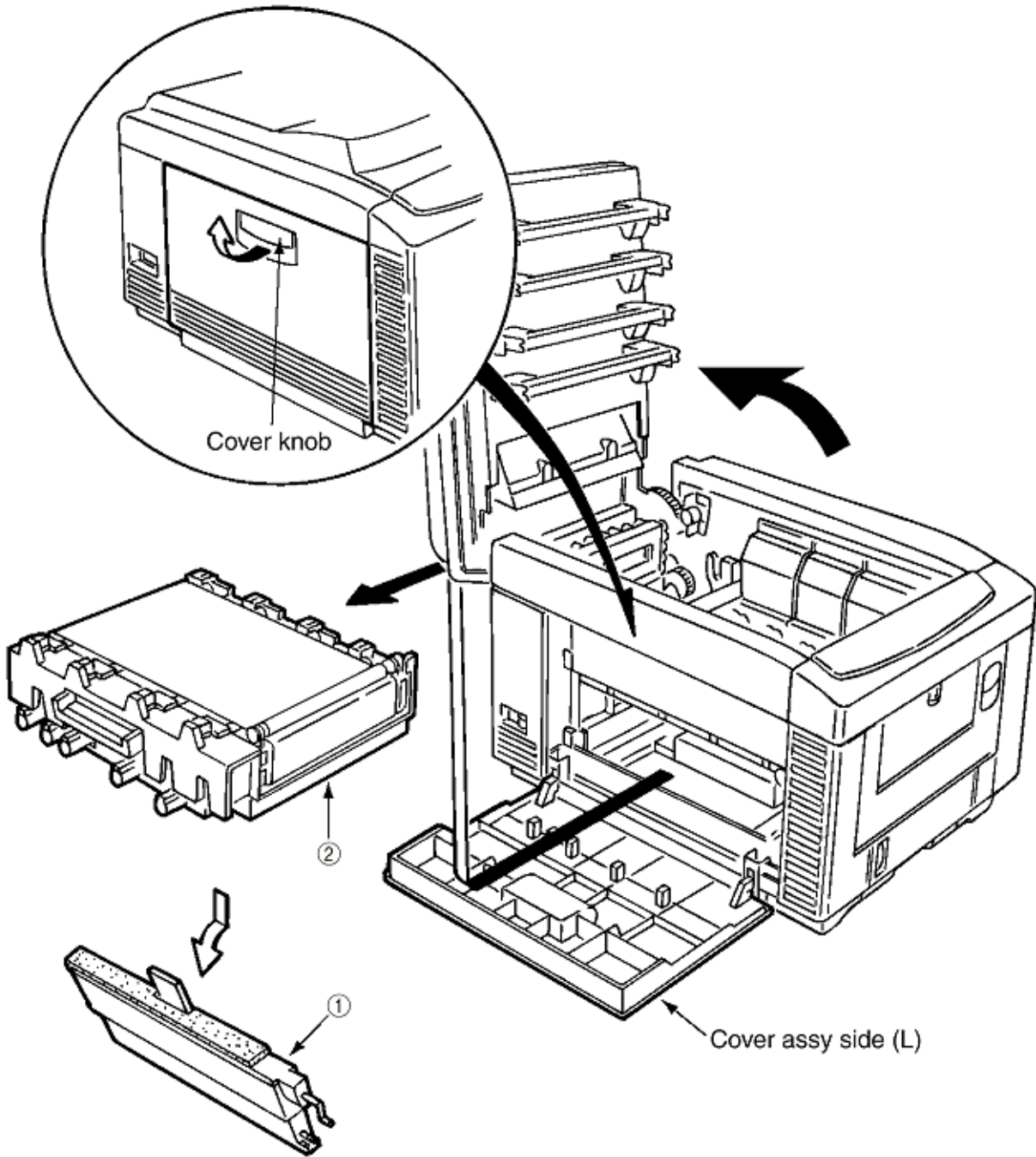


Figure 3.3.33 High Voltage Power Supply Unit, Bracket HV (BT) Assy



---

**3.3.34 Eraser Bracket Assy, Eraser Bracket (KCM) Assy**

1. Remove the belt cassette assy. (See 3.3.32).
2. Open the stacker cover.
3. Remove four screws (5) and then remove the Plate Blind (6).

**[Removing the eraser bracket assy]**

4. Remove the screw (1) and the connector (2).
5. Release the screw (7) and then remove the eraser bracket assy (3).

**[Removing the eraser bracket (KCM) assy]**

6. Remove the screw (1) and the connector (2).
7. Release the lock of the claw then release the engagement with the bracket sensor T (KCM). (See 3.3.35).
8. Release the screw (7) and then remove the eraser bracket (KCM) assy (4) and unplug the cable (2) then remove the eraser bracket (KCM) assy.

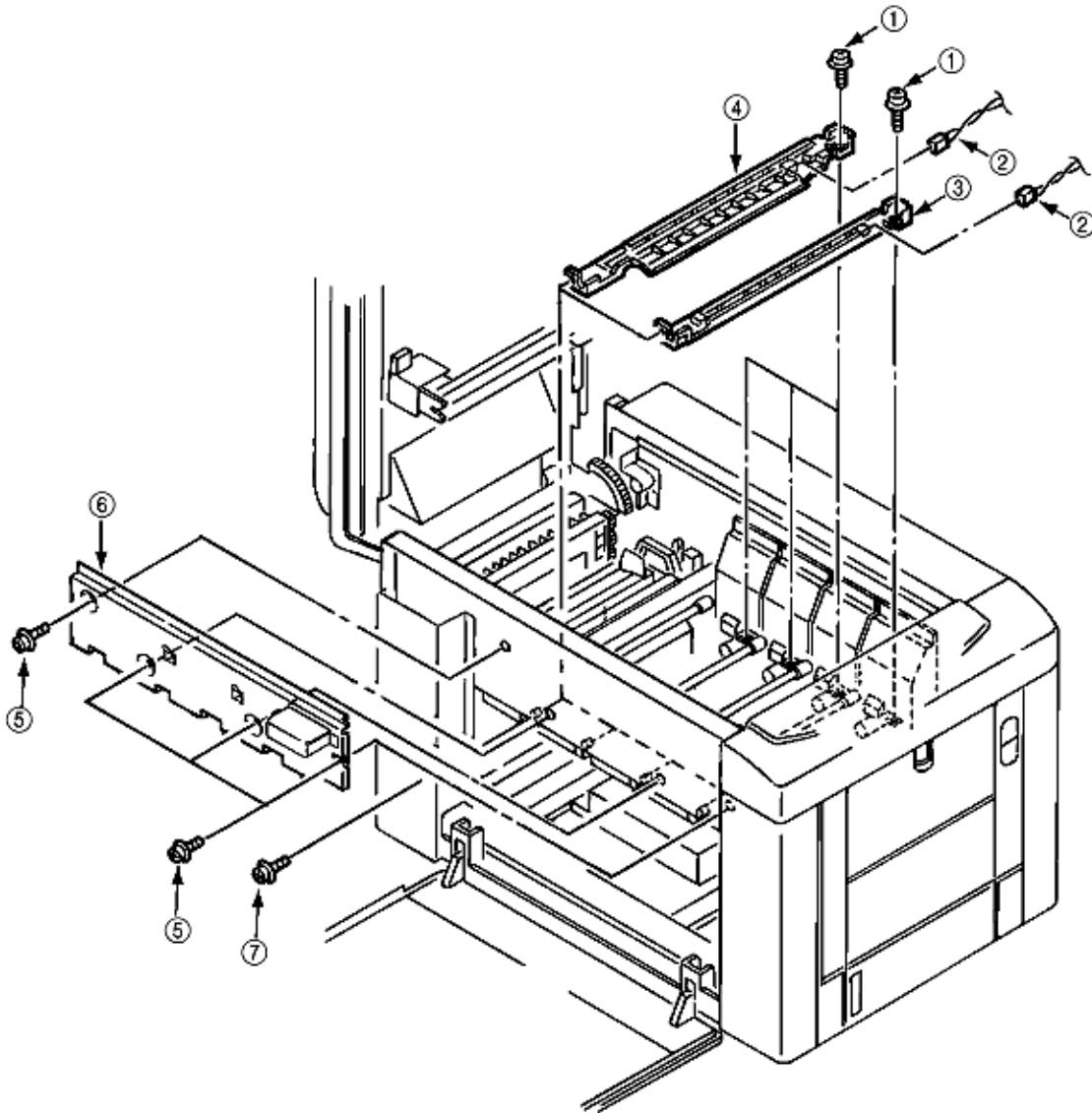


Figure 3.3.34 Eraser Bracket Assy, Eraser Bracket (KCM) Assy





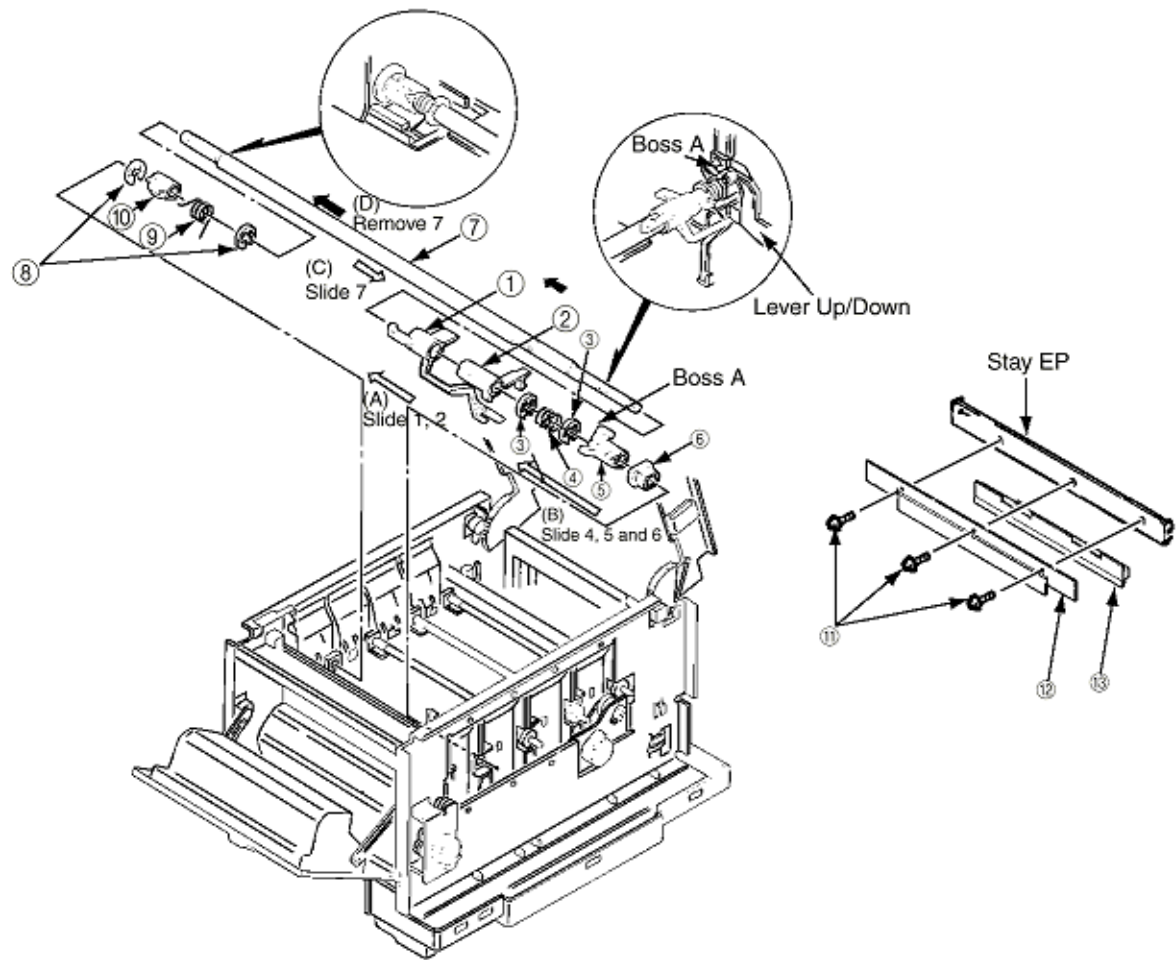
---

### 3.3.35 Shaft Link

1. Remove the eraser bracket assy. (See 3.3.34)
2. Remove the gear one-way (Z30). (See 3.3.14.)
3. Remove the E-ring (3) by sliding the sensor assy T (KCM) (1) and bracket sensor T (KCM) (2) together in the arrow (A) direction.
4. Release the engagement between the lever Up/Dn and boss A of the lever link (R) (5) by sliding the spring support (R) (4), lever link (R) (5) and the bearing (6) together in the arrow (B) direction. **(Keep on sliding until the lever link (R) (5) reaches the end of D-cut part of the shaft link (7).)**
5. Draw out the entire shaft link (7) by pressing it in the arrow (C) direction and turning its left side under the contact (BL L) assy.
6. Detach the sensor assy T (KCM) (1), bracket sensor T (KCM) (2), spring support (R) (4), lever link (R) (5) and the bearing (6) from the shaft link (7).
7. Remove 2 E-rings (8) then remove the spring support (L) (9) and lever link (L) (10).

#### **[Notice for mounting]**

- Engagement between the lever Up/Dn and boss A of the lever link (R) (5): Mount the spring support (L) (9) and lever link (L) (10) in the predetermined positions, then clamp the boss A of lever link (R) (5) with the lever Up/Dn by adding rotating power on the spring support (L) (9) by rotating the shaft link (7).
- Mounting of the spring support (R) (4): Clamp the spring support (R) (4) at the predetermined positions in the lever link (R) (5) and the contact BKT (R).



**Figure 3.3.35 Shaft Link**



**3.3.36 Contact Bracket (BL-R) Assy, Contact Bracket (CL-R) Assy**

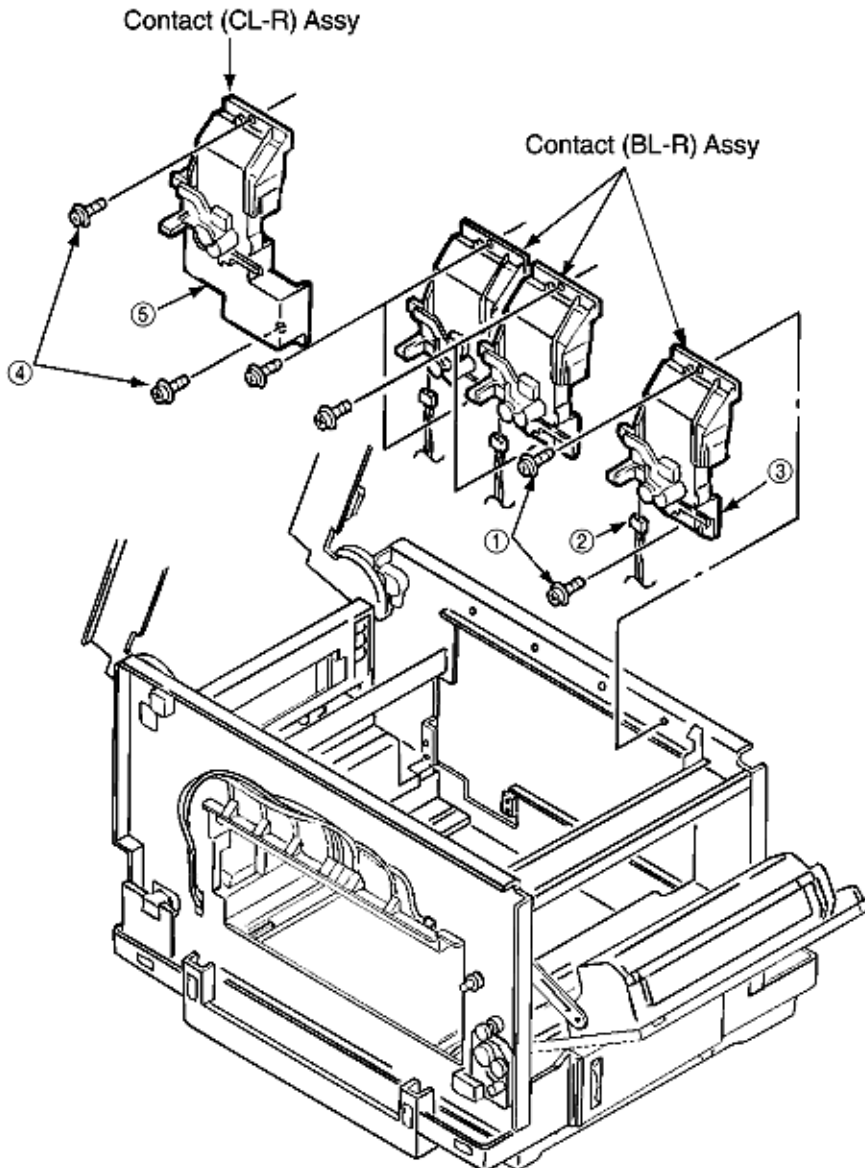
1. Remove the gear one-way (Z30). (See 3.3.14)
2. Remove the motor assy BT. (See 3.3.15)
3. Remove the high voltage power supply unit. (See 3.3.33)
4. Remove the shaft link. (See 3.3.35)

**[Removal of the contact (BL-R) Assy]**

5. Unscrew 2 screws (1) and unplug the cable (2), then remove the contact (BL-R) assy (3).

**[Removal of the contact (CL-R) Assy]**

6. Unscrew 2 screws (4) then remove the contact (CL-R) Assy (5).



**Figure 3.3.36 Contact Bracket (BL-R) Assy, Contact Bracket (CL-R) Assy**

---

Copyright 1999, Okidata, Division of OKI America, Inc. All rights reserved.



**3.3.37 Contact (BL-L) Assy, Contact (CL-L) Assy**

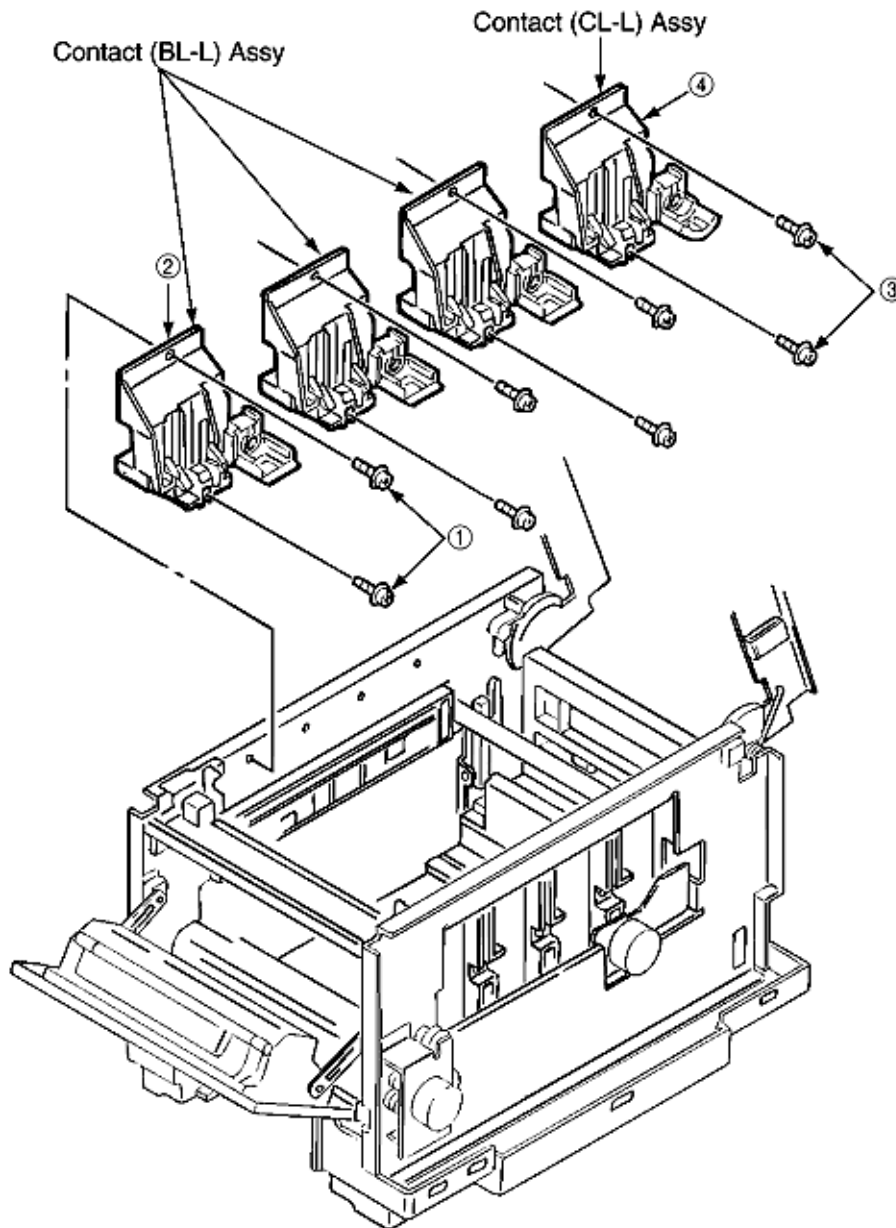
1. Remove the shaft link. (See 3.3.35)

**[Removal of the contact (BL-L) assy]**

2. Unscrew 2 screws (1) then remove the contact (BL-L) Assy (2).

**[Removal of the contact (CL-L) assy]**

3. Unscrew 2 screws (3) then remove the contact (CL-L) assy (4).



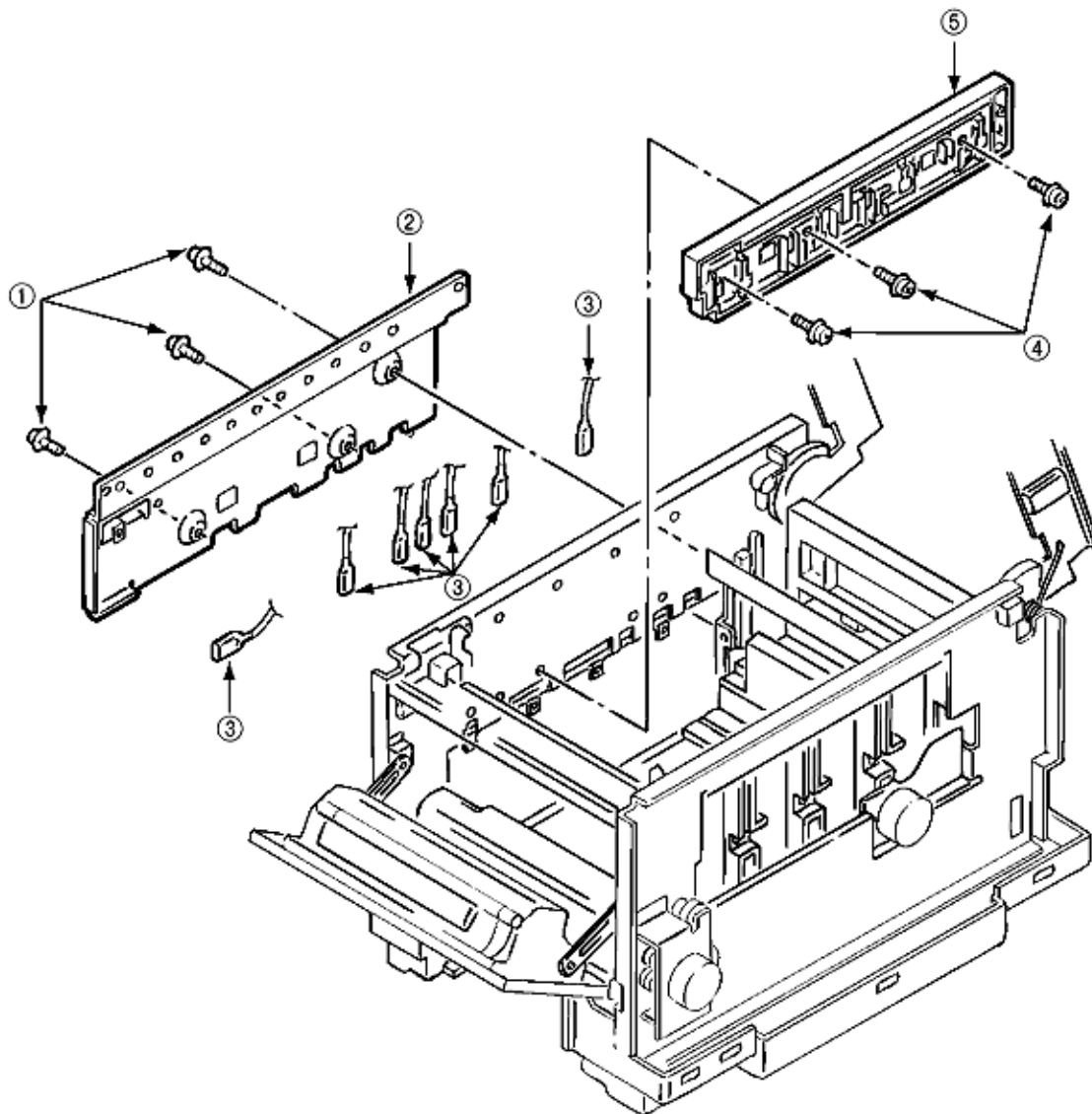
**Figure 3.3.37 Contact (BL-L) Assy, Contact (CL-L) Assy**





**3.3.38 Contact SB Assy**

1. Remove the contact (BL-L) Assy and contact (CL-L) Assy. (See 3.3.37)
2. Unscrew 3 screws (1) then remove the plate blind (2).
3. Unplug 7 codes (3).
4. Unscrew 3 screws (4) then remove the contact SB Assy (5).



**Figure 3.3.38 Contact SB Assy**



---

### 3.3.39 PXC PCB

1. Remove the contact (BL-R) assy and contact (CL-R) assy. (See 3.3.36)
2. Remove the contact (BL-L) assy and contact (CL-L) assy. (See 3.3.37)
3. Remove the hopping motor. (See 3.3.19)
4. Remove the motor assy BT. (See 3.3.15)
5. Remove the gear heat assy. (See 3.3.12)
6. Remove the roller assy hopping. (See 3.3.25)
7. Remove the holder gear toner assy. (See 3.3.30)
8. Remove the high voltage power supply unit. (See 3.3.33)
9. Unplug the inlet AC. (See 3.3.16)
10. Unscrew 9 screws (1) then remove the guide cassettes (L) (2) and (R) (3) together.
11. Unscrew the screw (4) then remove the switch (5).
12. Unscrew the screw (6) then remove the PXC PCB (7).



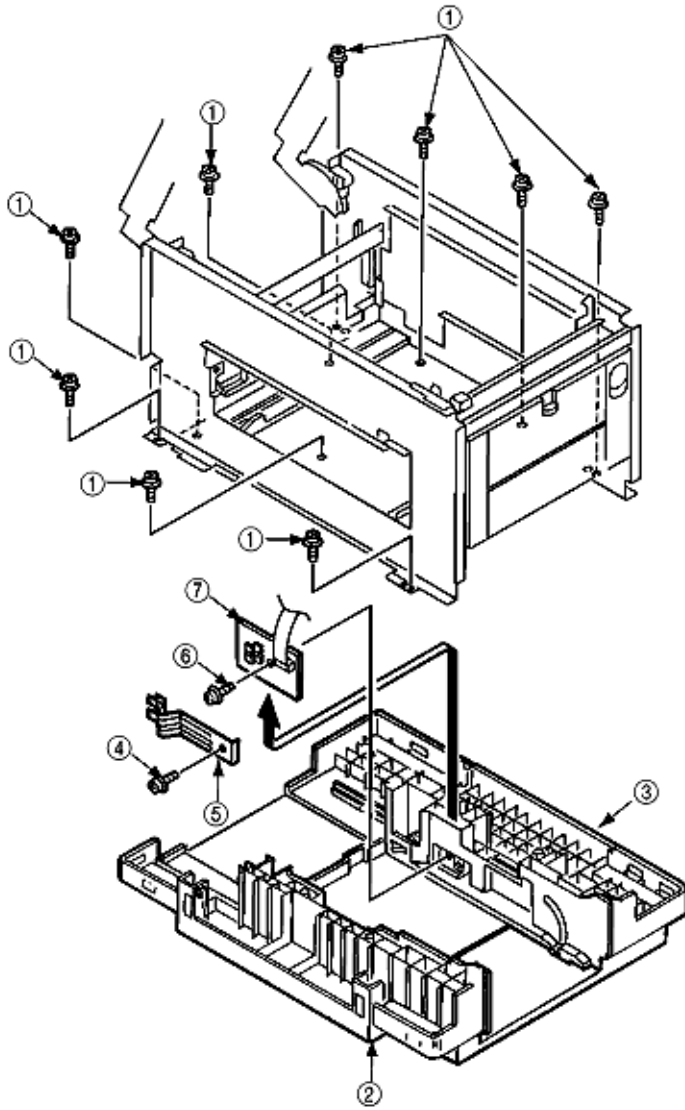
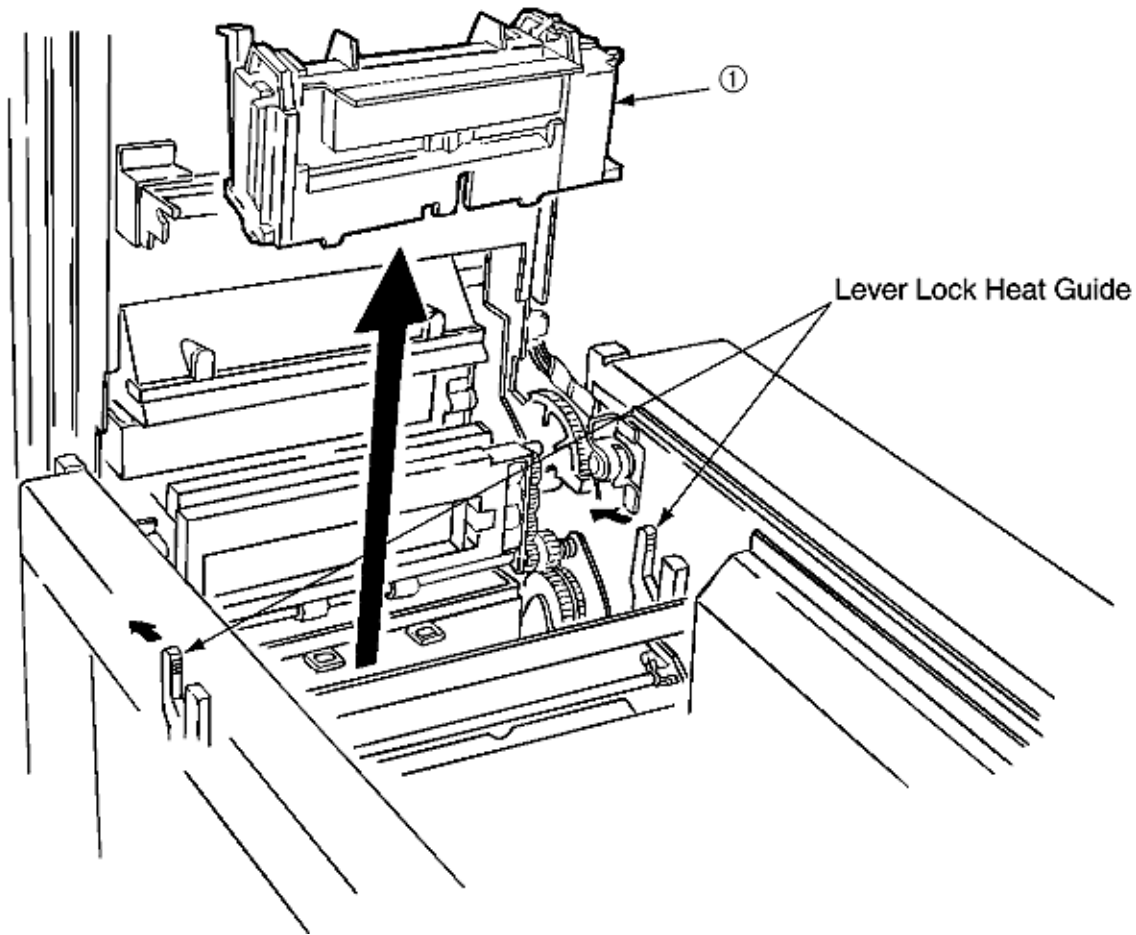


Figure 3.3.39 PXC PCB



**3.3.40 Heat Unit Assy (Fuser unit and oil roller)**

1. Open the stacker cover.
2. Release the lock by turning down the lever lock heat guides (blue) on both sides, then lift the fuser unit assy (1) and remove it.

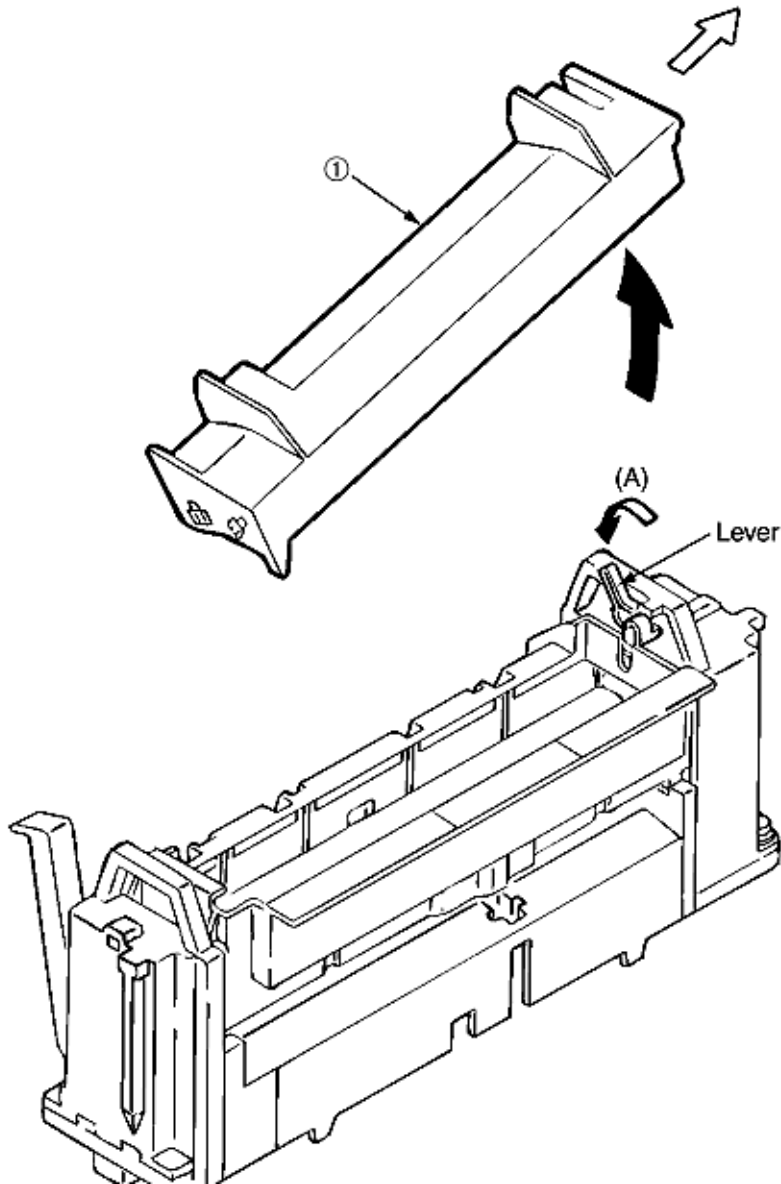


**Figure 3.3.40 Heat Unit Assy**



**3.3.41 Oil Roller Kit**

1. Remove the heat unit assy. (See 3.3.40)
2. Release the lock by turning down the lever in the arrow (A) direction, then slide the oil roller assy (1) with its right side lifted and remove it.



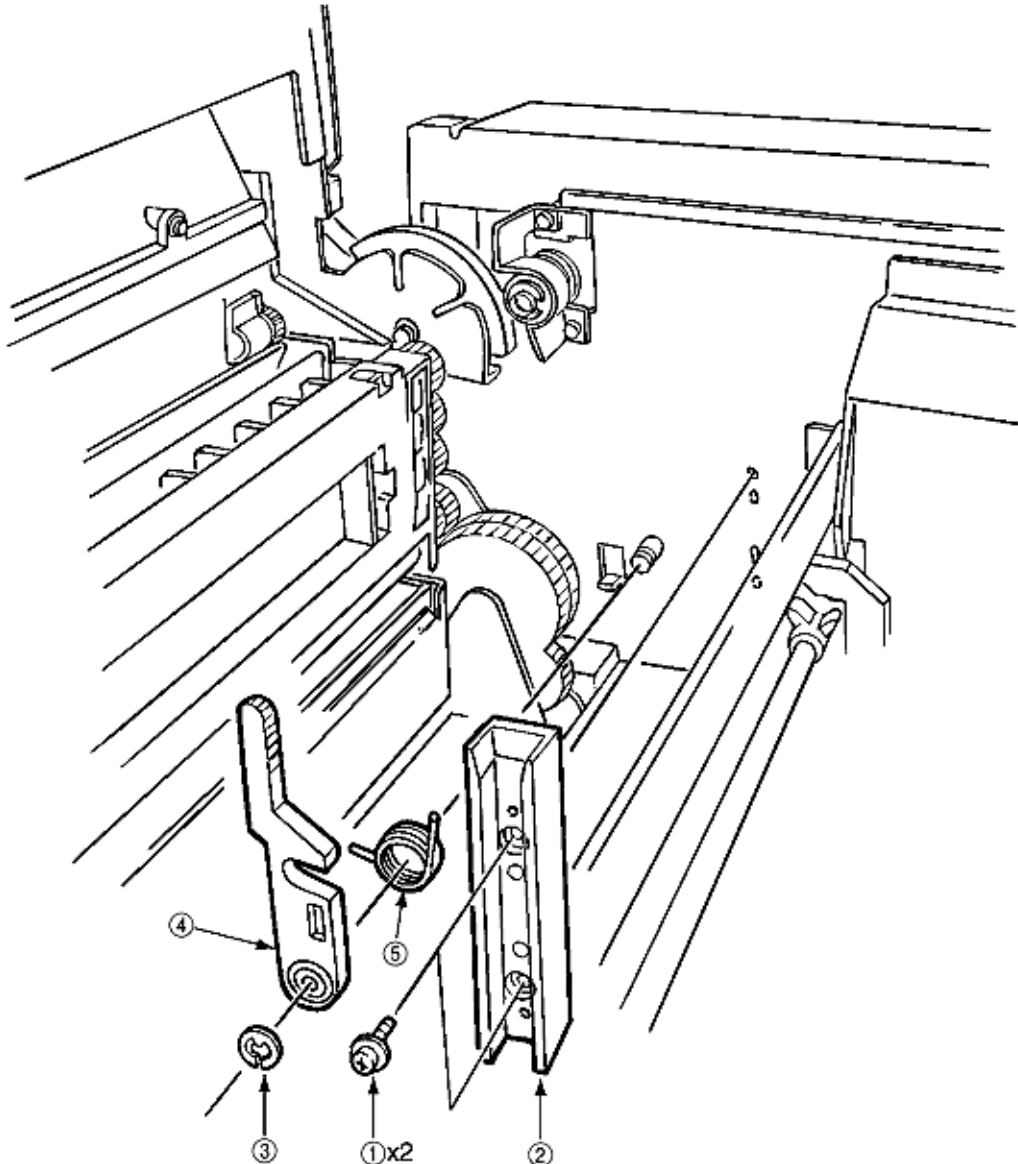
**Figure 3.3.41 Oil Roller Kit**



**3.3.42 Lever Lock Heat (L)/(R), Guide Side Heat, Spring Lock**

Removing methods for right side and left side of each part are the same. Here describes the method for right side.

1. Remove the heat unit assy. (See 3.3.40)
2. Unscrew 2 screws (1) then remove the guide side heat (2).
3. Remove the E-ring (3) then lever lock heat (R) (4). **(Be careful not to lose the spring lock 5 which slips off together.)**



**Figure 3.3.42 Lever Lock Heat (L)/(R), Guide Side Heat, Spring Lock**



### 3.3.43 PXL PCB

1. Remove the paper eject Assy. (See 3.3.3)
2. Remove the belt cassette Assy. (See 3.3.32)
3. Remove the heat unit Assy. (See 3.3.40)
4. Unplug the cable (1) and the screw (2), then remove the PXL PCB (3).
5. Release the lock of the claw then remove the sensor cover (4).

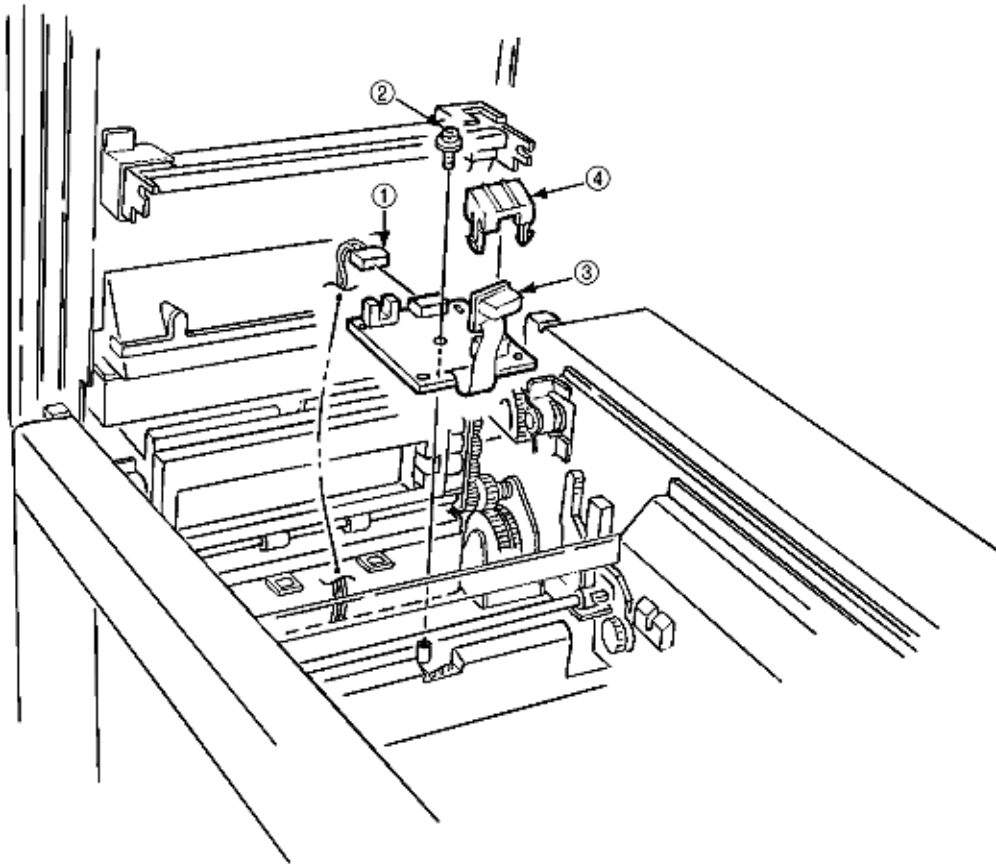


Figure 3.3.43 PXL PCB



---

### 3.3.44 Heat Unit Guide Assy

1. Remove the cover assy rear. (See 3.3.1)
2. Remove the paper eject assy. (See 3.3.3)
3. Remove the gear heat assy. (See 3.3.12)
4. Remove the belt cassette assy. (See 3.3.32)
5. Open the stacker cover and remove the heat unit assy. (See 3.3.40)
6. Unscrew 4 screws (1) then remove the heat unit guide assy (2).

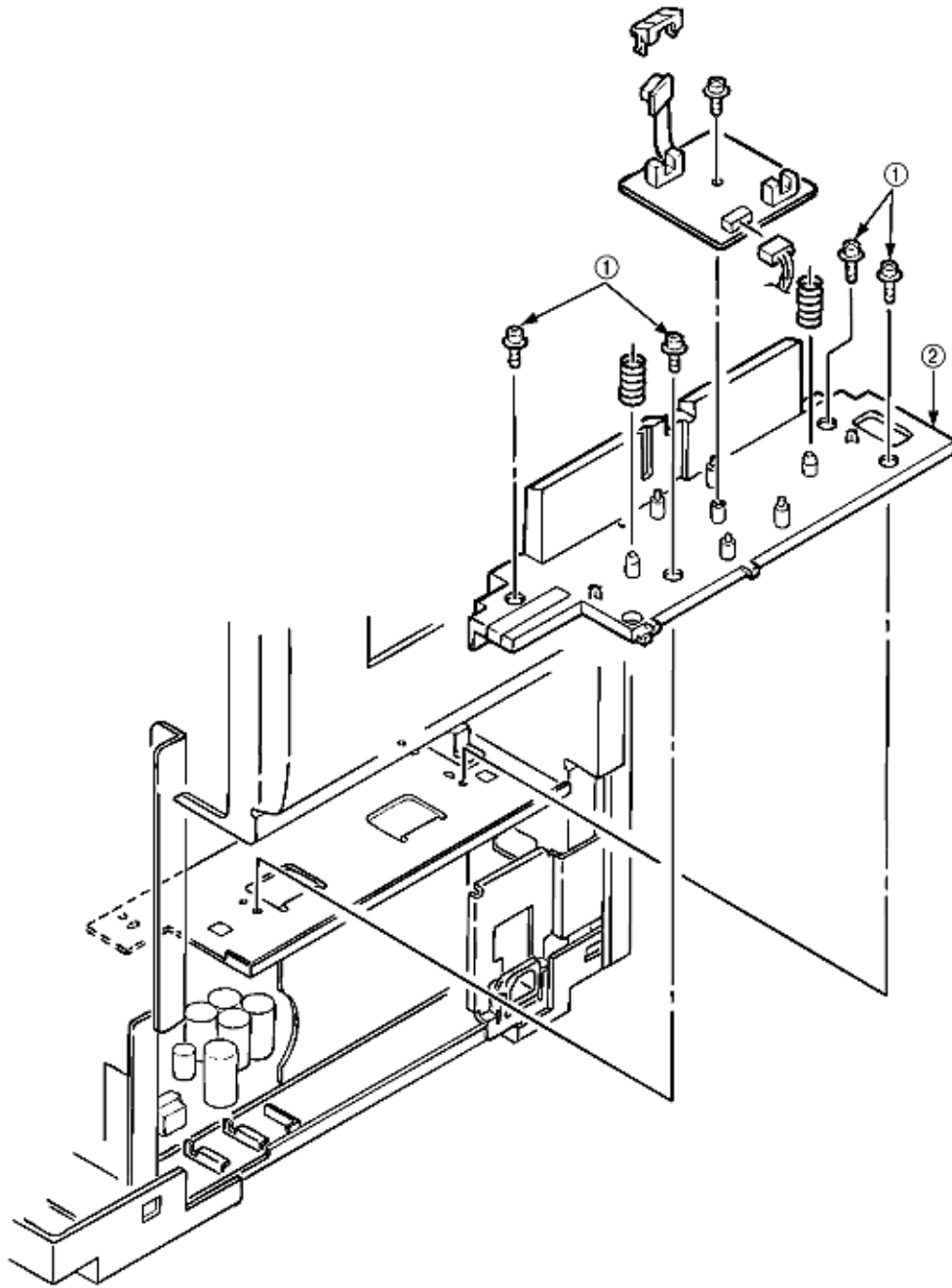
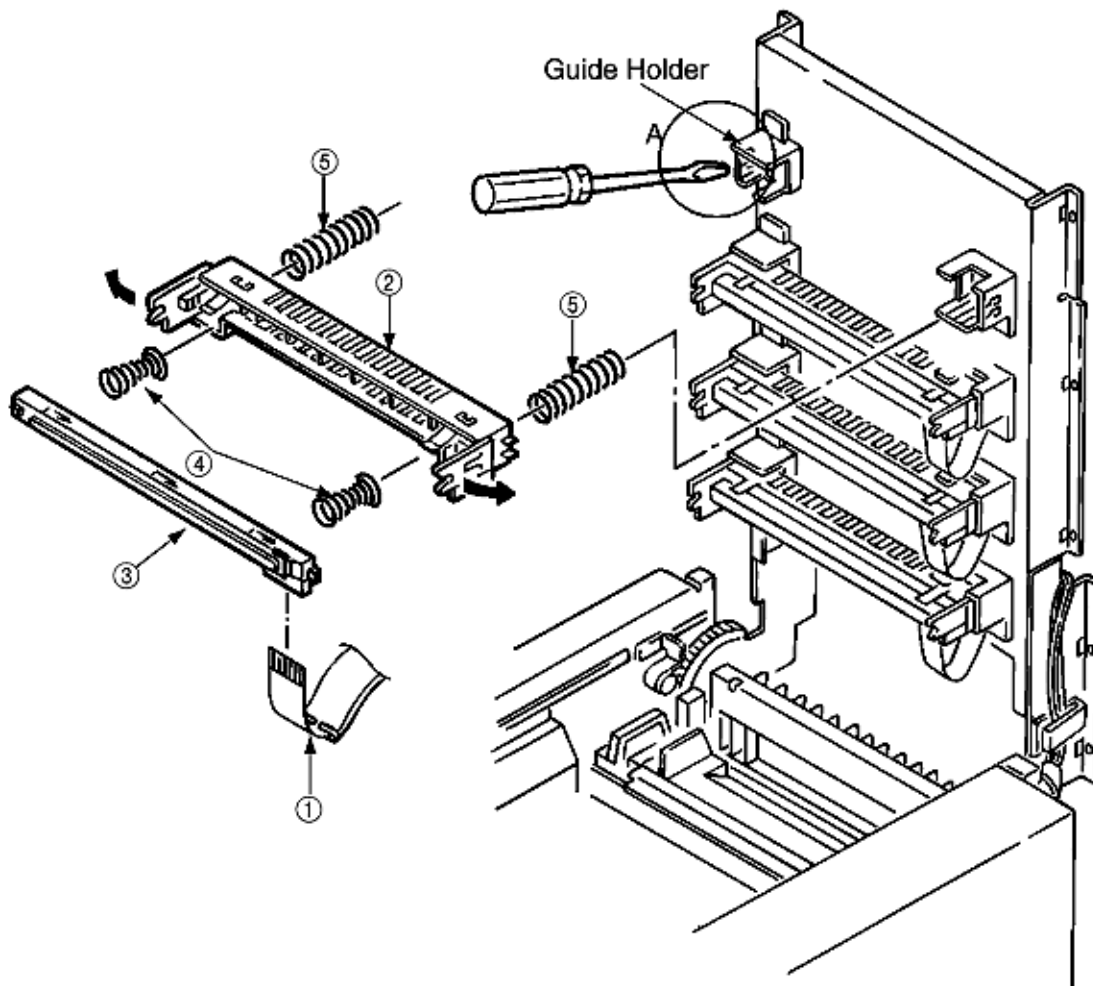


Figure 3.3.44 Heat Unit Guide Assy



**3.3.45 Holder LED Assy, LED Head**

1. Unplug the cable (1).
2. Remove the LED head (3) by spreading the holder LED assy (2) a little bit. (Be careful not to lose the spring (4) which slips off together.)
3. Remove the holder LED assy (2) by spreading the A-part of the guide holder a little bit with a flat blade screwdriver. (Be careful not to lose the spring (5) which slips off together.)



**Figure 3.3.45 Holder LED Assy, LED Head**

Copyright 1999, Okidata, Division of OKI America, Inc. All rights reserved.





---

#### **4. Adjustments**

Adjustments are carried out by key operations on the operator panel, by software operation panel, and by EEPROM of PU (PX4-PCB) setting.

This page printer supports three maintenance modes. Select and enter a maintenance mode fit for the adjustment.

#### **4.1 Maintenance Modes and Their Functions**

#### **4.2 Adjustments after Parts Replacement**



---

**4.1 Maintenance Modes and Their Functions**

**4.1.1 User maintenance mode**

**4.1.2 System maintenance mode**

**4.1.3 Engine maintenance mode**



#### 4.1.1 User maintenance mode

To enter the user maintenance mode, press and hold the MENU key while powering on the printer.

- Functions

- Menu reset
- Resource save area
- Operator panel menu disable
- Y adjust
- Hex dump
- Receive buffer size
- X adjust

(a) **Menu reset**

1. Resets all Menu Level 1 settings to the default settings (which have been factory-set).
2. Resets all executable Emulation menu items (including options) to factory-set default emulation items.

(b) **Hex dump**

1. Receives data from the host computer and dumps it in a hexadecimal format.
2. When one or more page of data come from the host, printing automatically starts. To print out data of less than one page, press the ONLINE key to set the offline state and press the EJECT key. Printing starts.
3. To exit this mode, shut off power to the page printer. This is the only way to exit this mode.

(c) **Resource save area**

Sets the resource saving area. This menu item appears when the option PS SIMM and RAM increases. The selectable size will also increase. When adding RAM over 24Mbytes, the selection can be made up to 22.5Mbytes. The size upon auto will also increase if the size of the add-on RAM increases.

(d) **Receive buffer**

Sets the receive buffer. The data transmission time from the upper command will decrease when set to a high value, but memory overflow is more likely to occur. Memory will be restructured with this change, and the contents of all download fonts, PCL macro, and PostScript will be lost.

(e) **Operator panel menu disable**

Enables or disables the menu functions (Menu1, Menu2, Tray Type, Power Save, and Paper Size) of the operator panel.

(f) **X adjust**

1. Corrects the position of the whole print image so that it may be perpendicular to the movement of paper (at intervals of 0.25mm).
2. The print image exceeding the specified printable area is clipped.

(g) **Y adjust**

1. Corrects the position of the whole print image so that it parallels the movement of paper (at intervals of 0.25mm).
2. The print image exceeding the specified printable area is clipped.

### User maintenance mode menu system

Category	Selection	DF	After pressing [ENTER] key	After completing the process
MENU RESET			MENU RESETTING	MENU RESET
HEX DUMP			ON-LINE HEX DUMP	

RESOURCE SAVE	AUTO OFF 400KB 900KB 1.6MB 2.5MB * * * 19.6MB 22.5MB	*		
RECEIVE BUFFER	AUTO 100KB 512KB 1MB	*		
ECP	ENABLE DISABLE	*		
OP MENU	ENABLE DISABLE	*	SETTING EEPROM	
X ADJUST	0 mm +0.25 mm +0.50 mm ~ +2.00 mm -2.00 mm 1.75 mm ~ -0.25 mm	*	SETTING EEPROM	
Y ADJUST	0 mm +0.25 mm +0.50 mm ~ +2.00 mm -2.00 mm -1.75 mm ~ -0.25 mm	*	SETTING EEPROM	



#### 4.1.2 System maintenance mode

To set the system maintenance mode, turn on the power switch of the page printer while pressing on Recover key.

**Note:** The system maintenance mode is hidden and not available to the user.

To exit this mode, press the ONLINE switch except during rolling ASCII continuous printing. Then the RUN mode is set.

In the system maintenance mode, the category changes each time the MENU switch is pressed. The last category wraps around to the first category. The system maintenance mode supports the following functions:

<ul style="list-style-type: none"> <li>● Page count display</li> <li>● Rolling ASCII continuous printing</li> <li>● HSP ERROR recovery</li> <li>● HSP ERROR count reset</li> </ul>	<ul style="list-style-type: none"> <li>● Page count printing enable/disable</li> <li>● EEPROM reset</li> <li>● HSP ERROR count display</li> </ul>
--	---

##### (1) Page count display

- The total number of pages counted at the engine is displayed on the operator panel.

##### (2) Page count printing enable/disable

- This function selects whether to include (enable) or exclude (disable) the total number of printed pages counted at the engine at the time of menu printing.

##### (3) Rolling ASCII continuous printing

- The rolling ASCII pattern is printed continuously for various engine tests.
- Press the ON-LINE key to cancel this mode.

##### (4) EEPROM reset

- All EEPROM areas (including Menu level-2) to the factory default values.
- The following items are excluded

Head drive time setting

ENGINE Maintenance Item

Revision (Including Destination setting)

##### (5) HSP ERROR recovery

- Select HSP ERROR recovery function either recover or stop.

##### (6) HSP ERROR count

- Display total HSP ERROR count.

##### (7) HSP ERROR count reset

- Reset the HSP ERROR counter.

## System Maintenance mode menu system

Category	Selection	DF	After pressing [ENTER] key	After completing the process
PAGE CNT nnnnnn				
PAGE PRT	DISABLE ENABLE	*		
CONT PRT			CONT PRT PRINTING	CONT PRT CANCELLED (Press the ONLINE button).
EEPROM RESET			EEPROM RESETTING	
HSPERR	RECOVER STOP	*	SETTING EEPROM	
HSPERR CNT nn				
HSPERR CNT RST			HSPERR RESETTING	HSPERR CNT RST

---

Copyright 1999, Okidata, Division of OKI America, Inc. All rights reserved.



#### **4.1.3 Engine maintenance mode**

To set the engine maintenance mode, turn on the power switch of the page printer while pressing the ENTER and FORM FEED keys. The engine maintenance mode is set and "ENG MNT" is displayed on-screen.

**Note:** The engine maintenance mode is hidden and not available to the user.

To exit this mode, press the ONLINE switch. The operation mode is entered. The engine maintenance mode supports the following functions:

- Head drive time setting (CYAN, MAGENTA, YELLOW, BLACK)
- Drum count display (CYAN, MAGENTA, YELLOW, BLACK)
- Total drum count display (CYAN, MAGENTA, YELLOW, BLACK)
- Fuser count display
- Belt count display
- Oil roller count display
- Setting of standard tray paper feed length
- Setting of second tray paper feed length
- Setting of front feeder paper feed length
- Engine reset

**(1) Head drive time setting (Cyan, Magenta, Yellow, and Black)**

Sets the time of driving each LED head.

**(2) Drum count display (Cyan, Magenta, Yellow, and Black)**

Displays the number of revolutions of each image drum counted by the engine on the LCD.

**(3) Total drum count display (Cyan, Magenta, Yellow, and Black)**

Displays the total number of rotations at each color.

**(4) Fuser count display**

Displays the total number of pages handled by the Fuser which have been counted by the engine.

**(5) Belt count display**

Displays the total number of pages handled by the Belt which have been counted by the engine.

**(6) Oil roller count display**

Displays the counter of the oil roller.

**(7) T1 position (Setting of standard tray paper feed length)**

Sets a value for correcting the amount of paper feeding of the standard tray.

**(8) T2 position (Setting of second tray paper feed length)**

Sets a value for correcting the amount of paper feeding of the second tray.

**(9) Engine reset**

- Resets the contents of all EEPROM areas used by the engine with default values.
- Does not reset the following items:
  - LED head drive time
  - Menu level 1
  - Menu level 2
  - Operator Panel Menu Disable/Enable

- Page Print Disable/Enable

### Engine Maintenance mode menu system (1/2)

Category	Selection	DF	After pressing [ENTER] key	After completing the process
CYAN LED HEAD	No. 1 No. 2 - No. 16 No. 17 - No. 32		SETTING EEPROM	
MAGENTA LED HEAD	No. 1 No. 2 - No. 16 No. 17 - No. 32		SETTING EEPROM	
YELLOW LED HEAD	No. 1 No. 2 - No. 16 No. 17 - No. 32		SETTING EEPROM	
BLACK LED HEAD	No. 1 No. 2 - No. 16 No. 17 - No. 32		SETTING EEPROM	

### Engine Maintenance mode menu system (2/2)

Category	Selection	DF	After pressing [ENTER] key	After completing the process
CYAN DRMCNT nnnn				
Cyan DRMCNT T nnnnnnn				
MAGENTA DRMCNT nnnn				
Magenta DRMCNT T nnnnnnn				
YELLOW DRMCNT nnnn				
Yellow DRMCNT T nnnnnnn				
BLACK DRMCNT nnnn				
Black DRMCNT T nnnnnnn				
FUSER COUNT nnnn				
BELT COUNT nnnn				
Oil Roller Count nnnnnnn				



T1 POSITION	0 mm +1 mm ~ +7 mm -8 mm ~ -1 mm	*	SETTING EEPROM	
T2 POSITION	0 mm +1 mm ~ +7 mm -8 mm ~ -1 mm	*	SETTING EEPROM	
FF POSITION	0 mm +1 mm ~ +7 mm -8 mm ~ -1 mm	*	SETTING EEPROM	
ENGINE REST			ENGINE RESETTING	ENGINE RESET



---

#### **4.2 Adjustments after Parts Replacement**

Adjustments required after parts replacement are listed below.

Adjustment and correction of color deviations are always required after parts are replaced.

<b>Part replaced</b>	<b>Adjustment required</b>
LED head	Set the LED head driving time and correct color deviations.
Drum cartridge (Y, M, C, and K)	Reset the drum counter and correct color deviations.
Fuser Unit	Reset the fuser counter and correct color deviations.
Belt cassette assembly	Reset the belt counter and correct color deviations.
EEPROM (PU block)	Set the LED head driving time and correct color deviations.
Oil Roller	Reset the oil roller counter.
Other parts	Correct color deviations (if any).

##### **4.2.1 Confirm the LED head driving time**

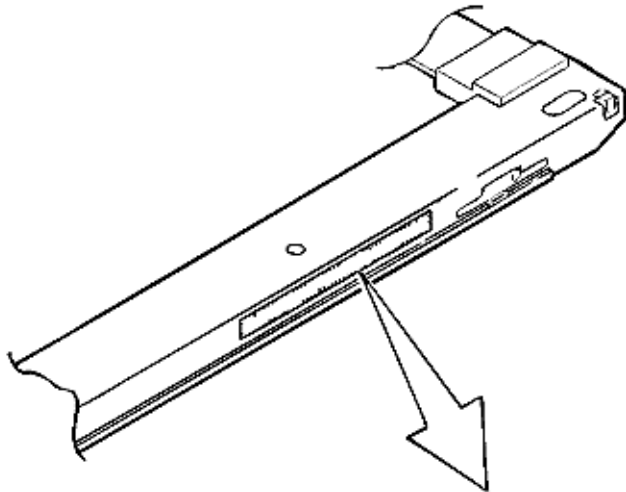
##### **4.2.2 Color Registration Adjustment**



#### 4.2.1 Confirm the LED head driving time

**Note:** When a new LED HEAD is installed, the printer, reads the contents of the EEPROM within the LED HEAD, automatically re-setting the drive time. Therefore, the re-setting of drive time is not necessary. A confirmation of the drive time re-reset is necessary.

- Display of illumination level of the LED head



The trailing three digits of this number indicates the illumination level of the LED head.

Parameter value (displayed on LCD)	Illumination level of LED head	Parameter value (displayed on LCD)	Illumination level of LED head
1	155	17	53 - 57
2	145 - 154	18	50 - 52
3	136 - 144	19	47 - 49
4	127 - 135	20	44 - 46
5	119 - 126	21	41 - 43
6	111 - 118	22	38 - 40
7	104 - 110	23	36 - 37
8	97 - 103	24	33 - 35
9	91 - 96	25	31 - 32
10	85 - 90	26	29 - 30
11	80 - 84	27	27 - 28
12	74 - 79	28	26 - 26
13	70 - 73	29	25 - 25
14	65 - 69	30	22 - 24
15	61 - 64	31	21 - 21
16	58 - 60	32	20



---

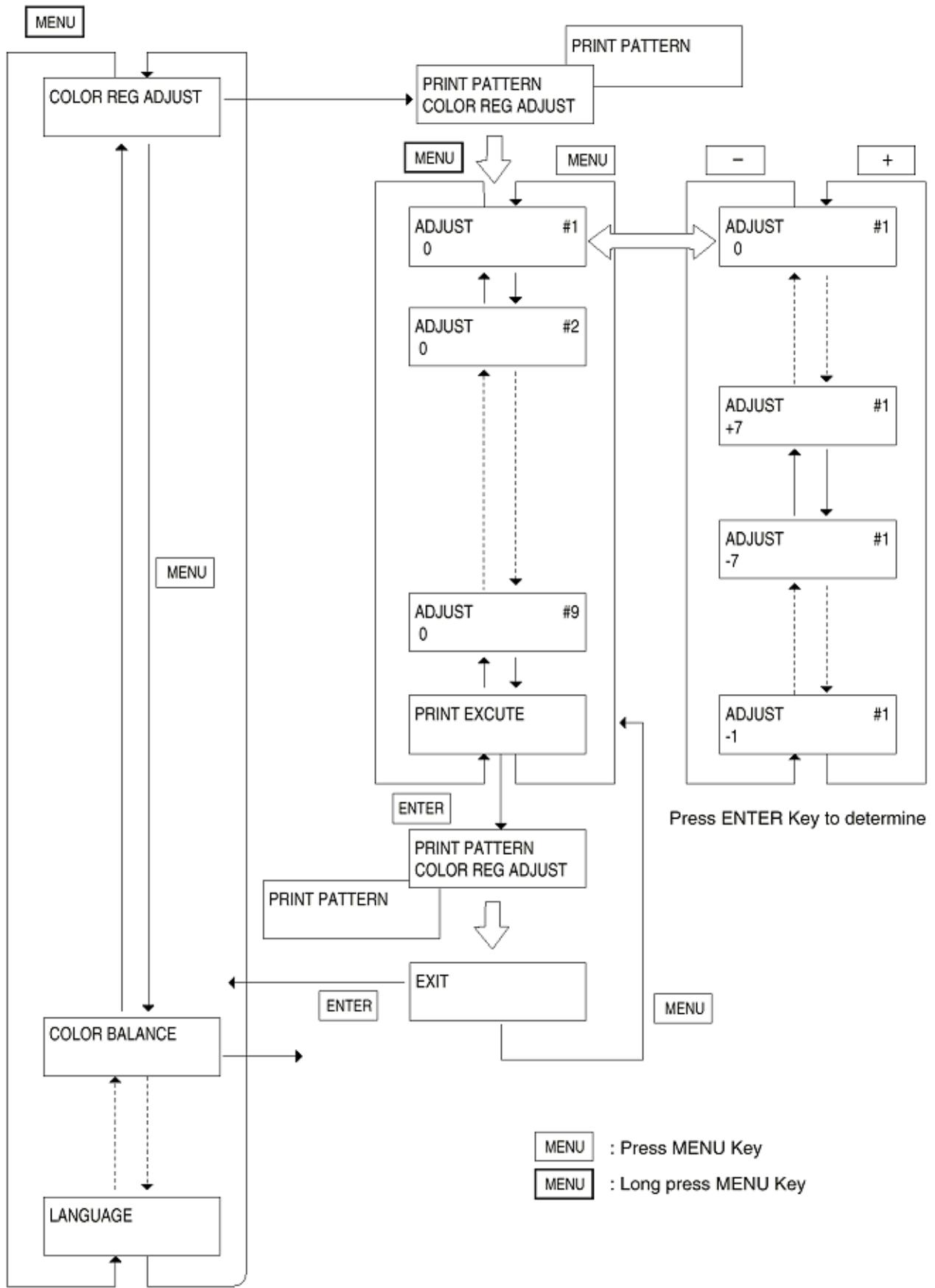
#### **4.2.2 Color Registration Using the Operator Panel (Color deviation correction)**

After replacing a part of the page printer, be sure to check whether colors are matched. If not, correct the deviations.


- Method of correcting color deviations

- (a) Enter Menu 2 mode, select the Color Deviation Correction mode (COLOR REG ADJUST EXECUTE), and print out a color chart (PRINT PATTERN).
- (b) Watch the printed color and check color deviations (#1 to #3 for yellow, #4 to #6 for magenta, and #7 to #9 for cyan).
- (c) After a color chart is printed out, the menu shows the ADJUST #1 mode for entering a correction value for the left (#1) yellow chart.
- (d) Enter correction values for #1 (left yellow chart), #2 (middle yellow chart) and #3 (right yellow chart). Similarly enter correction values for #4 to #6 for left, middle, and center magenta charts and for #7 to #9 for left, middle, and center cyan charts.
- (e) After entering all correction values, print out a new color chart (by PRINT EXECUTE), and check color deviation.
- (f) Repeat the above steps until all colors match.
- (g) Press the ONLINE switch to exit the color correction mode (by EXIT). Initialize the page printer and enter the operation mode.

The menus for correction of color deviations are as follows:




#1



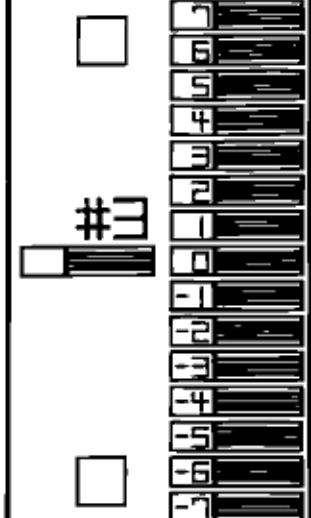
Barcode for #1 with a thick bar at the 0 position.

#2




Barcode for #2 with a thick bar at the 0 position.

#3




Barcode for #3 with a thick bar at the 0 position.

#4



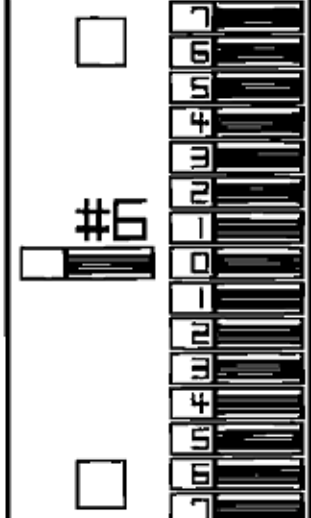
Barcode for #4 with a thick bar at the 0 position.

#5




Barcode for #5 with a thick bar at the 0 position.

#6



Barcode for #6 with a thick bar at the 0 position.

#7



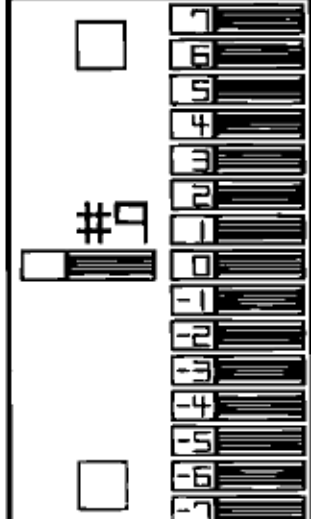
Barcode for #7 with a thick bar at the 0 position.

#8



Barcode for #8 with a thick bar at the 0 position.

#9



Barcode for #9 with a thick bar at the 0 position.

***Color Check pattern***

---

Copyright 1999, Okidata, Division of OKI America, Inc. All rights reserved.



---

**Periodic Maintenance**

**5.1 Periodically Replaced Parts**

**5.2 Cleaning**

**5.3 Cleaning the LED Lens Array**

**5.4 Cleaning the Pickup Roller**





### 5.1 Periodically Replaced Parts

The parts listed below should be replaced periodically. If the parts are not replaced, output quality may be poor, in extreme cases, the printer may malfunction.

Parts Name	Display of warning condition	Recommend condition for replacement	Adjustment after replacement
Toner Cartridge	When the "TONER LOW" message is displayed	When 3,000 pages are printed out (5% print density) (without the first cartridge)	Replace Toner Cartridge
Image Drum Unit	When the "CHG DRUM" message is displayed	When 12,000 pages are printed out	Reset the drum counter of the replaced drum
Oil Roller Assy	When the "OIL ROLLER LIFE" message is displayed	When 10,000 pages are printed out	Replace Holder Assy Oil Roller
Waste toner bottle	When the "WASTE TONER FULL" message is displayed	When 25,000 pages are printed out (single images of 5% print density)	Replace Waste Toner Bottle and Oil Roller
Fuser Unit (Heat Unit Assy)	When the "FUSER LIFE" message is displayed	When 60,000 pages are printed out	Reset the fuser counter
Transfer Belt	When the "BELT LIFE" message is displayed	When 50,000 pages are printed out	Reset the belt counter

The above parts may be replaced by the user.



---

### **5.2 Cleaning**

Periodically clean the inside and outside of the page printer with a soft cloth and small vacuum cleaner. The vacuum cleaner must have a toner-safe filter.

**Caution:** Do not touch the terminals of the image drums, the LED lens array, or the LED head connector block.



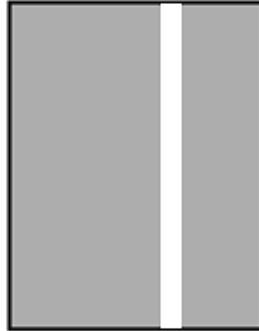
---

### 5.3 Cleaning the LED Lens Array

The LED lens array must be cleaned when the printed paper has white lines or irregular colors (void, light printing) along vertically down of the paper.

**CAUTION:** Always use the LED head cleaner to clean the LED lens array. (The LED head cleaner always comes with the toner cartridge.)

White line or irregular color (void, light printing)





---

#### **5.4 Cleaning the Pickup Roller**

When lines along the length are developed, clean up Pickup Roller.

**(Note:)** Clean it up with a soft cloth and the like so that the surface is not scratched.



---

**6.0 Troubleshooting Procedures**

**6.1 Troubleshooting Tips**

**6.2 Points to Check before Correcting Image Problems**

**6.3 Tips for Correcting Image Problems**

**6.4 Preparation for Troubleshooting**

**6.5 Troubleshooting Charts**



---

## 6.1 Troubleshooting Tips

1. Check the basic check points covered in the user's manual.
2. Gather as much information on the problem from the customer as possible.
3. Perform inspections in conditions close to those in which the problem occurred.



---

## 6.2 Points to Check before Correcting Image Problems

1. Is the printer being run in proper ambient conditions?
2. Have the supplies (toner) and the routine replacement part (image drum cartridge) been replaced properly?
3. Does the paper meet specifications? See paper specifications section.
4. Has the image drum cartridge been installed properly?



---

### 6.3 Tips for Correcting Image Problems

1. Do not touch, or bring foreign matter into contact with the surface of the image drum.
2. Do not expose the image drum to direct sunlight.
3. Keep hands off the fuser unit as it is heated during operation.
4. Do not expose the image drum to light for longer than 5 minutes at room temperature.





---

**6.4 Preparation for Troubleshooting**  
**(1) Operator panel display**

The error messages for this printer are displayed on the liquid crystal display (LCD) in the operator panel. Take proper corrective action as directed by messages that are displayed on the LCD.



---

### **6.5 Troubleshooting Flow**

If problems should develop in this printer, troubleshoot using the following flowchart.

#### **6.5.1 LCD status message/problem list**

#### **6.5.2 LCD message troubleshooting**

#### **6.5.3 Image troubleshooting**

---

Copyright 1999, Okidata, Division of OKI America, Inc. All rights reserved.



**6.5.1 LCD status message/trouble list**

Table 6-1 lists the status and problems that may be indicated by messages on the LCD.

xxx: Emulation in operation (AUT, PCL, PS)

ffff: Trays (Tray1, Tray2, Front)

mmmmmm: Paper Size (Letter, A4, etc...)

**Table 6.1**

Category	LCD Status Message	LED K	LED C	LED M	LED Y	READY	ATTENTION	Trouble or Status	Remedy
<b>Daily status</b>	TNR SNS *****	ON	ON	ON	ON	Undefined	ON	Indicates	
	FRONT TRAY ERROR PRESS RECOVERKEY	Undefined	Undefined	Undefined	Undefined	OFF	Blink	Indicates that the front feeder has caused a home position error.	The front feeder becomes not available when the RECOVER switch is pressed. The other tray is available. This message is cleared when the front feeder assembly is replaced.
<b>Buffer Overflow</b>	ERROR MEMORY OVERFLOW	Undefined	Undefined	Undefined	OFF	OFF	Blink	Indicates that data overflowed the memory space. - Too much print data in one page - Too much macro data - Too much DLL data - Data overflow after compression of frame data	This error corrected when the RECOVER switch is pressed.  Expand RAM or reduce data.
	ERROR RECEIVE BUFFER	Undefined	Undefined	Undefined	Undefined	OFF	Blink	Indicates that the receive buffer overflowed.	This error is corrected when the RECOVER switch is pressed.  Increase the setting of Receive Buffer Size (in User Maintenance Mode), then send the data from the host or expand RAM.
<b>Paper Size Error</b>	ERROR PAPER SIZE CHECK tttttt	Undefined	Undefined	Undefined	Undefined	OFF	Blink	Indicates that paper of the illegal size was fed from the specified tray. ttttt Tray type (Tray 1, Tray 2, or Front)	Check the size of paper in the tray or whether two or more paper sheets are fed at a time.  When the cover is opened and closed, this error is reset and printing resumes. If this error occurs frequently, go to 6.5.2.

<b>Paper Jam Error</b>	PAPER INPUT JAM CHECK ttttt	Undefined	Undefined	Undefined	Undefined	OFF	Blink	Indicates that a paper jam occurred on the paper feeding from the specified tray. ttttt Tray type (Tray 1, Tray 2, or Front)	Check the size of paper in the tray or whether two or more paper sheets were fed a time. When the cover is opened and closed, this error is reset and printing resumes. If the error occurs frequently, go to 6.5.2.
<b>Paper Jam Error</b>	PAPER FEED JAM CHECK ttttt	Undefined	Undefined	Undefined	Undefined	OFF	Blink	Indicates that a paper coming out of the tray jammed on the paper traveling printer. ttttt Tray type (Tray 1, Tray 2, or Front)	Check the size of paper in the tray or whether two or more paper sheets were fed a time. When the cover is opened and closed, this error is reset and printing resumes. If this error occurs frequently, go to 6.5.2.
<b>Paper Jam Error</b>	PAPER FEED JAM CHECK ttttt	Undefined	Undefined	Undefined	Undefined	Off	Blink	Indicates that a paper coming out of the tray jammed on the paper traveling printer. ttttt Tray type (Tray 1, Tray 2, or Front)	Check the size of paper in the tray or whether two or more paper sheets were fed a time. When the cover is opened and closed, this error is reset and printing resumes. If this error occurs frequently, go to 6.5.2.
	PAPER EXIT JAM REMOVE THE PAPER	Undefined	Undefined	Undefined	Undefined	OFF	Blink	Indicates that a paper jammed on the way to the exit.	Open the cover and remove a paper jam from the inside of the page printer. When the cover is opened and closed, this error is reset and printing resumes. If this error occurs frequently, go to 6.5.2.
<b>Controller Error</b>	EEPROM RESETTING	Undefined	Undefined	Undefined	Undefined	OFF	Blink	Indicates that the ID number of EEPROM is invalid.	Set the default values in EEPROM and it'll be recovered automatically.

**Category: Controller Error (continued) - Table 6.1**

LCD Status Message	LED K	LED C	LED M	LED Y	READY	ATTENTION	Code (nn)	Trouble or Status	Remedy
								Details of error	Remedy



### 6.5.2 LCD message troubleshooting


If a problem cannot be repaired according to the LCD message problem list, troubleshoot using the troubleshooting chart.

No.	Trouble	Flowchart Number
1	The printer does not work normally after being turned on.	(1)
2	JAM Error Paper Input Jam (1st Tray) Paper Input Jam (Front Feeder) Paper Feed Jam Paper Exit Jam 2-4	(2) -1 (2) -2 (2) -3 (2) -4
3	Paper Size Error	(3)
4	Image Drum Unit Up/Down Error	(4)
5	Fusing Unit Error	(5)
6	Fan Motor Error	(6)
7	Cannot receive data from parallel interface	(7)

**Note:** When replacing the main board (PCE PCB) and the engine board (PX4 PCB), remove EEPROM chips from the old boards and install them on the new boards.



**(1) The printer does not work normally after turned on.**

- Turn off the power of the printer, wait a few seconds, then turn on power again.
- Is  displayed on the LCD (for about 1 second)?
  - No Is the AC cable connected correctly?
    - No Connect the AC cable correctly.
  - Yes Does a voltage of +5V are being supplied on the panel connector of the main board (PCE PCB)?  
Pin 5: +5V Pin 2: 0V
    - Yes Is the operator panel cable connected correctly?
      - No Connect the cable correctly.
      - Yes Replace the operator panel cable. Recovered?
        - No Replace the cover assembly operator panel.
        - Yes End
    - No Check the connection of the PU connector. Does a voltage of +5V are being supplied on the PU connector of the main board (PCE PCB)?  
Pin 6, 15, 26, 35: +5V Pin 1, 3, 5, 11, 20, 21, 40: 0V
      - Yes Replace the main board.
    - No Does a voltage of +5V are being supplied on the Power connector of the engine board (PX4 PCB)?  
Pin 11,12, 13, 14: +5V Pin 3, 4, 5, 6, 23, 24, 5, 26, 27, 28, 29, 30: 0V
      - No Check the connection of the power connector or replace the low-voltage power supply unit.
      - Yes Replace the engine board.
    - Yes Do the following voltages are being supplied on the PU connector of the main board?  
Pin 6, 15, 26, 35: +5V Pin 2, 22: +3.3V  
Pin 23: -12V Pin 25: +12V Pin 1, 3, 5, 11, 20, 21, 40: 0V
      - Yes Replace the main board.
    - No Do the following voltages are being supplied on the power connector of the engine board?  
Pin 11, 12, 13, 14: +5V Pin 15, 16, 17, 18: +3.3V  
Pin 1: +12V Pin 2: -12V Pin 7, 8, 9, 10: +32V  
Pin 3, 4, 5, 6, 23, 24, 25, 26, 27, 28, 29, 30: 0V
      - Yes Replace the engine board.
    - No Replace the low-voltage power supply unit.





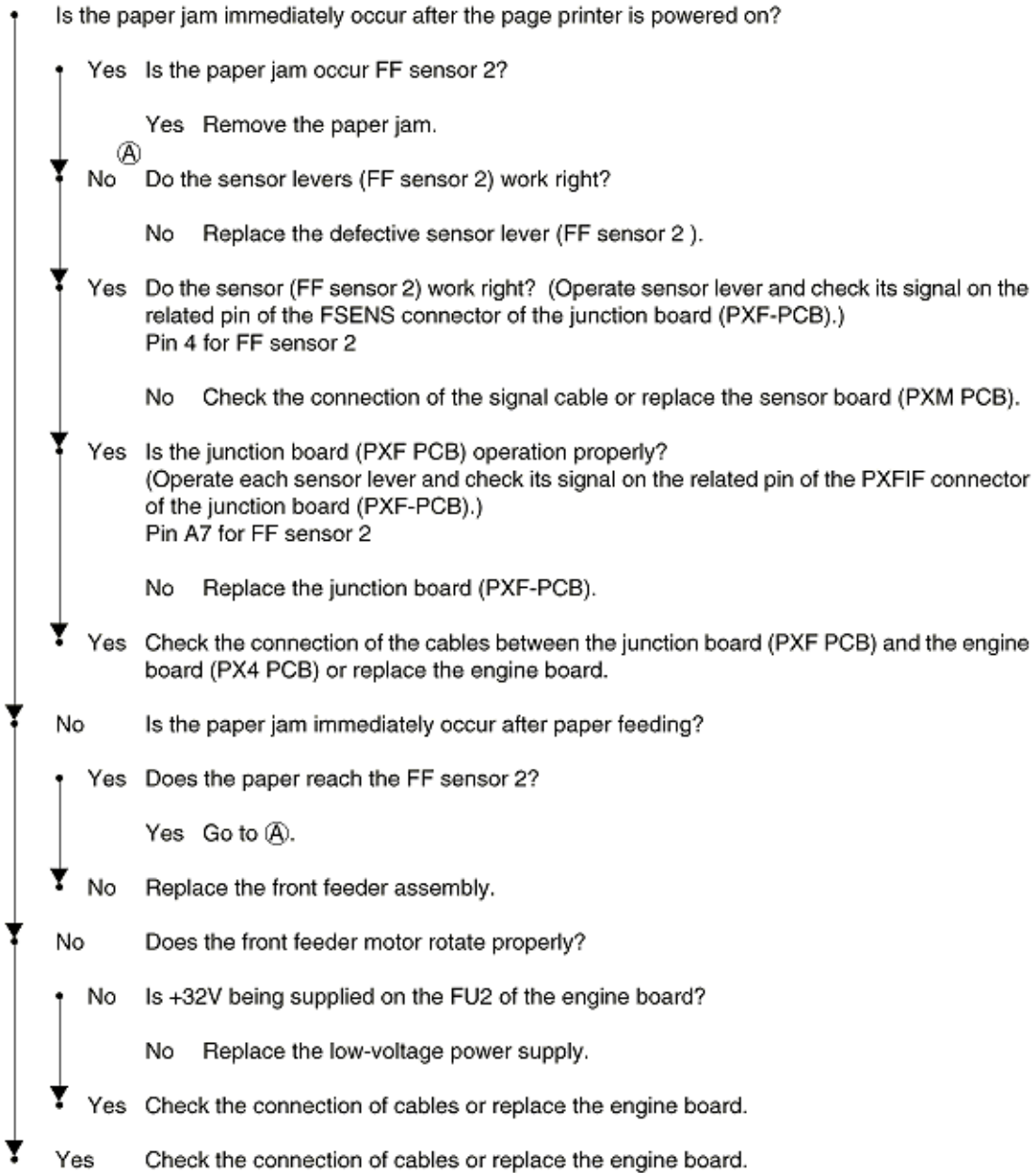
## (2) JAM ERROR

### ②-1 Paper input jam (1st tray)

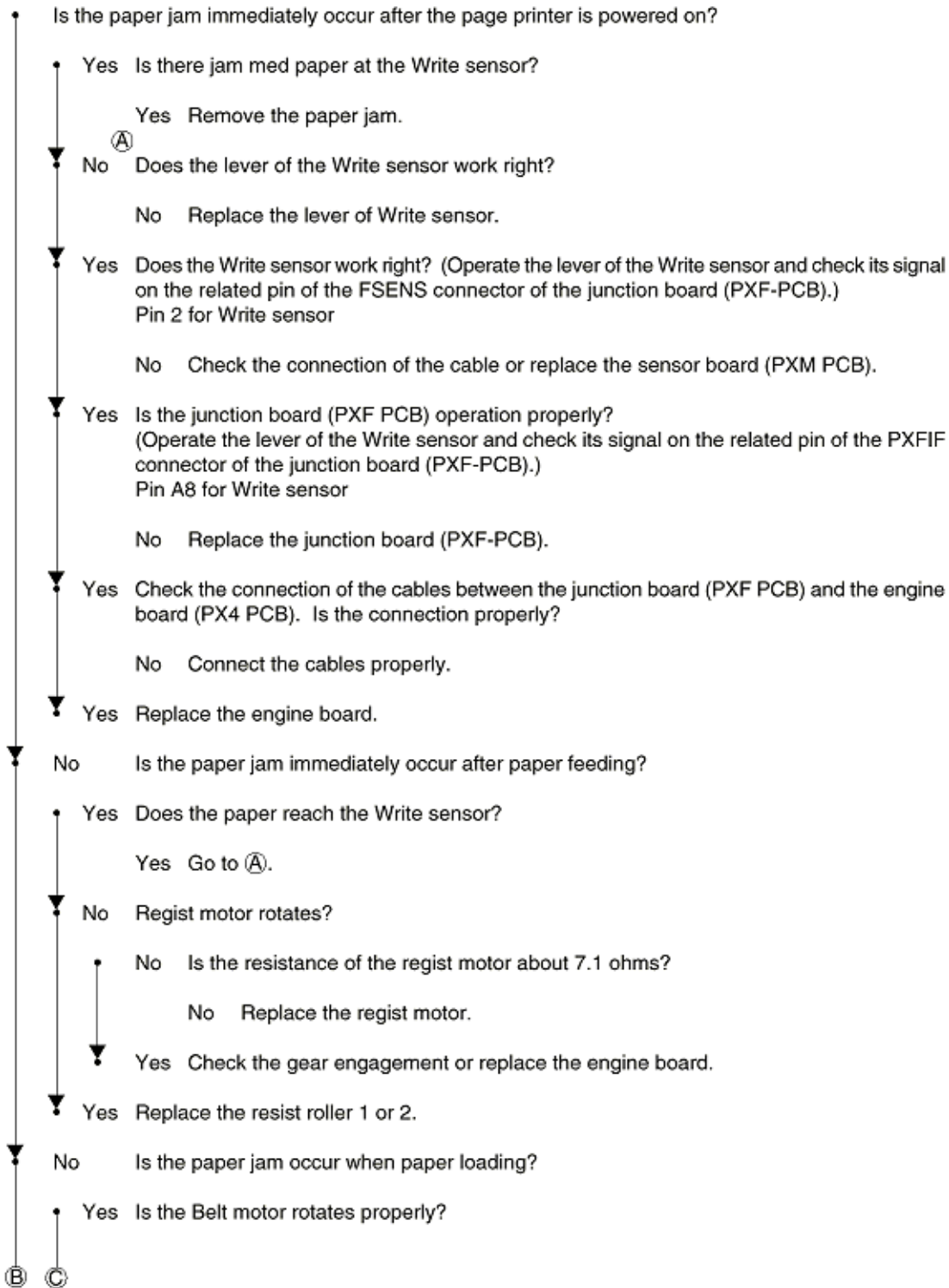
- Does the paper reach the FF sensor 1 or 2?
  - Yes Remove the paper jam.
    - Do the sensor levers (FF sensor 1, FF sensor 2) work right?
      - No Replace the defective sensor lever (FF sensor 1, FF sensor 2).
  - ▼ Yes Do the sensors (FF sensor 1, FF sensor 2) work right? (Operate each sensor lever and check its signal on the related pin of the FSENS connector of the junction board (PXF-PCB).) Pin 1 for FF sensor 1, Pin 4 for FF sensor 2
    - No Check the connection of the signal cable or replace the sensor board (PXM PCB).
  - ▼ Yes Is the junction board (PXF PCB) operation properly? (Operate each sensor lever and check its signal on the related pin of the PXFIF connector of the junction board (PXF-PCB).) Pin B8 for FF sensor 1, Pin A7 for FF sensor 2
    - No Replace the junction board (PXF-PCB).
  - ▼ Yes Check the connection of the connectors between the junction board (PXF PCB) and the engine board (PX4 PCB) or replace the engine board.
  - ▼ No Replace the feed roller or the paper separation frame assembly of the paper cassette.
- Is the regist motor rotates properly?
  - Yes Replace the feed roller or the paper separation frame assembly of the paper cassette.
  - ▼ No Is the resistance of the regist motor about 7.1 ohms?
    - No Replace the regist motor.
  - ▼ Yes Is +32V being supplied on the FU2 of the engine board?
    - No Replace the low-voltage power supply.
  - ▼ Yes Check the gear engagement and the connection of the cables or replace the engine board.

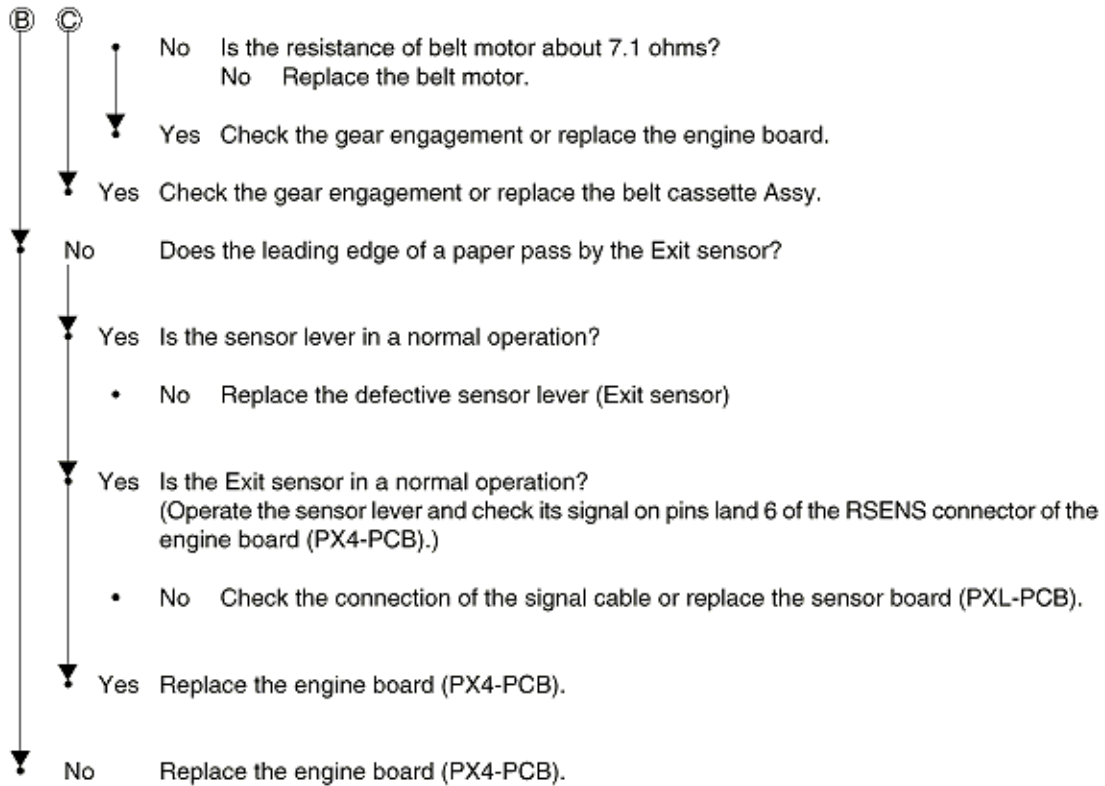


②-2 Paper input jam (Front feeder)

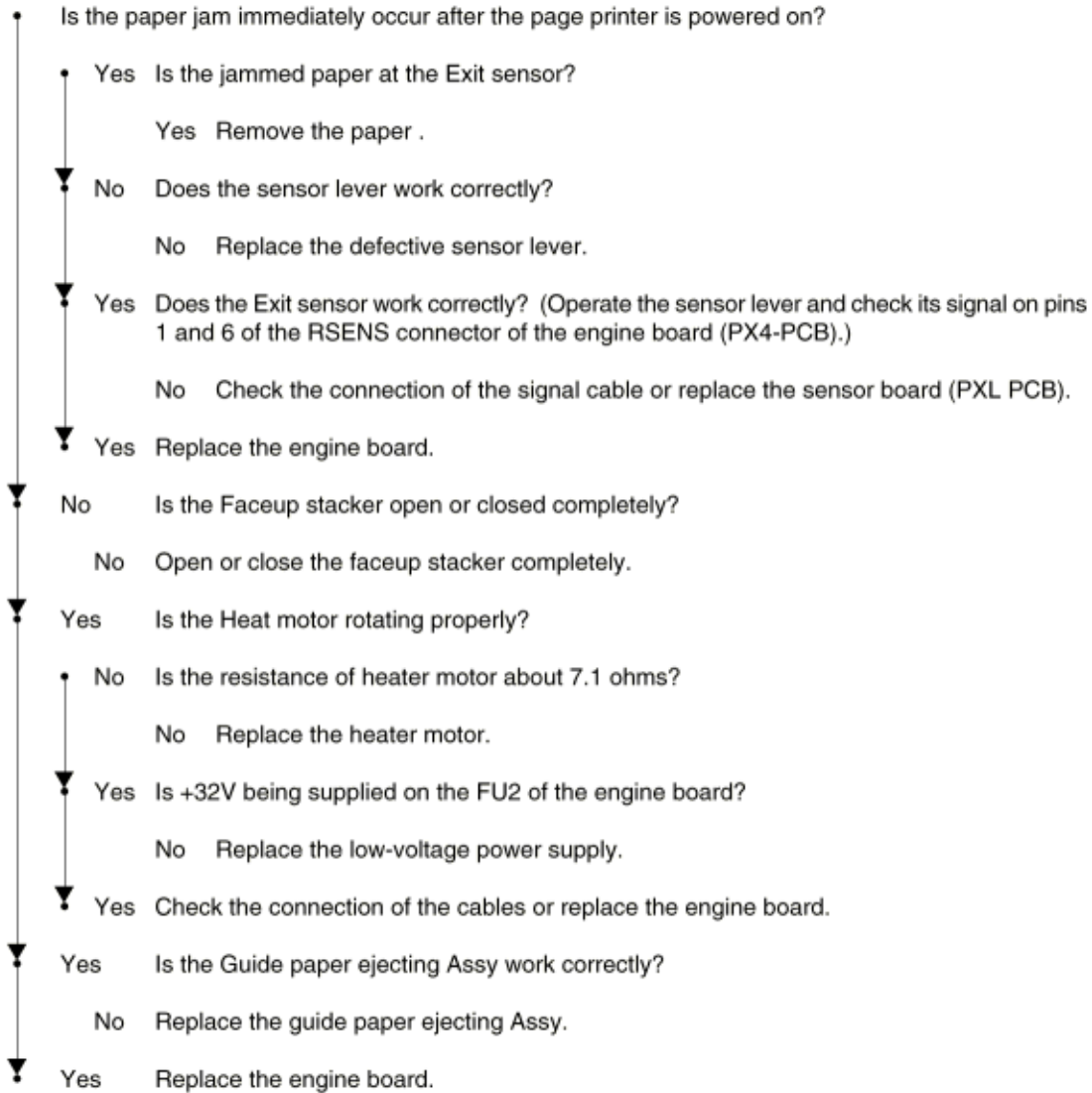


②-3 Paper feed jam





②-4 Paper Exit Jam





**(3) Paper Size Error**

- Is the paper which being used under the specification?
  - No Use paper which is under the specification.
  - Yes Is the paper jam med at the Lever regist sensor or the Write sensor?
    - Yes Remove the paper.
- ▼ Yes Does the sensor levers (Lever regist sensor ) work correctly?
  - No Replace the defective sensor lever (Lever regist sensor).
- ▼ Yes Does the sensor (Lever regist sensor) work correctly? (Operate each sensor lever and check its signal on the related pin of the FSENS connector of the junction board (PXF-PCB). Pin 4 for Lever regist sensor)
  - No Check the connection of the cables or replace the sensor board (PXM-PCB).
- ▼ Yes Does the Write sensor lever work correctly?
  - No Replace the Write sensor lever.
- ▼ Yes Does the Write sensor work correctly? (Operate the sensor lever and check its signal on the related pin of the FSENS connector of the junction board (PXF-PCB).) Pin 2 for Write sensor)
  - No Check the connection of the cables or replace the sensor board (PXM PCB).
- ▼ Yes Is the Junction board (PXF PCB) work correctly? (Operate the Write sensor lever and check its signal on the related pin of the PXFIF connector of the junction board (PXF-PCB).) Pin A8 for Write sensor)
  - No Replace the junction board (PXF-PCB).
- ▼ Yes Check the connection of the cables between the junction board (PXF PCB) and the engine board (PX4 PCB) or replace the engine board. Connection correctly?
  - No Connect the cables correctly.
- ▼ Yes Replace the engine board.



---

**(4) Image Drum Unit (IDU) Up/Down Error**

- Turn off power to the page printer, wait a few seconds, then turn on power again.
- Each image drum unit (IDU) motor rotating for printout?
  - No Is the value of IDU motor resistance about 7.1 ohms?
    - No Replace the defective IDU motor.
  - ▼ Yes Is +32V being supplied on the FU2 of the engine board?
    - No Replace the low-voltage power supply.
  - ▼ Yes Check the connection of the cables or replace the engine board.
- ▼ Yes Each IDU sensor lever work correctly?
  - No Check the gear engagement and the sensor lever operation or replace the gear or the sensor lever.
- ▼ Yes Is each IDU sensor work correctly?  
(Cover up for each IDU sensor to shut off light and check its signal on the related pin of the PXFI connector of the junction board (PXF PCB).)  
Pin B13 for the yellow IDU sensor Pin A13 for the magenta IDU sensor Pin B14 for the cyan IDU sensor Pin A14 for the black IDU sensor
  - No Replace the junction board (PXF PCB).
- ▼ Yes Check the connection of the cables between the junction board (PXF PCB) and the engine board (PX4 PCB) or replace the engine board.



**(5) Fusing Unit Error**

- Is the Fusing unit trouble occur immediately after the page printer is powered on?
  - Yes Is Heat roller thermistor open or shorted? (See Figure 6.1.)  
(Normal resistance and temperature are about between 90 ohms the 700 ohms at room temperature between 0°C the 43°C)
    - Yes Is the voltage being supplied on pin 8 of the THERM connector of the engine board (PX4 PCB)?  
Normaly Voltage: between 0.03V and 0.25V
      - Yes Replace the engine board.
    - No Replace the fusing unit.
  - No Is Backup roller thermistor open or shorted? (See Figure 6.1.)  
(about 90 ohms to 700 ohms at room temperature 0°C to 43°C)
    - Yes Is the voltage being supplied on Pin4 of the THERM connector of the engine board (PX4 PCB) normal?  
Normaly Voltage: between 0.03V and 0.25V
      - No Replace the engine board.
    - Yes Replace the fusing unit.
- No
- No Is Fusing unit trouble occur about 3 minutes elapsed after the page printer is powered on?
  - No Go to (A).
  - Yes Is Fusing unit heater turn on? (Is the heater hot?)
    - Yes Is the voltage being supplied on pin 6 of the THERM connector of the engine board (PX4 PCB) normal?  
Rated voltage: 0.03V to 0.25V
      - Yes Replace the engine board.
    - No Replace the fusing unit.
  - No Is AC voltage appears between pins 1 and 3 of the CN1 connector of the low-voltage power supply?
    - No Replace the low-voltage power supply.
    - Yes Replace the fusing unit.

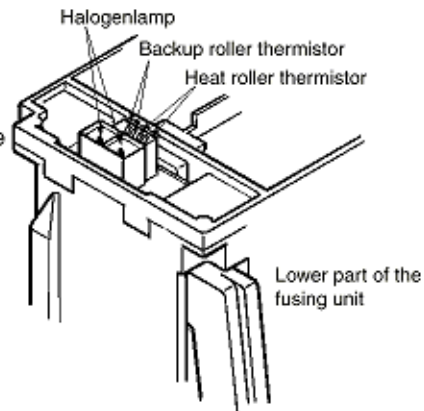


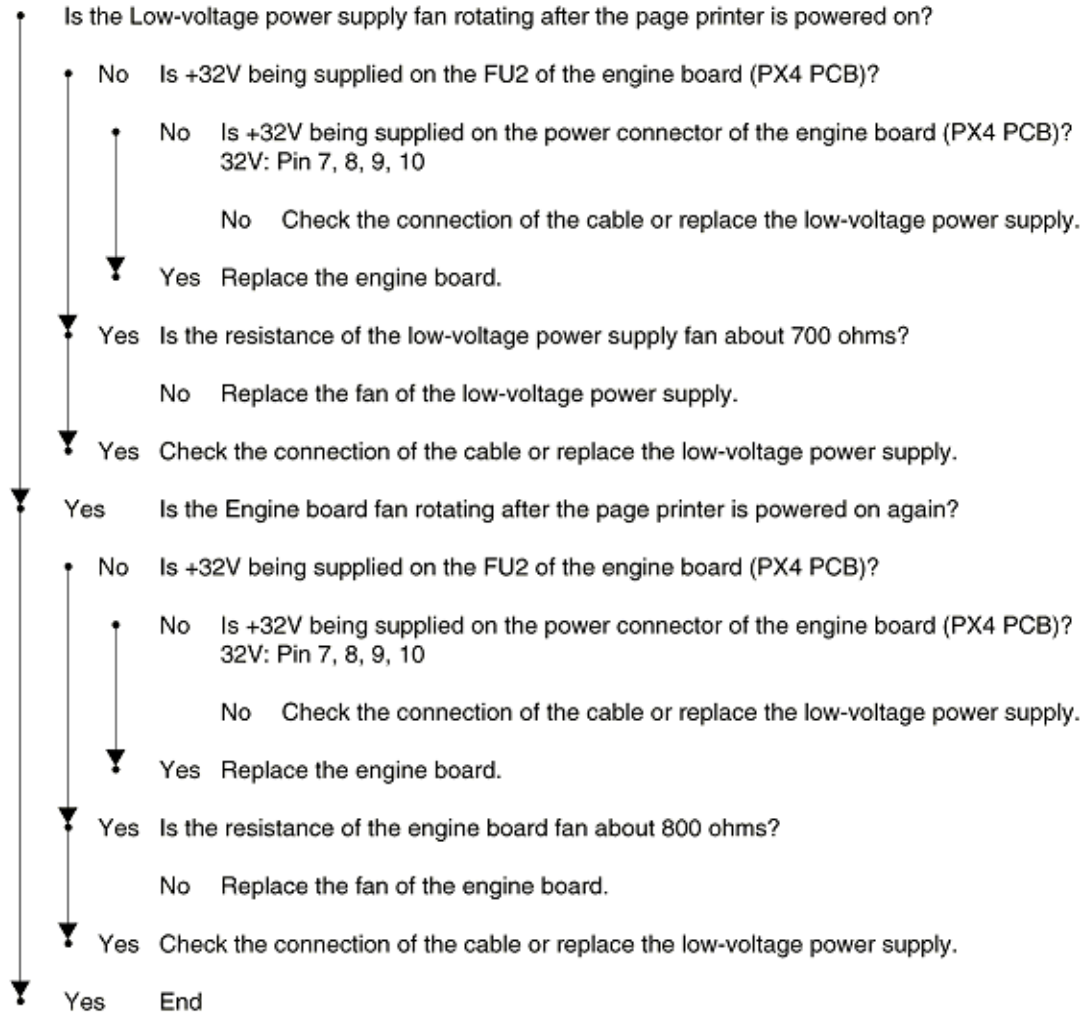
Figure 6.1







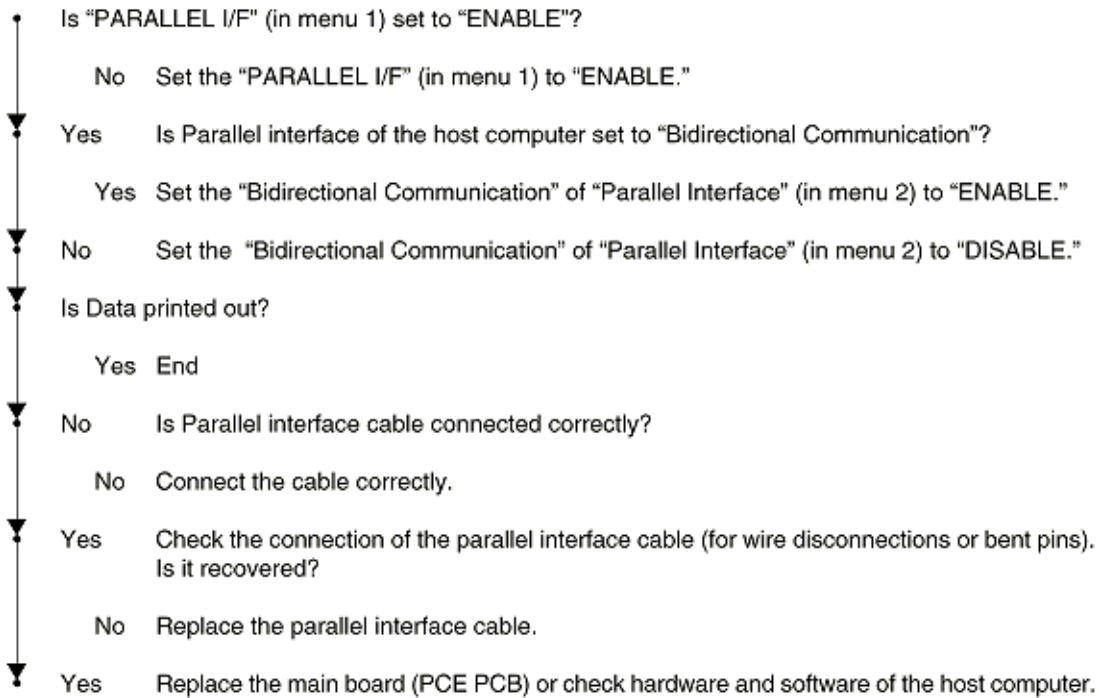
**(6) Fan Motor Error**





---

**(7) Cannot Receive Data from Parallel Interface**





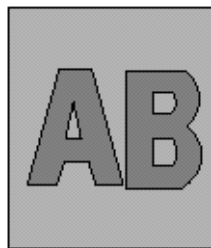
**6.5.3 Image Troubleshooting**

When the printout images are not satisfactory, follow the troubleshooting steps listed below.

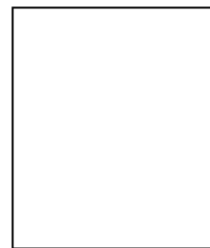
Printout problem	Reference flowchart No.
Light or blurred images (Figure 6.2-A)	(1)
Dark background (Figure 6.2-B)	(2)
Blank paper (Figure 6.2-C)	(3)
Vertical black (Figure 6.2-D)	(4)
Vertical white (Figure 6.2-F)	(5)
Poor fusing (Images are blurred or peeled off when touched)	(6)
Evenly spaced, repeating marks (Figure 6.2-E)	(7)
Missing characters or colors	(8)
Poor synthesization Color	(9)
Printout colors different from original colors	(10)



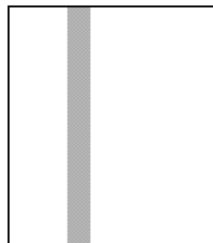
(A) Light or blurred images as a whole



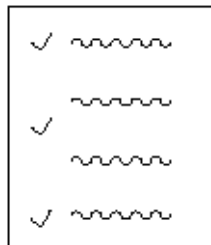
(B) Dark background density



(C) Blank paper



(D) Black stripes in the vertical direction



(E) Cyclical defect



(F) White belts or streaks in the vertical direction



---

(1) Light or blurred images on the whole printout area

- Is toner low? ("TONER LOW" indicator on?)
  - Yes Supply toner.
- ▼ No Specified paper?
  - No Use the specified paper.
- ▼ Yes Is the lens of the LED head dirty?
  - Yes Clean the LED head lens.
- ▼ No Is Each LED head assembly connected correctly to the junction board (PD6 PCB)?
  - No Check the connection of the cables (between each LED head and the junction board) or connect the LED head cables to the junction board correctly.
- ▼ Yes Is +3.3V being supplied on the following pins of the HEADPOW connector of the junction board (PD6 PCB)?  
+3.3V: Pin 1, 2, 3, 4, 5, 6
  - Yes Is +3.3V being supplied to each LED head assembly from the junction board (PD6 PCB)?  
Pins 1, 2, 3, 4, 5, 6 of the YPOW connector for the yellow LED head assembly  
Pins 1, 2, 3, 4, 5, 6 of the MPOW connector for the magenta LED head assembly  
Pins 1, 2, 3, 4, 5, 6 of the CPOW connector for the cyan LED head assembly  
Pins 1, 2, 3, 4, 5, 6 of the BPOW connector for the black LED head assembly
    - No Replace the junction board (PD6 PCB).
  - ▼ Yes Check the connection of the cables or replace the LED head assembly.
- ▼ No Is +3.3V being supplied on the following pins of the HEADPOW connector of the engine board (PX4 PCB)?  
+3.3V: Pin 1, 2, 3, 4, 5, 6
  - Yes Replace the cable.
- ▼ No Is +3.3V being supplied on the following pins of the POWER connector of the engine board (PX4 PCB)?  
+3.3V: Pin 15, 16, 17, 18
  - Yes Replace the engine board.
- ▼ No Check the connection of the cables or replace the low-voltage power supply. Recovered?
  - Yes End
- ▼ No Is +32V being supplied on the power connector of the engine board (PX4 PCB)?  
+32V: Pin 7, 8, 9, 10
  - No Check the connection of the cables or replace the low-voltage power supply.
- ▼ Yes Is +32V being supplied on pin 2 of the HVOLT connector of the engine board (PX4 PCB)?
  - No Replace the engine board.

Ⓐ



Yes Check the connection of the cables, replace the high-voltage power supply, or belt cassette assembly. Recovered?

Yes End



No Is Each terminal of each image drum unit connected correctly to the contact assembly? (See Figure 6.2.)

No Make the terminals be in contact with the contact assembly correctly.



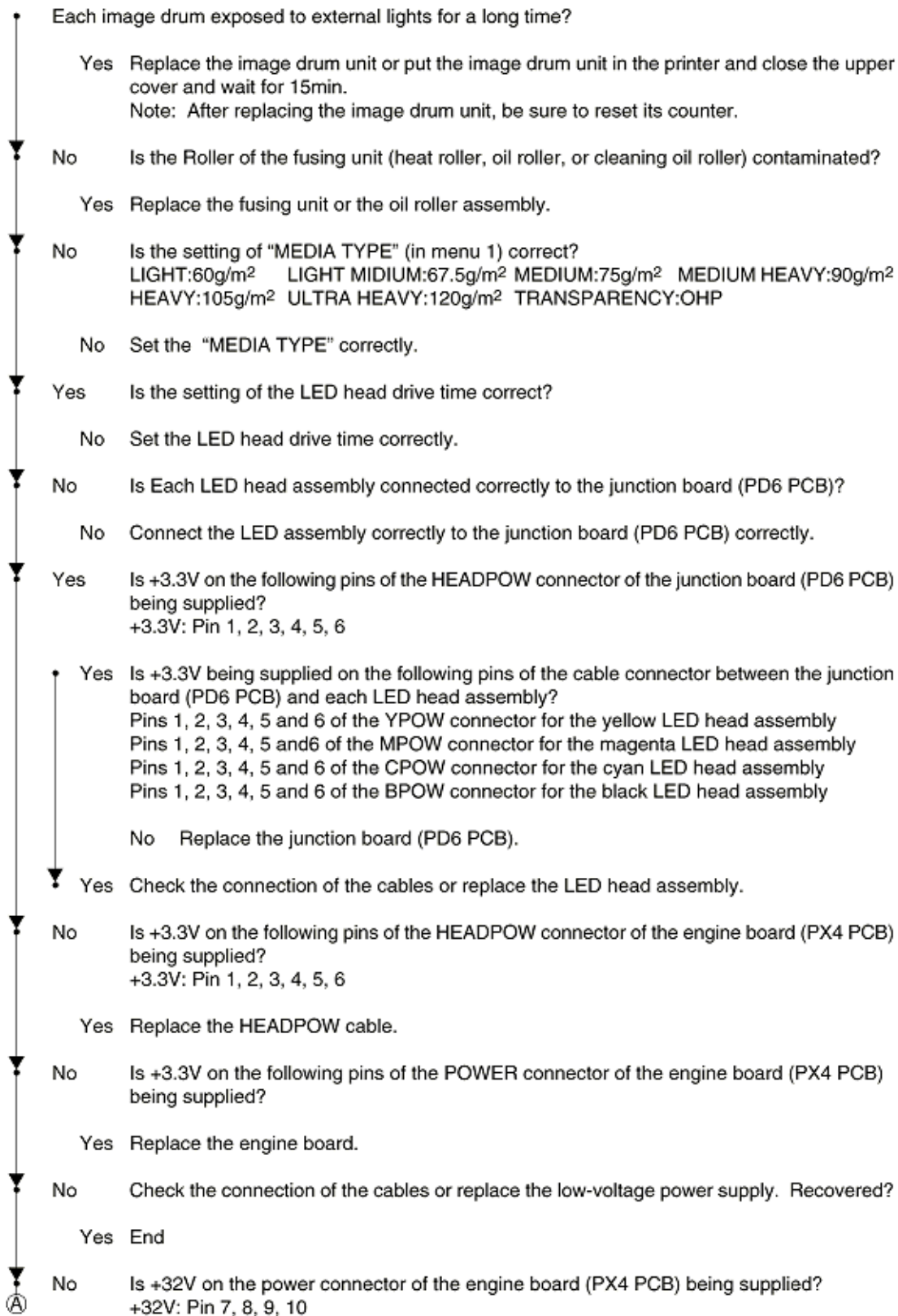
Yes Replace the the image drum unit.

- Notes:
1. When replacing the engine board (PX4 PCB), demount the EEPROM chip from the old engine board and remount it on the new one.
  2. After replacing the image drum unit and the belt cassette assembly, be sure to reset their counters in the User Maintenance mode.
  3. After replacing the LED head assembly, be sure to adjust its drive time and correct its color deviation.



---

(2) Dark background





Ⓐ

No Check the connection of the cables or replace the low-voltage power supply.



Yes Is +32V on pin 2 of the HVOLT connector of the engine board (PX4 PCB) being supplied?

No Replace the engine board.



Yes Check the connection of the cables or replace the high-voltage power supply or belt cassette assembly. Recovered?

Yes End



No Is each terminal of each image drum unit connected to the contact assembly correctly? (See Figure 6.2.)

No Make the terminals be in contact with the contact assembly correctly.

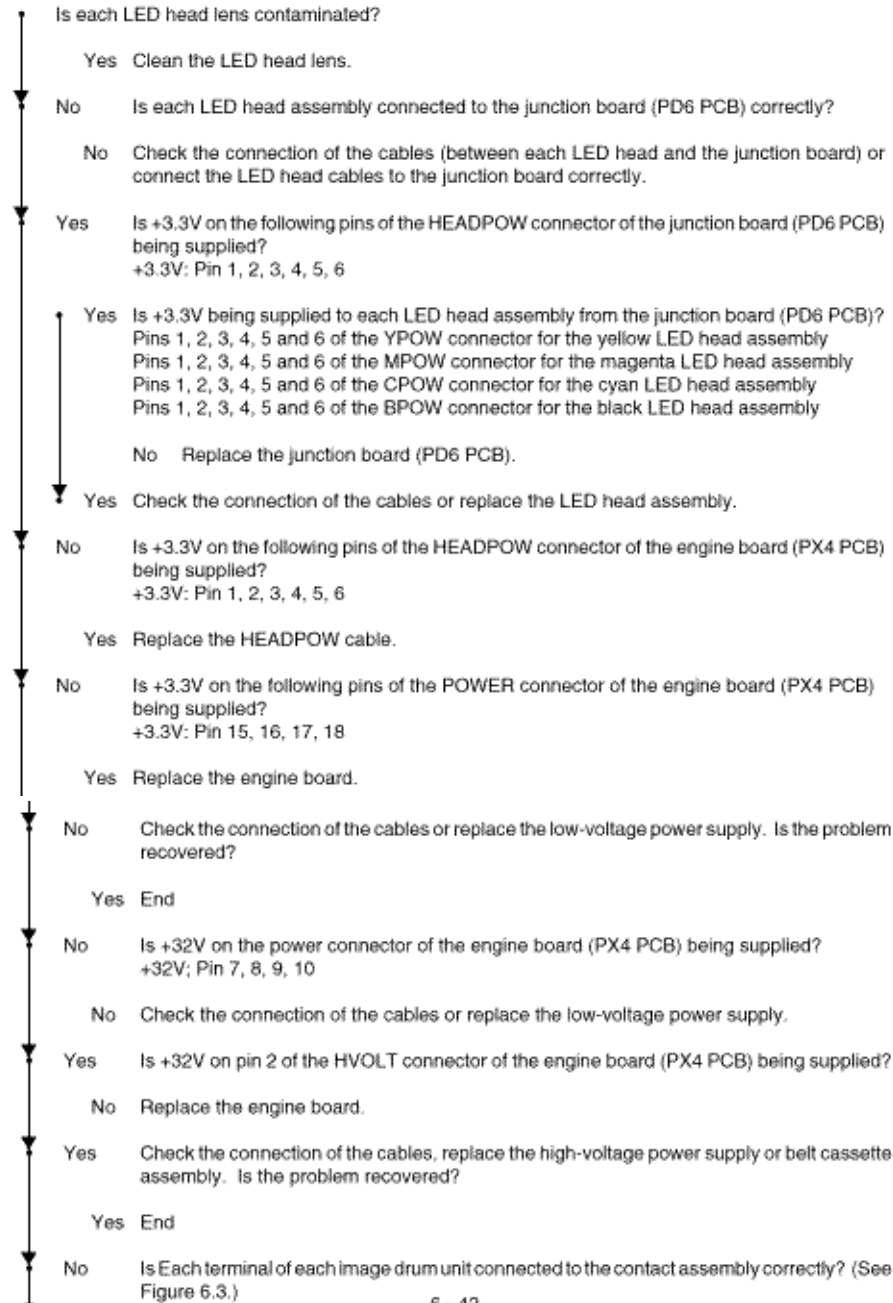


Yes Replace the the image drum unit.

- Notes:
1. When replacing the engine board (PX4 PCB), demount the EEPROM chip from the old engine board and remount it on the new one.
  2. After replacing the image drum unit and the belt cassette assembly, be sure to reset their counters in the User Maintenance mode.
  3. After replacing the LED head assembly, be sure to adjust its drive time and correct its color deviation.



**Printout colors different from original colors**

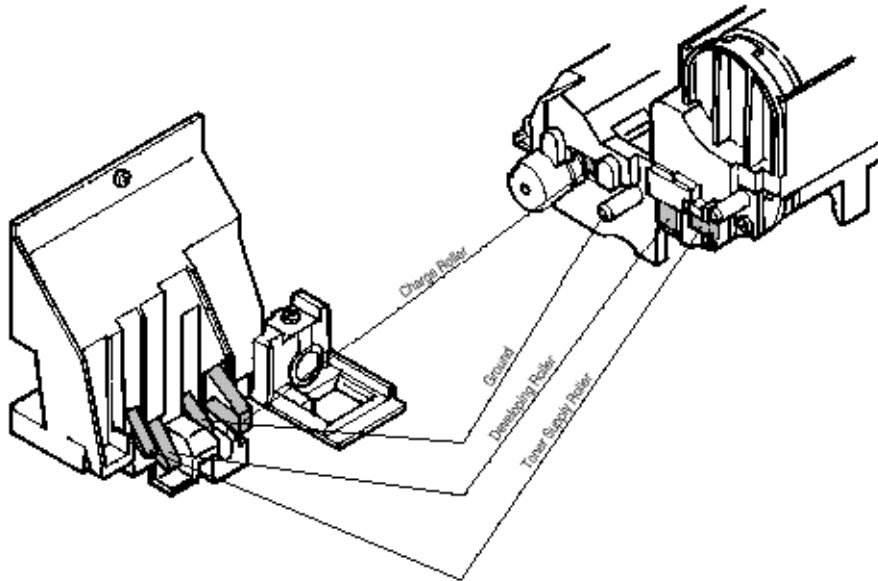




No Make the terminals be in contact with the contact assembly correctly.

Yes Replace the the image drum unit.

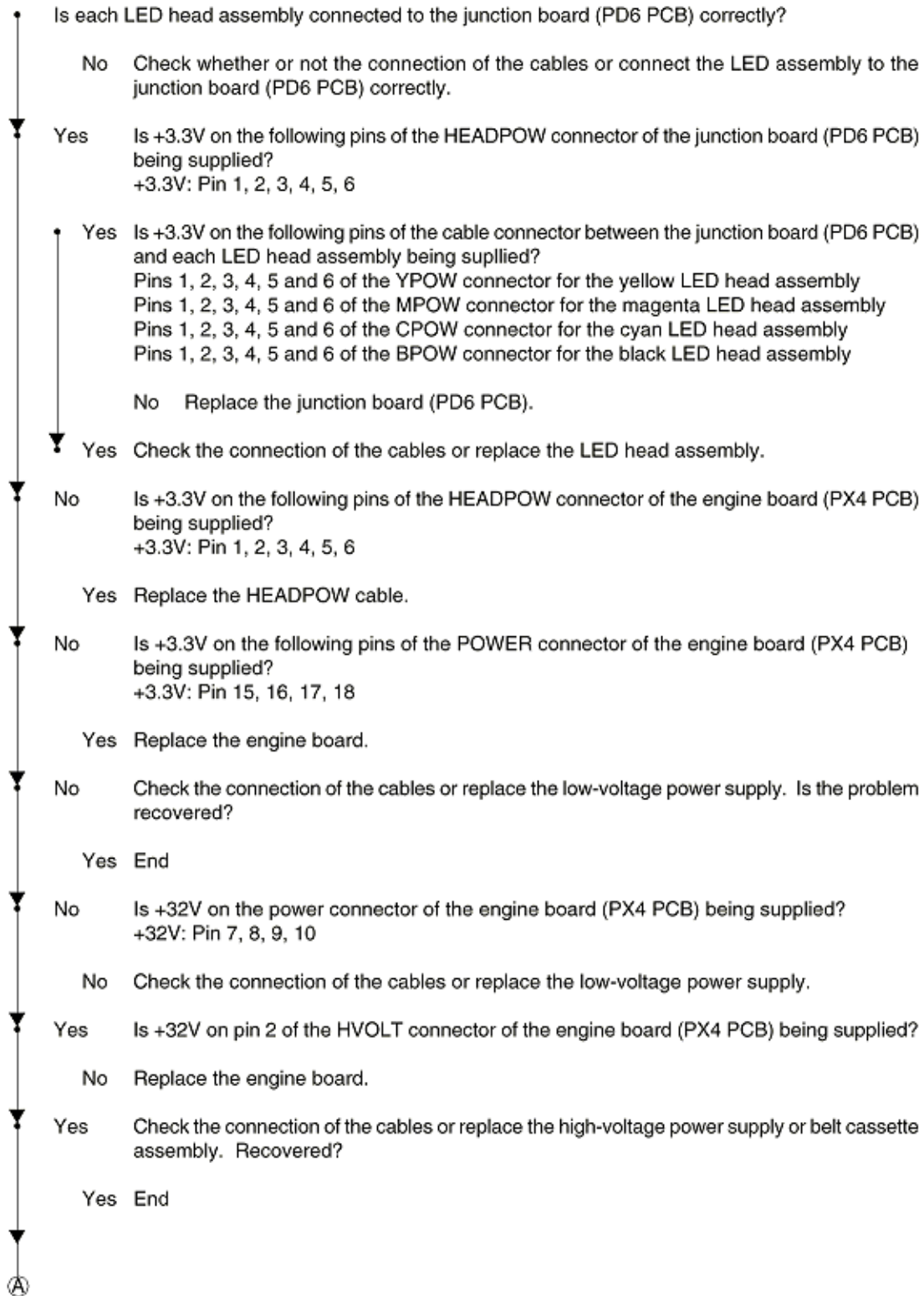
- Notes:
1. When replacing the engine board (PX4 PCB), demount the EEPROM chip from the old engine board and remount it on the new one.
  2. After replacing the image drum unit and the belt cassette assembly, be sure to reset their counters in the User Maintenance mode.
  3. After replacing the LED head assembly, be sure to adjust its drive time and correct its color deviation.





---

**(3) Blank paper**



Ⓐ

- 
- No Is each terminal of each image drum unit connected to the contact assembly correctly? (See Figure 6.2.)
- No Make the terminals be in contact with the contact assembly correctly.
- ▼
- Yes Replace the the image drum unit.

- Notes:
1. When replacing the engine board (PX4 PCB), demount the EEPROM chip from the old engine board and remount it on the new one.
  2. After replacing the image drum unit and the belt cassette assembly, be sure to reset their counters in the User Maintenance mode.
  3. After replacing the LED head assembly, be sure to adjust its drive time and correct its color deviation.



---

**(4) Vertical black (black stripe or lines in the vertical direction)**

- Is each LED head assembly connected to the junction board (PD6 PCB) correctly?
  - No Connect the LED head assembly to the junction board correctly.
  - Yes Check the connection of the cables or replace the LED head assembly. Is the problem recovered?
    - Yes End
- No Check the connection of the cables or replace the junction board (PD6 PCB). Recovered?
  - Yes End
- No Is engine board (PX4 PCB) connected to the junction board (PD6 PCB) correctly?
  - No Connect the engine board to the junction board correctly.
  - Yes Check the connection of the cables or replace the engine board (PX4 PCB). Is the problem recovered?
    - Yes End
- No Is Each terminal of each image drum unit connected to the contact assembly correctly? (See Figure 6.2.)
  - No Make the terminals be in contact with the contact assembly correctly.
  - Yes Replace the the image drum unit.

- Notes:
1. When replacing the engine board (PX4 PCB), demount the EEPROM chip from the old engine board and remount it on the new one.
  2. After replacing the image drum unit, be sure to reset its counter in the User Maintenance mode.
  3. After replacing the LED head assembly, be sure to adjust its drive time and correct its color deviation.



---

**(5) Vertical white (White stripe or lines in the vertical direction)**

- Is each LED head lens contaminated?
  - Yes Clean the LED head lens.
- ▼ No Is each LED head assembly connected to the junction board (PD6 PCB) correctly?
  - No Connect the LED head assembly to the junction board (PD6 PCB) correctly.
- ▼ Yes Check the connection of the cables or replace the LED head assembly. Is the problem recovered?
  - Yes End
- ▼ No Check the connection of the cables or replace the junction board (PD6 PCB). Is the problem recovered?
  - Yes End
- ▼ No Is engine board (PX4 PCB) connected to the junction board correctly?
  - No Connect the boards correctly.
- ▼ Yes Check the connection of the cables or replace the engine board (PX4 PCB). Is the problem recovered?
  - Yes End
- ▼ No Is each terminal of each image drum unit connected to the contact assembly correctly? (See Figure 6.2.)
  - No Make the terminals be in contact with the contact assembly correctly.
- ▼ Yes Replace the the image drum unit.

- Notes:
1. When replacing the engine board (PX4 PCB), demount the EEPROM chip from the old engine board and remount it on the new one.
  2. After replacing the image drum unit, be sure to reset its counter in the User Maintenance mode.
  3. After replacing the LED head assembly, be sure to adjust its drive time and correct its color deviation.





**(6) Poor fusing (Images are blurred or peeled off when touched)**

- Is the paper under specification being used?

  - No Use the paper under the specification.
- Yes Is contacts of the fusing unit assembly connected correctly?

  - No Connect the contacts correctly.
- Yes Are there any rollers of the fusing unit (heat roller, oil roller, or cleaning oil roller) contaminated?

  - Yes Replace the fusing unit assembly or oil roller assembly.
- No Is the setting of "MEDIA TYPE" (in menu 1) correctly?  
 LIGHT:60g/m<sup>2</sup> LIGHT MEDIUM:67.5g/m<sup>2</sup> MEDIUM:75g/m<sup>2</sup> MEDIUM HEAVY:90g/m<sup>2</sup>  
 HEAVY:105g/m<sup>2</sup> ULTRA HEAVY:120g/m<sup>2</sup> TRANSPARENCY:OHP

  - No Set the "MEDIA TYPE" correctly.
- Yes Is AC voltage between pin 1 and 3 of the CN1 connector of the low-voltage power supply being supplied?

  - No Replace the low-voltage power supply.
- Yes Is resistance range of the heat roller thermistor under the regulation? (See Figure 6.1.) (It's about between 90 ohms and 700 ohms at room temperature of 0°C to 43°C)

  - No Replace the fusing unit assembly.
- Yes Is resistance range of the backup roller thermistor under the regulation? (See Figure 6.1.) (It's about between 90 ohms and 700 ohms at room temperature of 0°C to 43°C)

  - No Replace the fusing unit assembly.
- Yes Is the signal THERM1 on pin 6 of the THERM connector of the engine board (PX4 PCB) in the following range?

LIGHT and LIGHT MEDIUM:2.8V~3.5V	MEDIUM:3.1V~3.8V
MEDIUM HEAVY:3.1V~3.9V	HEAVY:3.4V~4V
ULTRA HEAVY:3.4V~4.1V	TRANSPARENCY default value:3.4V~4V

  - No Replace the fusing unit assembly.
- Yes Replace the fusing unit assembly.

- Notes:
1. When replacing the engine board (PX4 PCB), demount the EEPROM chip from the old engine board and remount it on the new one.
  2. After replacing the image drum unit, the fusing unit, and the belt cassette assembly, be sure to reset their counters in the User Maintenance mode.
  3. After replacing the LED head assembly, be sure to adjust its drive time and correct its color deviation.





**(7) Evenly spaced, repeating marks (Cyclical printout defects)**

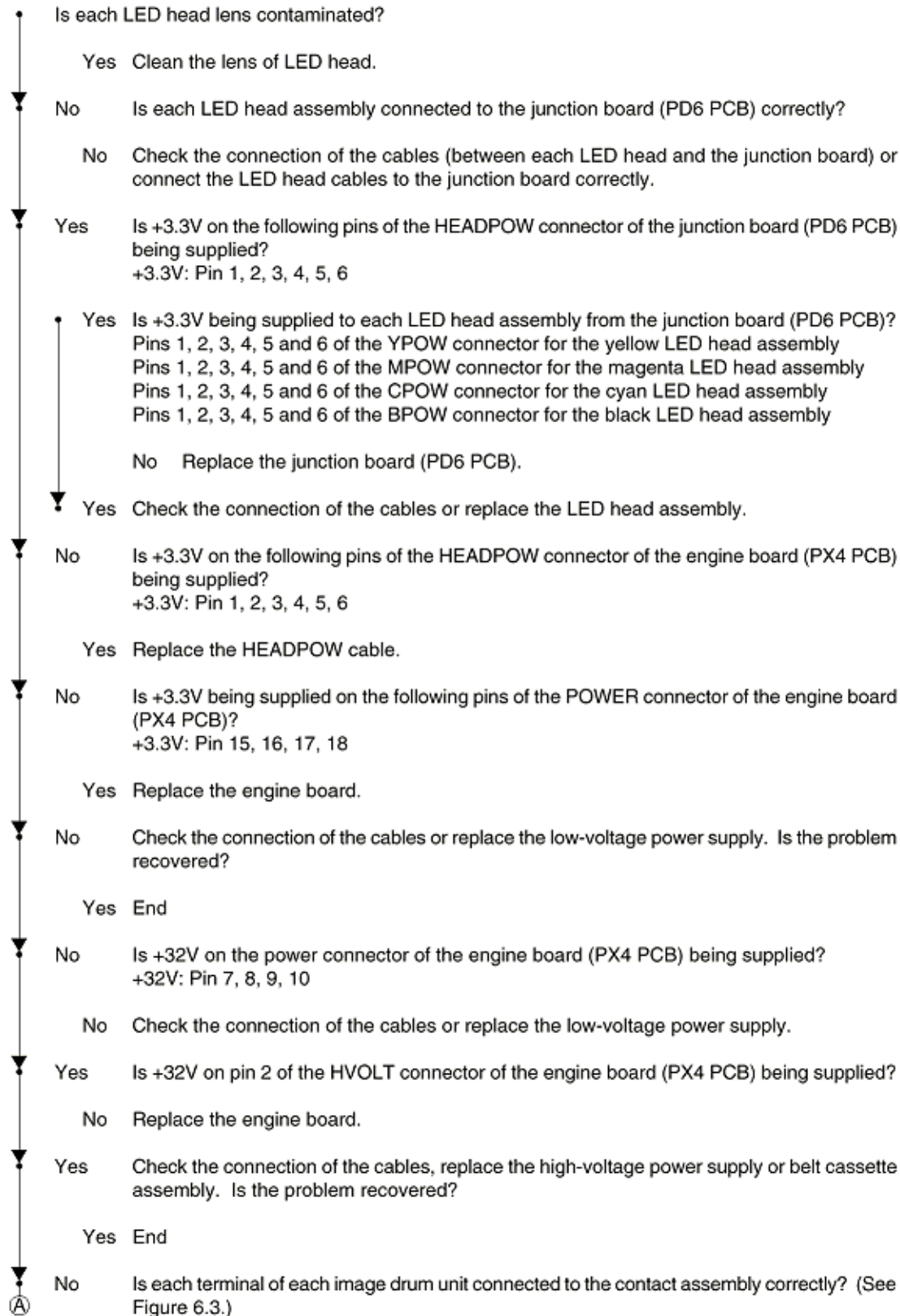
	<b>Possibly defective part</b>	<b>Repairing</b>
94.2 mm	Image Drum	Replace the image drum unit.
44.0 mm	Developing Roller	Replace the image drum unit.
28.3 mm	Toner Supply Roller	Replace the image drum unit.
28.3 mm	Charging Roller	Replace the image drum unit.
114 mm	Heat Roller	Replace the fusing unit assembly.
114 mm	Pressure Roller	Replace the fusing unit assembly.
47.1 mm	Transfer Roller	Replace the Transfer Belt assembly.

**Note:** After replacing the image drum unit the fusing unit and the Transfer Belt cassette assembly, be sure to reset their counters in the User Maintenance mode.



---

**(8) Missing characters or colors**



Ⓐ



No Make the terminals be in contact with the contact assembly correctly.

Yes Replace the the image drum unit.

- Notes:
1. When replacing the engine board (PX4 PCB), demount the EEPROM chip from the old engine board and remount it on the new one.
  2. After replacing the image drum unit and the belt cassette assembly, be sure to reset their counters in the User Maintenance mode.
  3. After replacing the LED head assembly, be sure to adjust its drive time and correct its color deviation.



**(9) Poor synthesization Color**

- Correct color deviations of each LED head by "COLOR REG ADJUST EXECUTE." Is the problem recovered?
  - Yes End
- ▼ No Are there any gear broken of the unit (Image drum unit gear assembly, front feeder assembly, belt unit assembly or belt motor assembly, etc.)?
  - Yes Replace the broken gear assembly.
- ▼ No Is each LED head unit connected to the junction board (PD6 PCB) correctly?
  - No Connect the boards correctly.
- ▼ Yes Check the connection of the cables or replace the LED head assembly. Is the problem recovered?
  - Yes End
- ▼ No Check the connection of the cables or replace the junction board (PD6 PCB). Is the problem recovered?
  - Yes End
- ▼ No Is engine board (PX4 PCB) connected to the junction board (PD6 PCB) correctly?
  - No Connect the boards correctly.
- ▼ Yes Check the connection of the cables or replace EEPROM of the engine board. Is the problem recovered?
  - Yes End
- ▼ No Replace the engine board. Recovered?
  - Yes End
- ▼ No Is each terminal of each image drum unit connected to the contact assembly correctly? (See Figure 6.3.)
  - No Make the terminals be in contact with the contact assembly correctly.
- ▼ Yes Replace the the image drum unit.

- Notes:
1. When replacing the engine board (PX4 PCB), demount the EEPROM chip from the old engine board and remount it on the new one.
  2. After replacing the image drum unit, be sure to reset its counter in the User Maintenance mode.
  3. After replacing the LED head assembly, be sure to adjust its drive time and correct its color deviation.

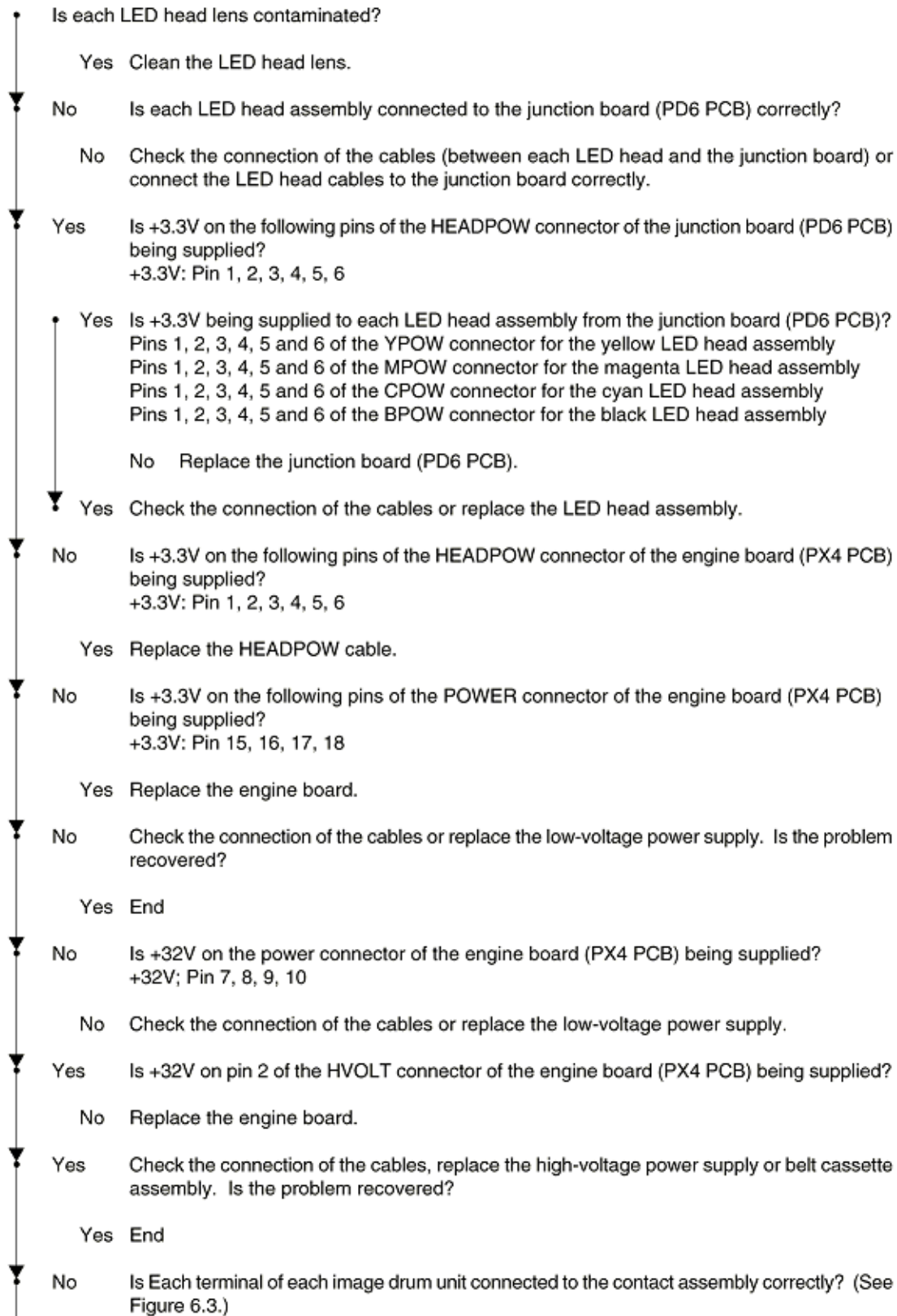






---

(10) Printout colors diferent from original colors

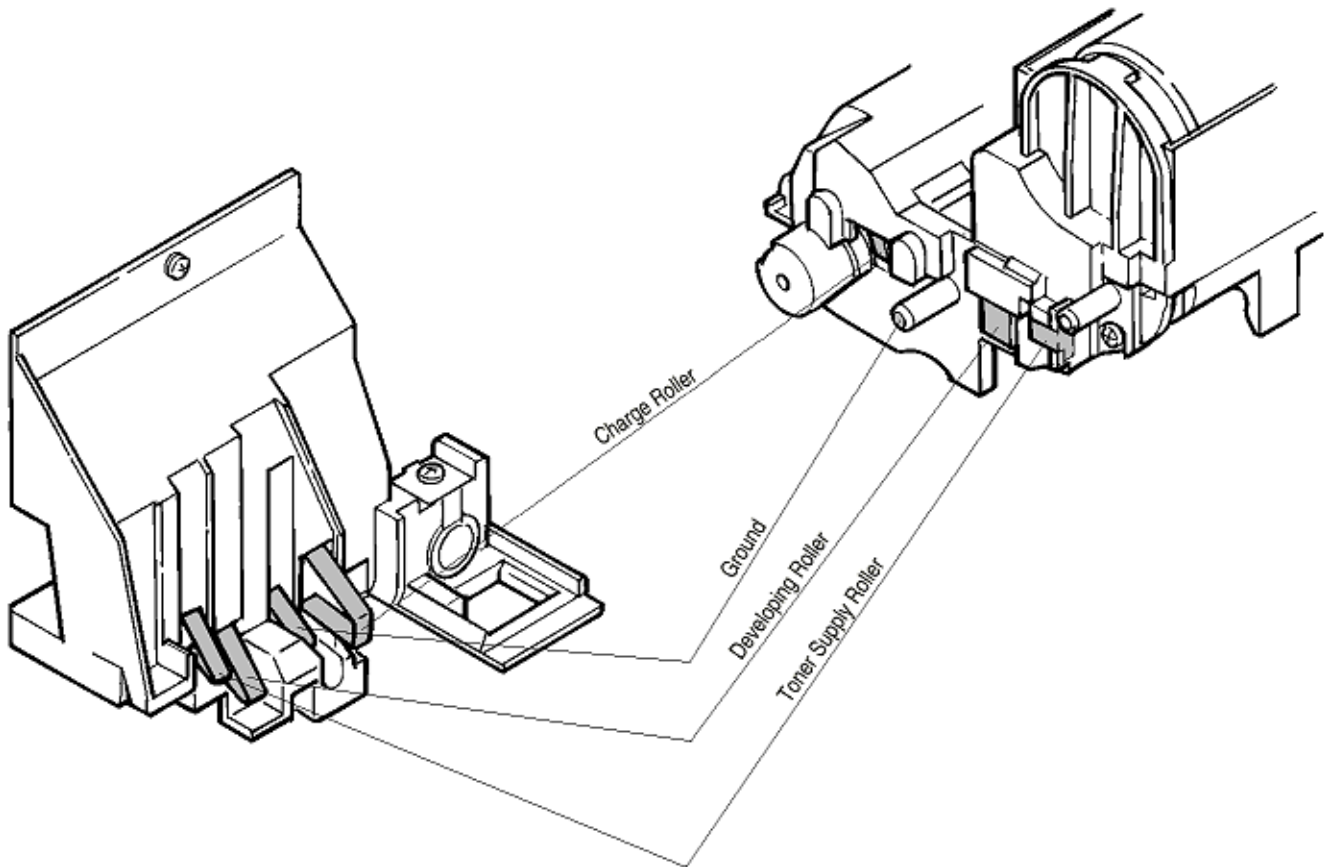




No Make the terminals be in contact with the contact assembly correctly.

Yes Replace the the image drum unit.

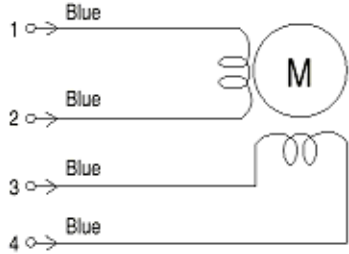
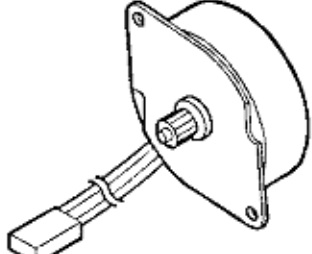
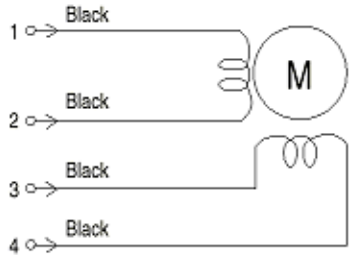
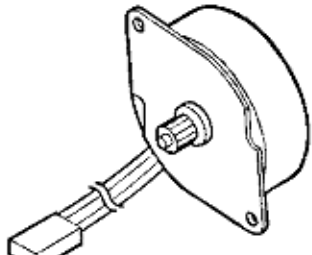
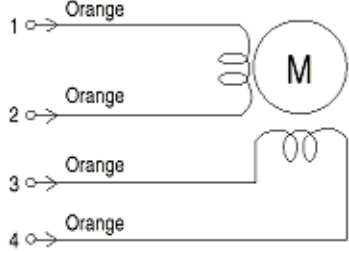
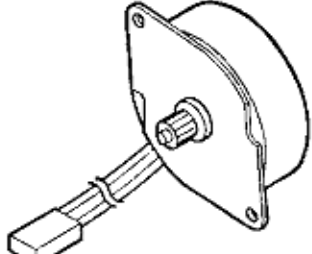
- Notes:
1. When replacing the engine board (PX4 PCB), demount the EEPROM chip from the old engine board and remount it on the new one.
  2. After replacing the image drum unit and the belt cassette assembly, be sure to reset their counters in the User Maintenance mode.
  3. After replacing the LED head assembly, be sure to adjust its drive time and correct its color deviation.





7.1 Resistance Check

Unit	Circuit Diagram	Illustration	Resistance
Belt motor	<p>1 → White 2 → White 3 → White 4 → White</p>		<p>Between pins 1 and 2: 7.1Ω Between pins 3 and 4: 7.1Ω</p>
YIDU motor	<p>1 → Yellow 2 → Yellow 3 → Yellow 4 → Yellow</p>		<p>Between pins 1 and 2: 7.1Ω Between pins 3 and 4: 7.1Ω</p>
MIDU motor	<p>1 → Red 2 → Red 3 → Red 4 → Red</p>		<p>Between pins 1 and 2: 7.1Ω Between pins 3 and 4: 7.1Ω</p>

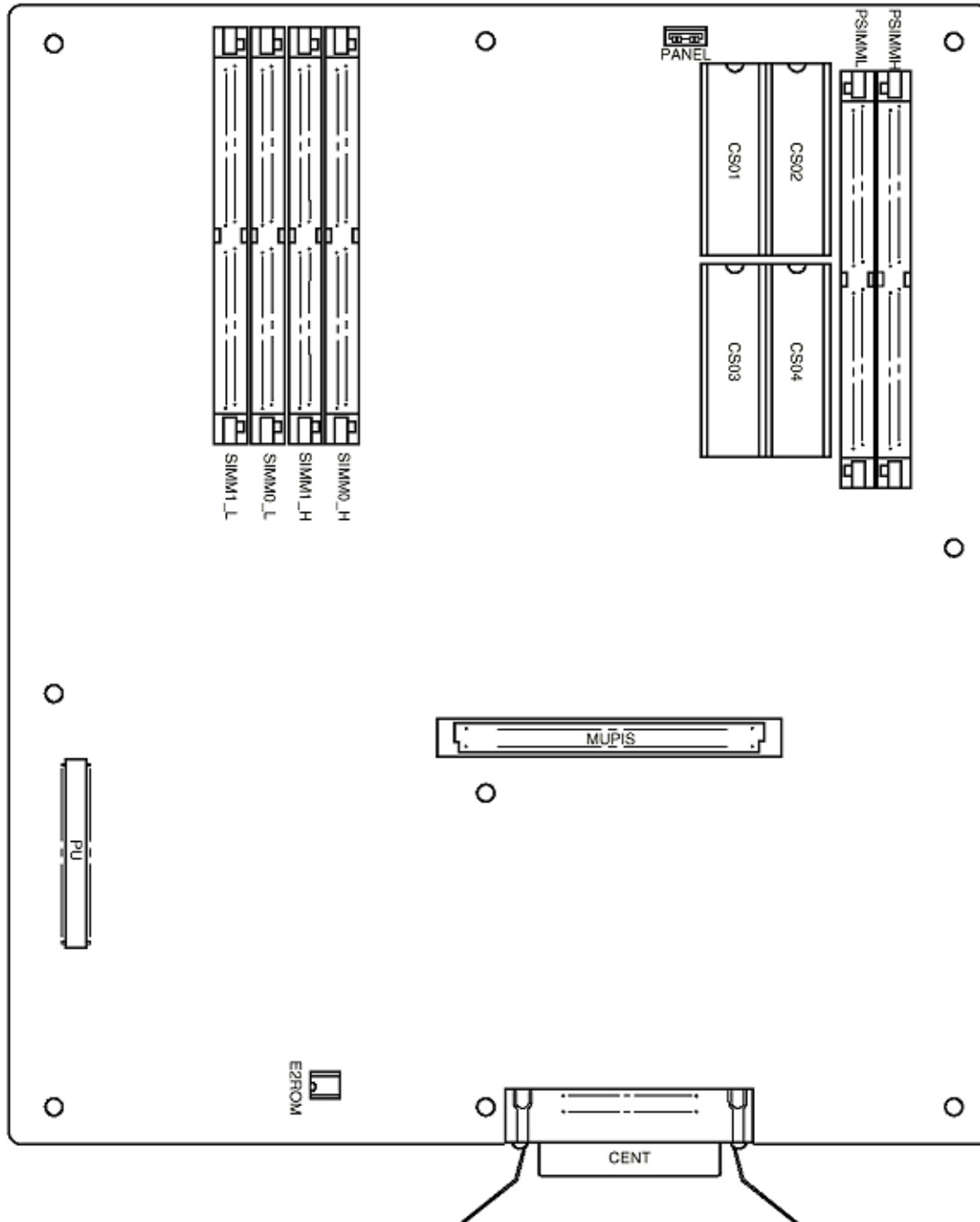
Unit	Circuit Diagram	Illustration	Resistance
CIDU motor	 <p>1 → Blue 2 → Blue 3 → Blue 4 → Blue</p>		<p>Between pins 1 and 2: 7.1Ω Between pins 3 and 4: 7.1Ω</p>
BIDU motor	 <p>1 → Black 2 → Black 3 → Black 4 → Black</p>		<p>Between pins 1 and 2: 7.1Ω Between pins 3 and 4: 7.1Ω</p>
Resist motor	 <p>1 → Orange 2 → Orange 3 → Orange 4 → Orange</p>		<p>Between pins 1 and 2: 7.1Ω Between pins 3 and 4: 7.1Ω</p>

Unit	Circuit Diagram	Illustration	Resistance
Heater motor			Between pins 1 and 2: 7.1Ω Between pins 3 and 4: 7.1Ω
FF motor			Between pins 1 and 2: 7.1Ω Between pins 3 and 4: 7.1Ω

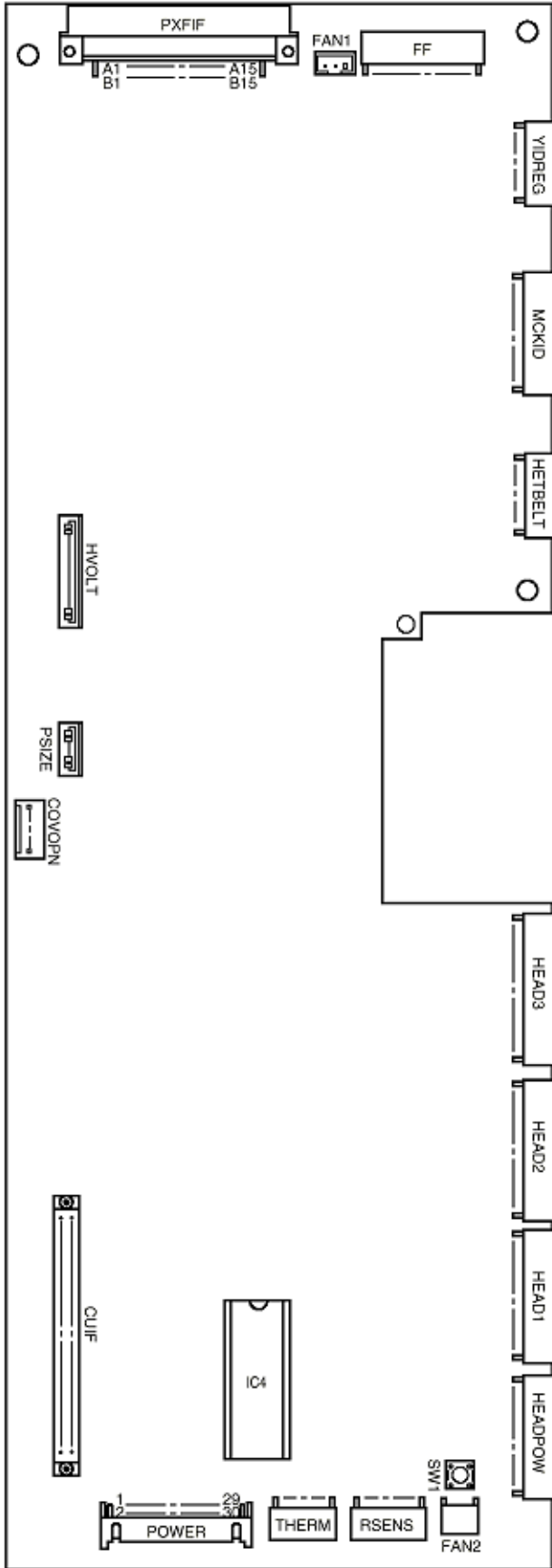
Unit	Circuit Diagram	Illustration	Resistance
Fan 1 (To: Low Power supply)			
Fan 2 (To: PX4-PCB)			
Fusing Unit			Between pins c and d: 205kΩ (at 25°C) Between pins e and f: 205kΩ (at 25°C) Between pins a and b: 2.3kΩ (120V, at 25°C) 8.5Ω (240V, at 25°C)



7.2 Program/Font ROM Location  
(1) PCE-PCB (Main Board)

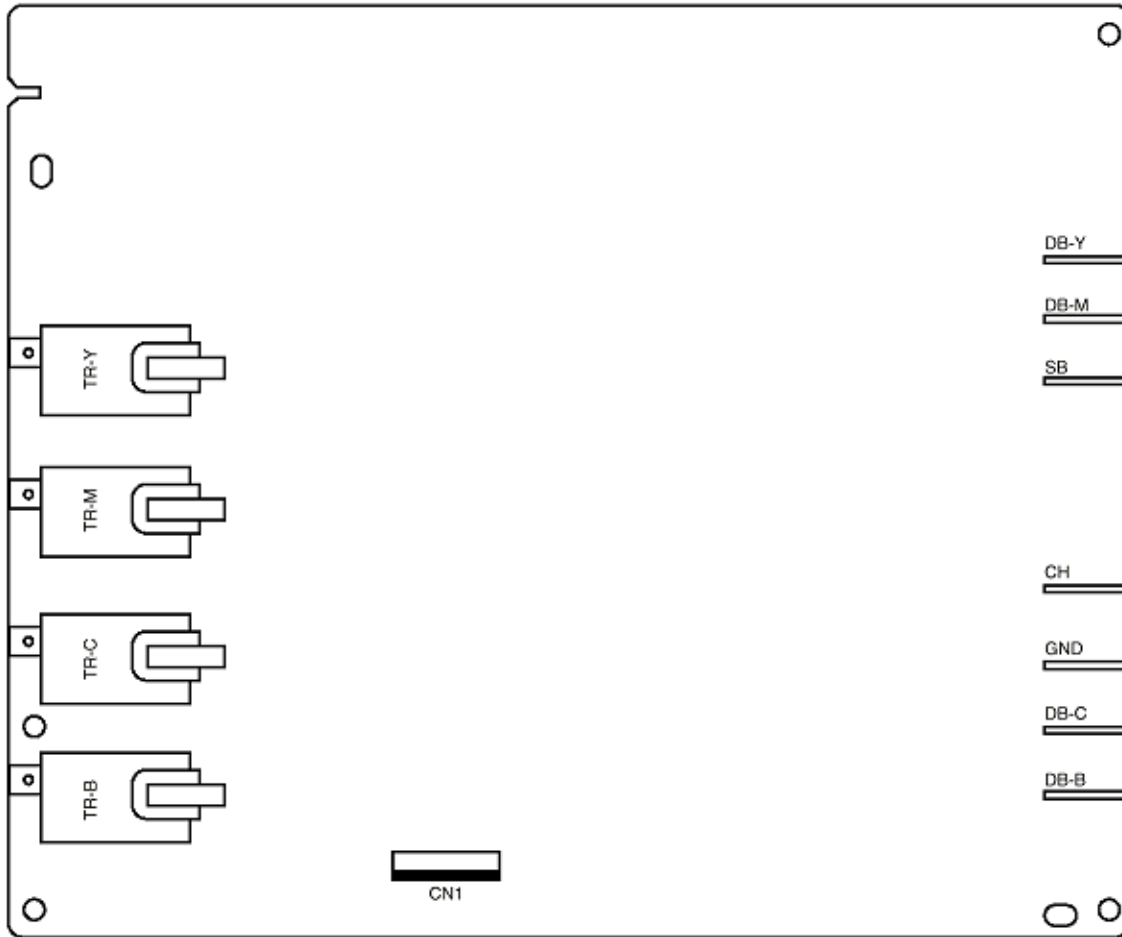


(2) PX4-PCB (Engine Board)

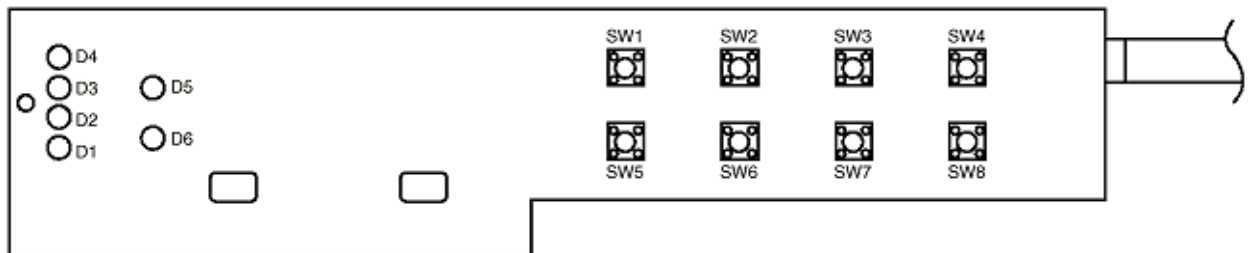




**(3) Power-Supply PCB**



**(4) PCO PCB**



**(5) PXF PCB**

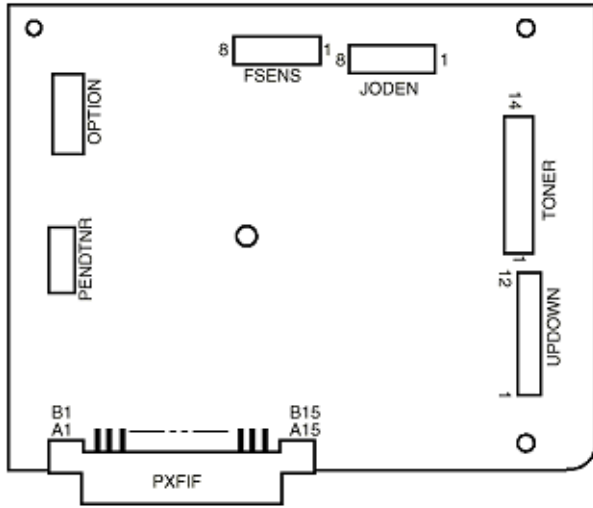
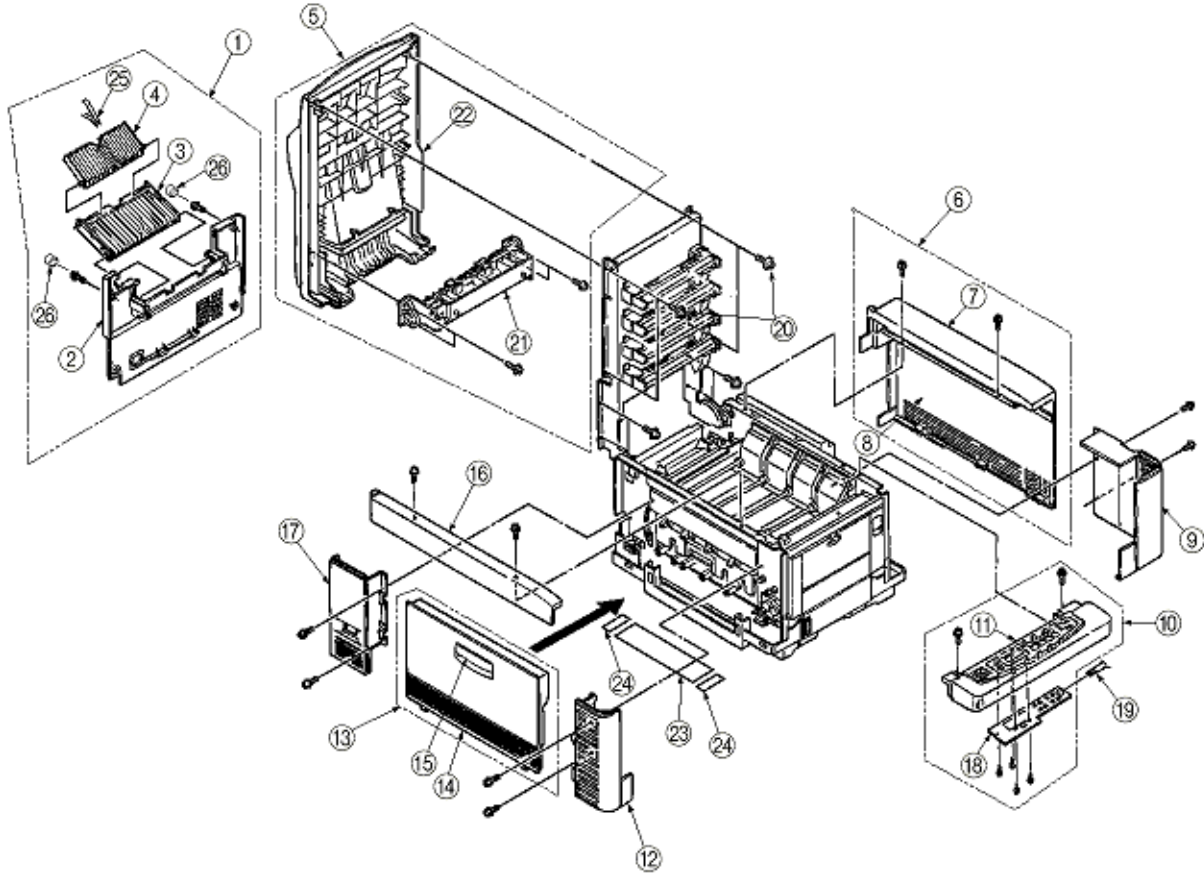
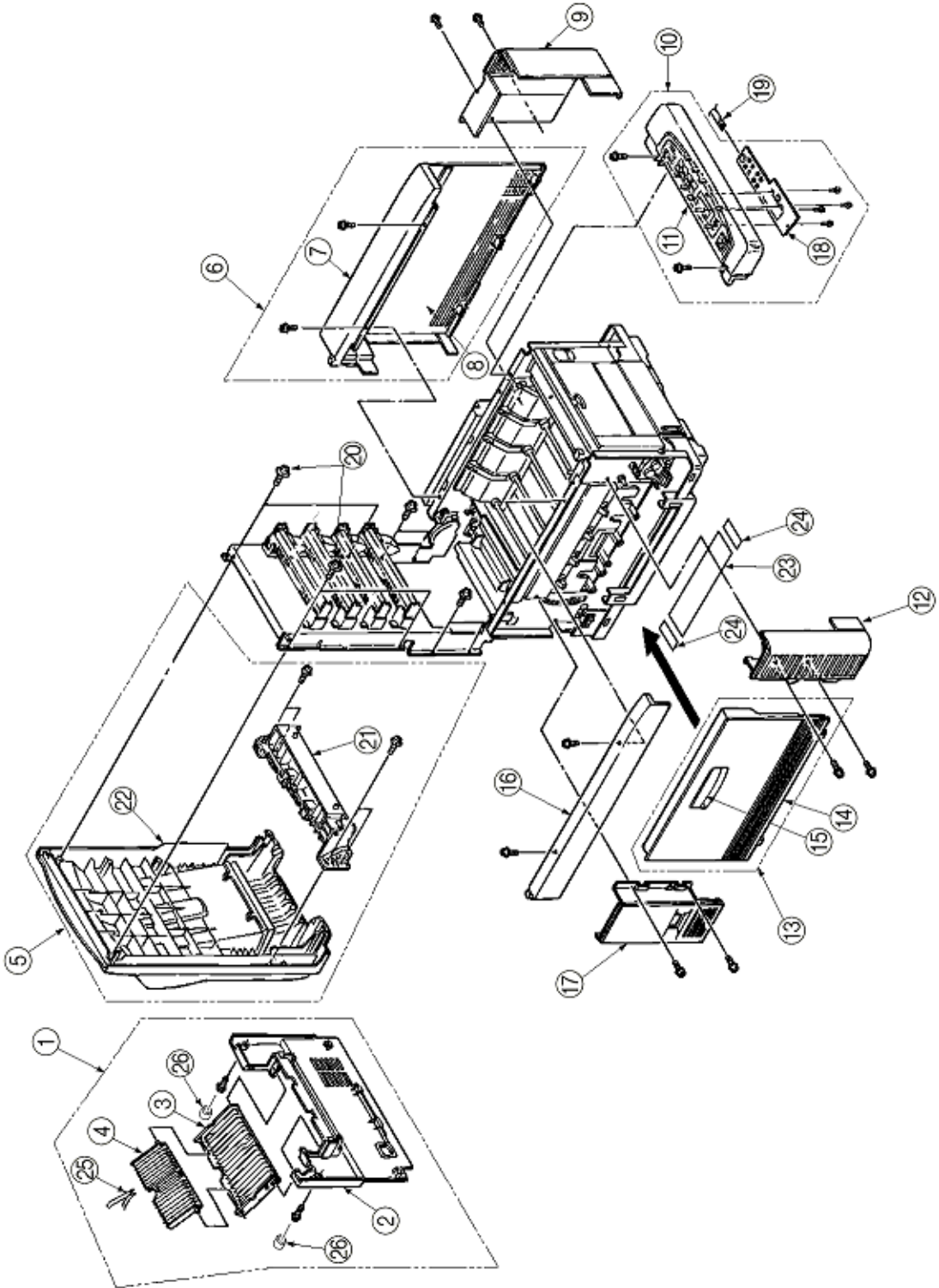




Figure 8-1: Covers (Top & Sides)



< same diagram -- side view >



No.	Okidata Part #	Name	Qty	Remarks
1	40315201	Cover Assy Rear	1	
2	40098401	Cover Rear	1	
3	40187501	Stacker Faceup	1	

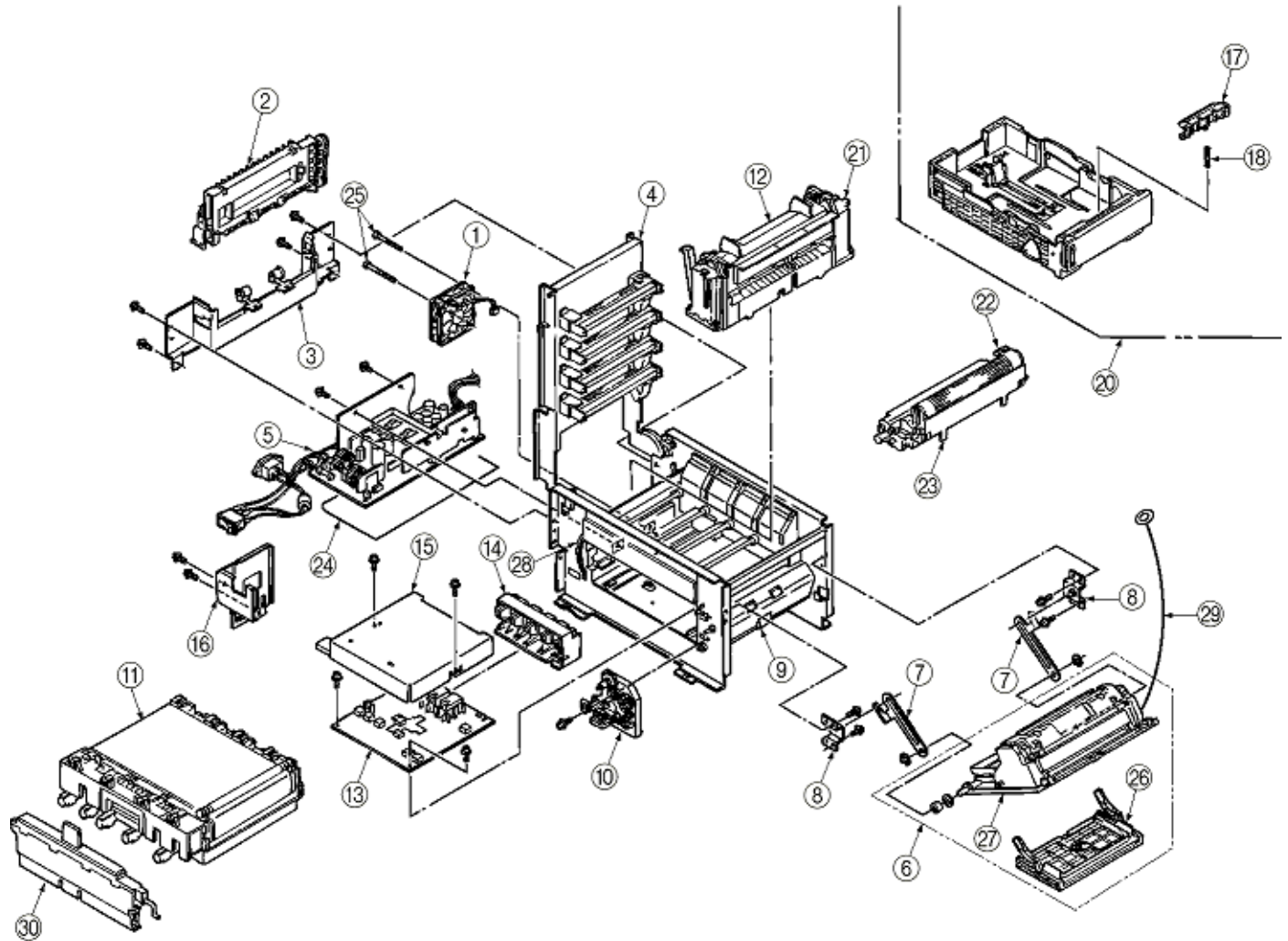
4	40187601	Support Stacker	1	
5	40314801	Cover Assy Stacker	1	
6	40315001	Cover Assy Side (R)	1	
7	-	Cover Side (R)	1	
8	-	Frame Side (R)	1	
9	40098301	Cover Front (R)	1	
10	40314901	Cover Assy OP Panel	1	(120V)
11	40492604	Cover Sub Assy OP Panel	1	
12	40098201	Cover Front (L)	1	
13	40315101	Cover Assy Side (L)	1	
14	-	Cover Side (L)	1	
15	-	Cover Knob	1	
16	40195601	Frame Side (L)	1	
17	40195701	Cover Rear (L)	1	
18	40387201	Board - PCO	1	
19	40919301	Connection Code Sumi Cord Assy	1	
20	50318701	Screw	4	
21	40303601	Guide Eject FD Assy	1	
22	40449901	Cover Sub Assy Stacker	1	
23	40728601	Film Waste Toner	1	
24	40728701	Foam - Seal (Cover)	2	
25	40664701	Spring - Support (FU)	1	

---

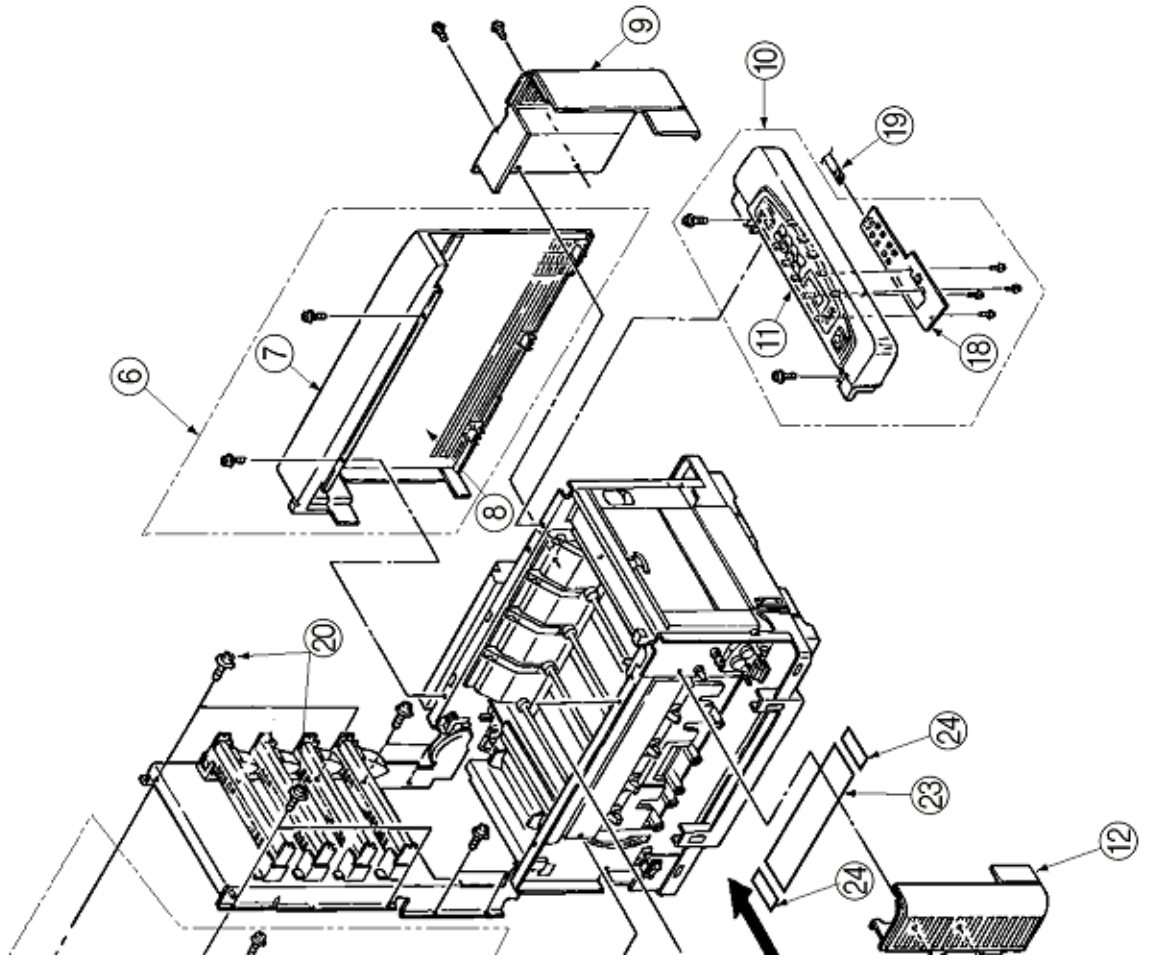
Copyright 1999, Okidata, Division of OKI America, Inc. All rights reserved.



Figure 8-2: Printer Unit



< same diagram -- side view >

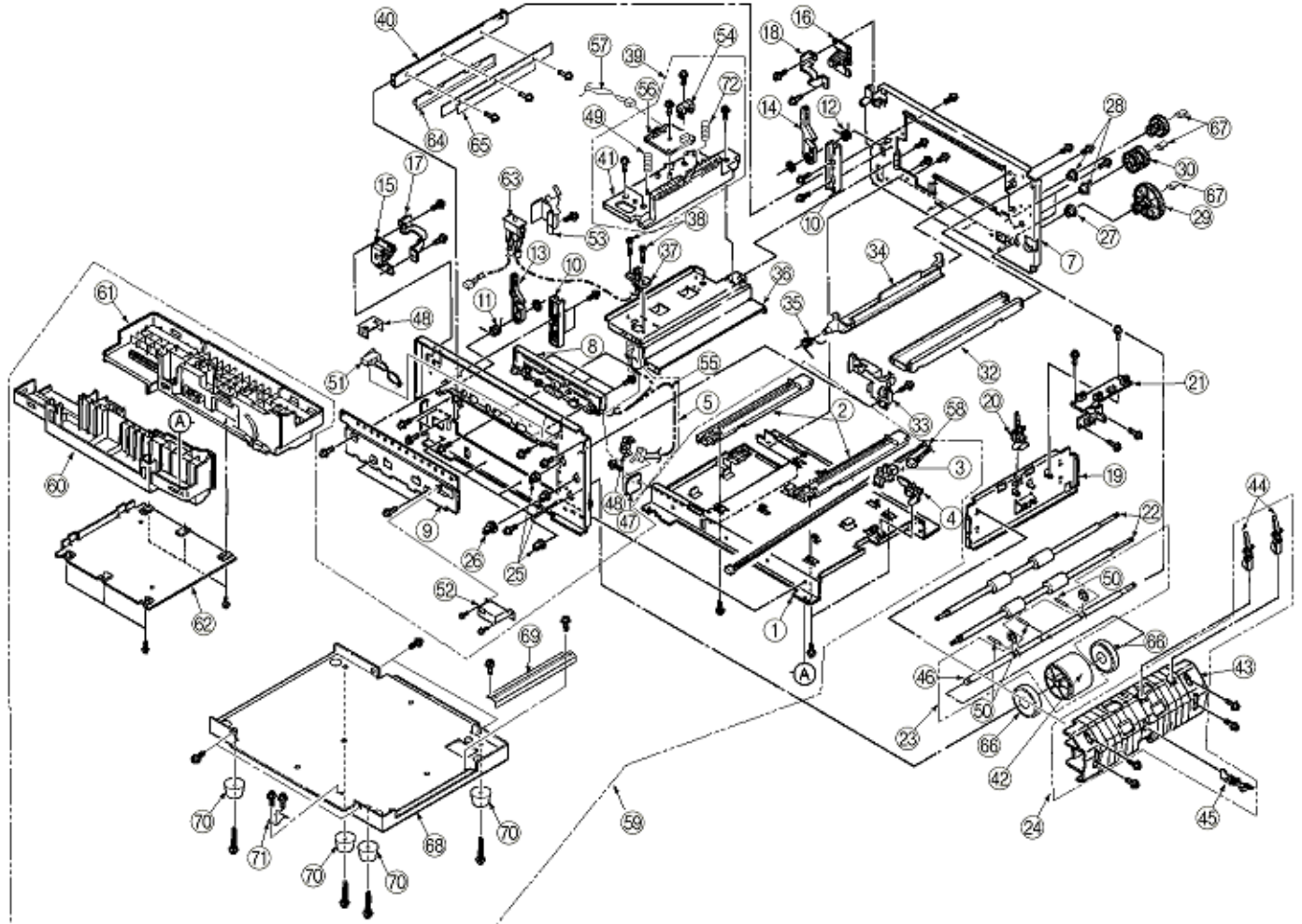


No.	Okidata Part #	Name	Qty	Remarks
1	40255201	Motor Fan (80-25)	1	
2	40303501	Frame Eject Assy	1	
3	40303401	Guide Paper Eject Assy	1	
4	40410701	Frame Upper Assy	1	
5	40018901	Power Unit ACDC Switching	1	120V
	40019001	Power Unit ACDC Switching	1	230V
6	40311201	FDR Unit Front	1	
7	40193501	Plate FF Link	1	
8	40193601	Bracket FF Link	1	
9	40303301	Guide Paper Input Assy	1	
10	40309801	Holder Gear Toner Assy	1	
11	40490801	Belt Unit	1	
12	40645301	Oil Roller Unit	1	
13	40065601	High Voltage Power Supply	1	
14	40325001	Bracket HV (BT) Assy	1	
15	40168001	Plate HV	1	
16	40193201	Holder Innret	1	
17	40607101	Separator Frame Assy	1	
18	41179801	Separation Spring	1	
19	-			
20	40744401	Paper Cassette Assy	1	
21	40490901	Fuser Uit	1	120V
	40490904	Fuser Unit	1	230V
22	41012317	Toner Cartridge BK	1	
	41012318	Toner Cartridge Y	1	
	41012319	Toner Cartridge M	1	
	41012320	Toner Cartridge C	1	
23	41070217	Image Drum Unit BK	1	
	41070218	Image Drum Unit Y	1	
	41070219	Image Drum Unit M	1	
	41070220	Image Drum Unit C	1	
24	40191201	Sheet Insulation	1	
25				
26	40838801	Manual Hopper Assy	1	
27	40449001	FDR Unit Main Assy	1	
28	40294201	CONN Cord Wire	1	
29	40641801	CONN Cord Wire	1	
30	40645401	Waste Toner Box	1	

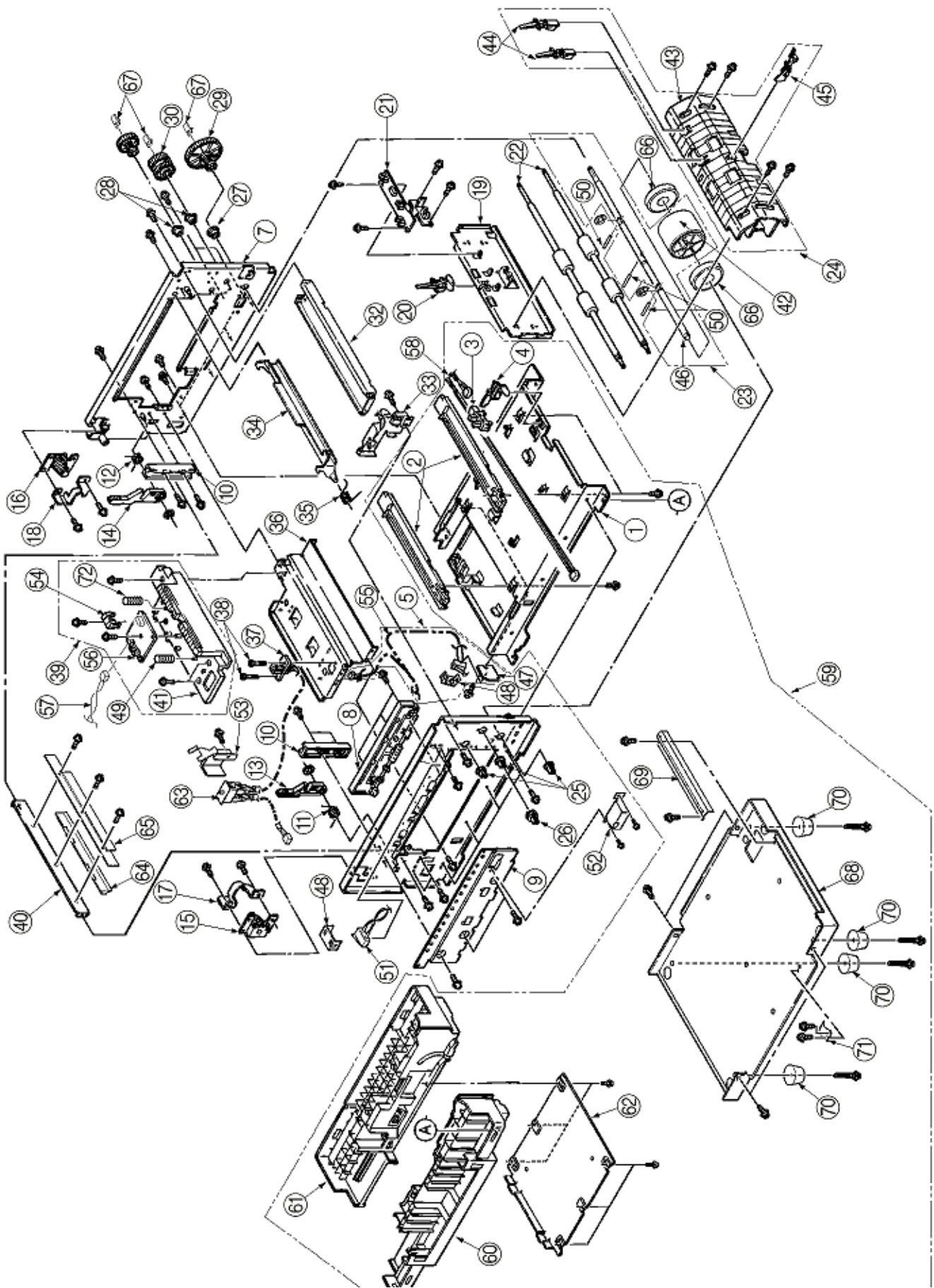




Figure 8-3: Main Chassis Unit (1)



< same diagram -- side view >



No.	Okidata Part #	Name	Qty	Remarks
1	40175701	Plate Base	1	
2	40096401	Guide Belt (F)	2	
3	40135301	Photo Interrupter	1	
4	50808201	Lever Paper End	1	
5	40450401	Sensor Assy Box Toner	1	120V
	40171401	Frame Side (L)	1	230V
6	40171301	Frame Side (R)	1	
7	40308801	Contact SB Assy	1	
8	40290201	Plate Blind	1	
9	40163401	Guide Side Heat Unit	1	
10	40163701	Spring Lock (L)	2	
11	40163701	Spring Lock Heat	1	
12	40835001	Spring Lock (L)	1	
13	40163501	Lever Lock Heat Unit (L)	1	
14	40163601	Lever Lock Heat Unit (R)	1	
15	40383701	Limitier - 2 Way (L)	1	
16	40383801	Limitier - 2 Way R)	1	
17	40335001	Plate Guard (L)	1	
18	40335101	Plate Guard (R)	1	
19	40171201	Stay Lower (Front)	1	
20	40144501	Lever Regist Sensor	1	
21	40437601	Board - PXM	1	
22	40130801	Roller Registration	2	
23	40310601	Roller Assy Hopping	1	
24	40303301	Guide Paper Input Assy	1	
25	40261301	Bearing Hopping	3	
26	40130301	Gear Z20	1	
27	51608201	Bearing F	1	
28	51607301	Bush	2	
29	40250901	Gear Oneway (96)	1	
30	40164301	Gear Oneway (Z48)	2	
31			1	
32	40171101	Stay Upper (Front)	1	
33	40388501	Bracket SW	1	
34	40195101	Plate Latchlever (FD)	1	
35	40195001	Spring Latchlever (FD)	1	
36	40175201	Stay Heat	1	
37	40563101	Connection cord wire	1	
38	50318601	Screw	2	
39	40162101	Guide Assy Heat Unit	1	
40	40175101	Stay EP	1	
41	40449401	Guide Assy Heat	1	
42	40449701	Hopping Roller Boss Assy	1	
43	40097301	Guide Paper Input A	1	
44	40144301	Lever Input Sensor	2	
45	40144401	Lever 2nd Feed Sensor	1	
46	40189601	Shaft Hopping Roller (1st)	1	
47	40450201	Bracket Switch	1	
48	40408601	Holder Switch	4	
49	40264401	Spring Eject Heat	1	
50	50608118	Knock Pin	1	
51	40447201	CONN Cord Wire	1	
52	40388401	Bracket Switch (Side)	1	
53	40446501	InterLock Sw Cable Assy	1	
54	40162201	Cover Sensor	1	
55	40172401	AMP6P-AMP4P	1	
56	40437501	Board - PXL	1	

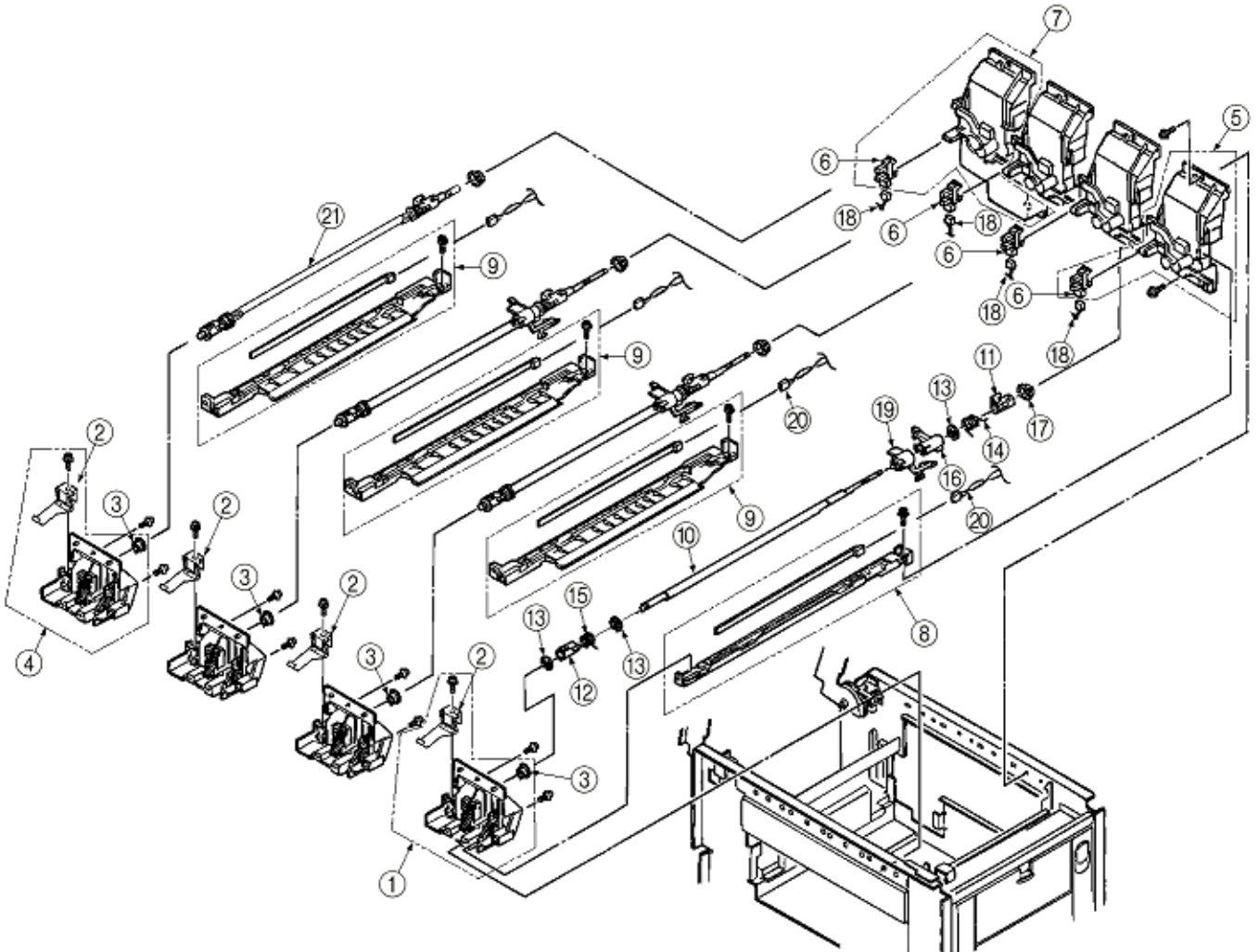
57	40171801	Cordwire AMP7P AMP7P	1	
58	40447301	Cordwire JST6P AMP3PX2	1	
59	40303201	Plate Base Assy	1	
60	40303101	Guide Cassette (L) Assy	1	
61	40302901	Guide Cassette (R) Assy	1	
62	40164801	Plate Bottom	1	
63	40448501	Connection cord wire	1	
64	40551301	Plate Shield Heat	1	
65	40714401	Heat - Sink (801)	1	
66	40743701	Roller Assy - Hopping (Sub)	1	
67	40686701	Spacer - Regist Gear	3	
68	40661001	Cover - Bottom (Weld)	1	
69	40661501	Plate - Guide	1	
70	40671001	Rubber - Foot	1	
71	51025202	Plate: Ground Contact	1	
72	40834901	Spring - Eject - Heat	1	

---

Copyright 1999, Okidata, Division of OKI America, Inc. All rights reserved.

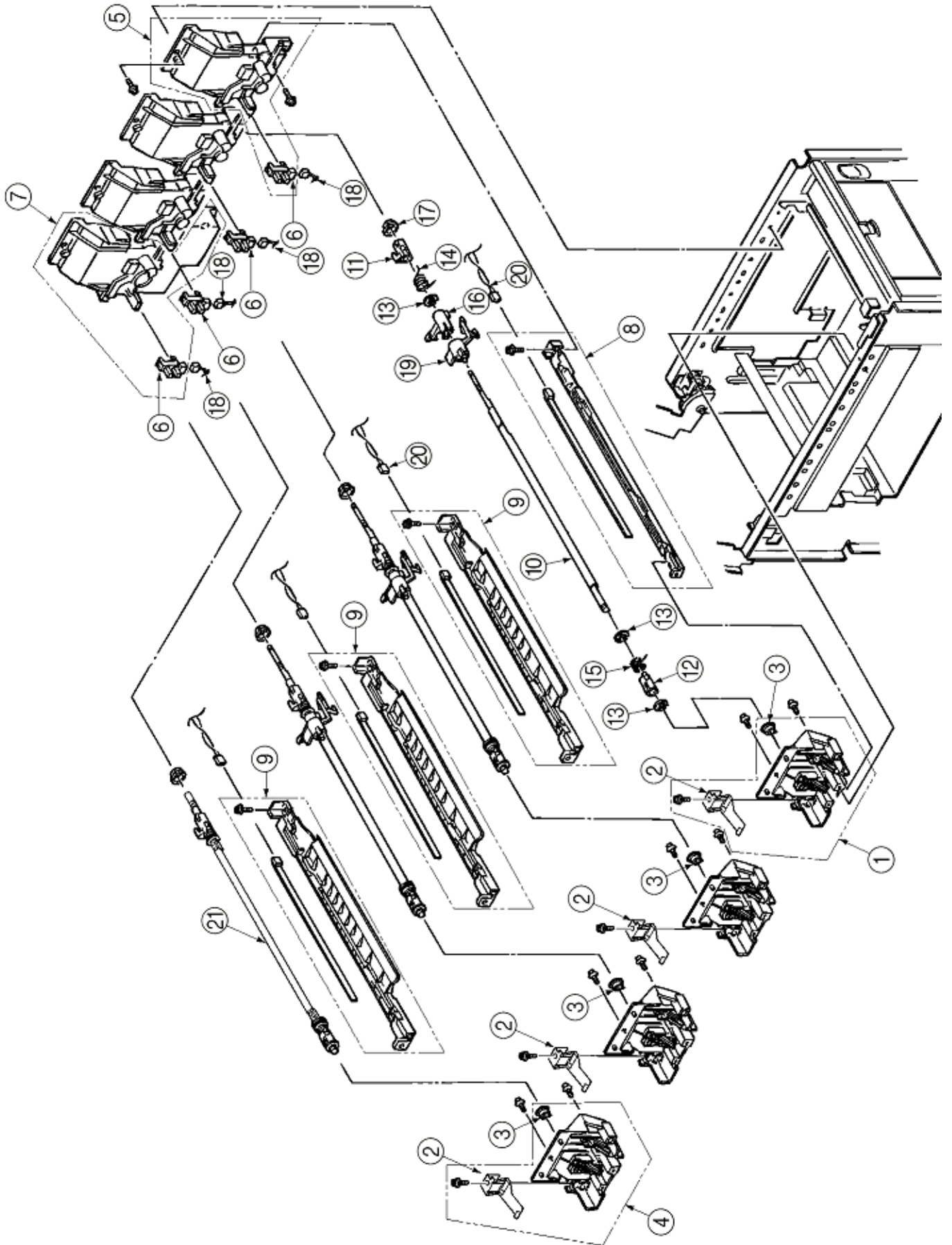


Figure 8-4: Main Chassis Unit (2)



< same diagram -- side view >





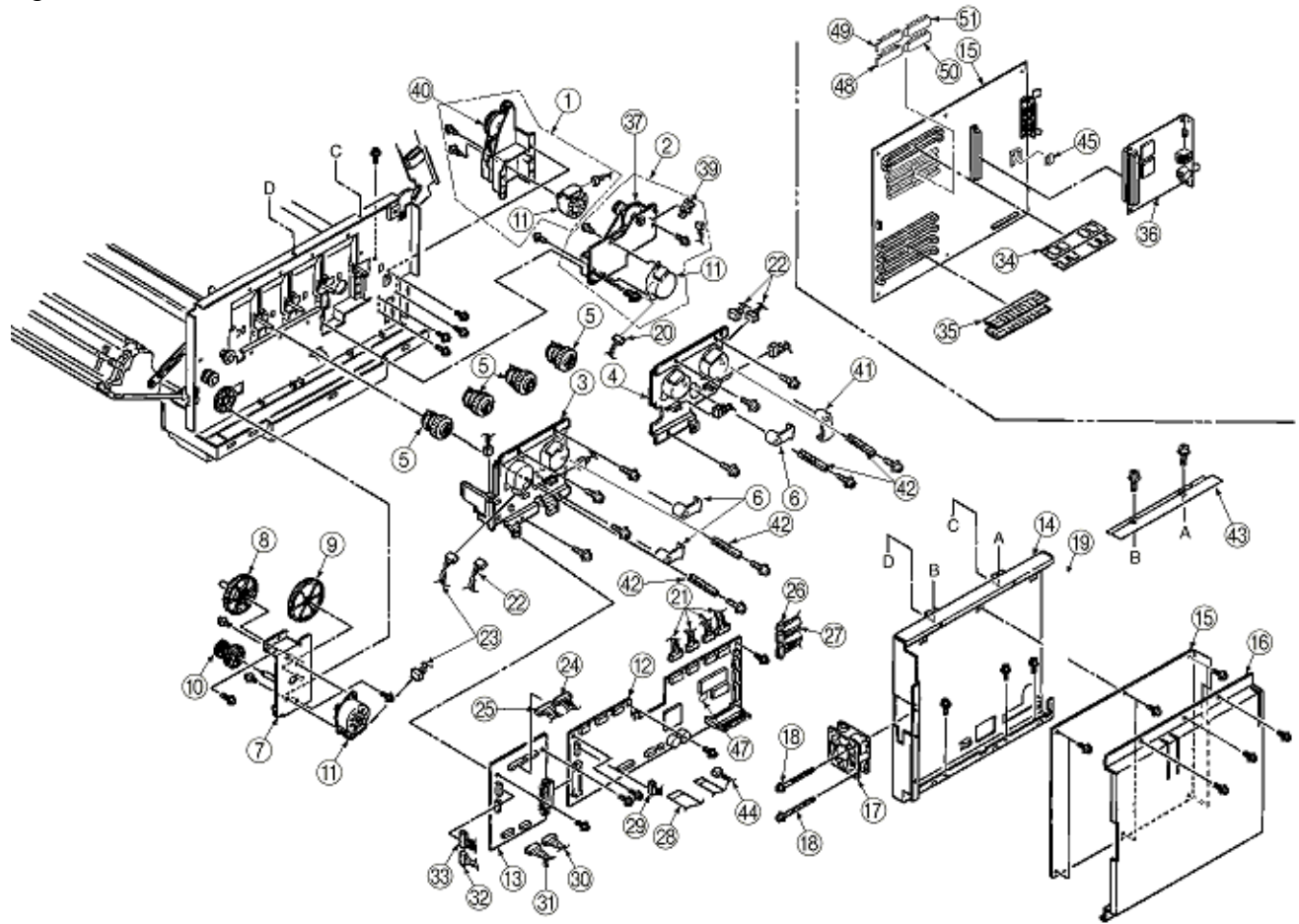
No.	Okidata Part #	Name	Qty	Remarks
1	40324501	Contact (BL L ) Assy	1	Includes Item 2, 3
2	40278101	Plate Earth (LK)	1	
3	51608201	Bearing	1	
4	43024401	Contact (CL L) Assy	1	Includes Item 2, 3
5	40324601	Contact BKT (BL R) Assy	1	Includes Item 6
6	40135301	Photo Interrupter	1	
7	40309001	Contact BKT (CL R) Assy	1	Includes Item 6
8	40308501	Eraser BKT Assy	1	
9	40324301	Eraser BKT (KCM) Assy	1	
10	40167901	Shaft Link	1	
11	40132301	Lever Link (R)	1	
12	40132401	Lever Link (L)	1	
13	50705301	E Ring	1	
14	40168401	Spring Support (R)	1	
15	40188501	Spring Support (L)	1	
16	* see #19	Bracket Sensor Toner (KCM)	1	Included with #19
17	51608901	Bearing	1	
18	40173301	AMP14P-AMP3X4	1	
19	41223601	Sensor Assy T (KCM)	1	
20	40172701	Cordwire AMP8P AMP2PX4	1	
21	40664301	Shaft (k) Assy	1	

---

Copyright 1999, Okidata, Division of OKI America, Inc. All rights reserved.

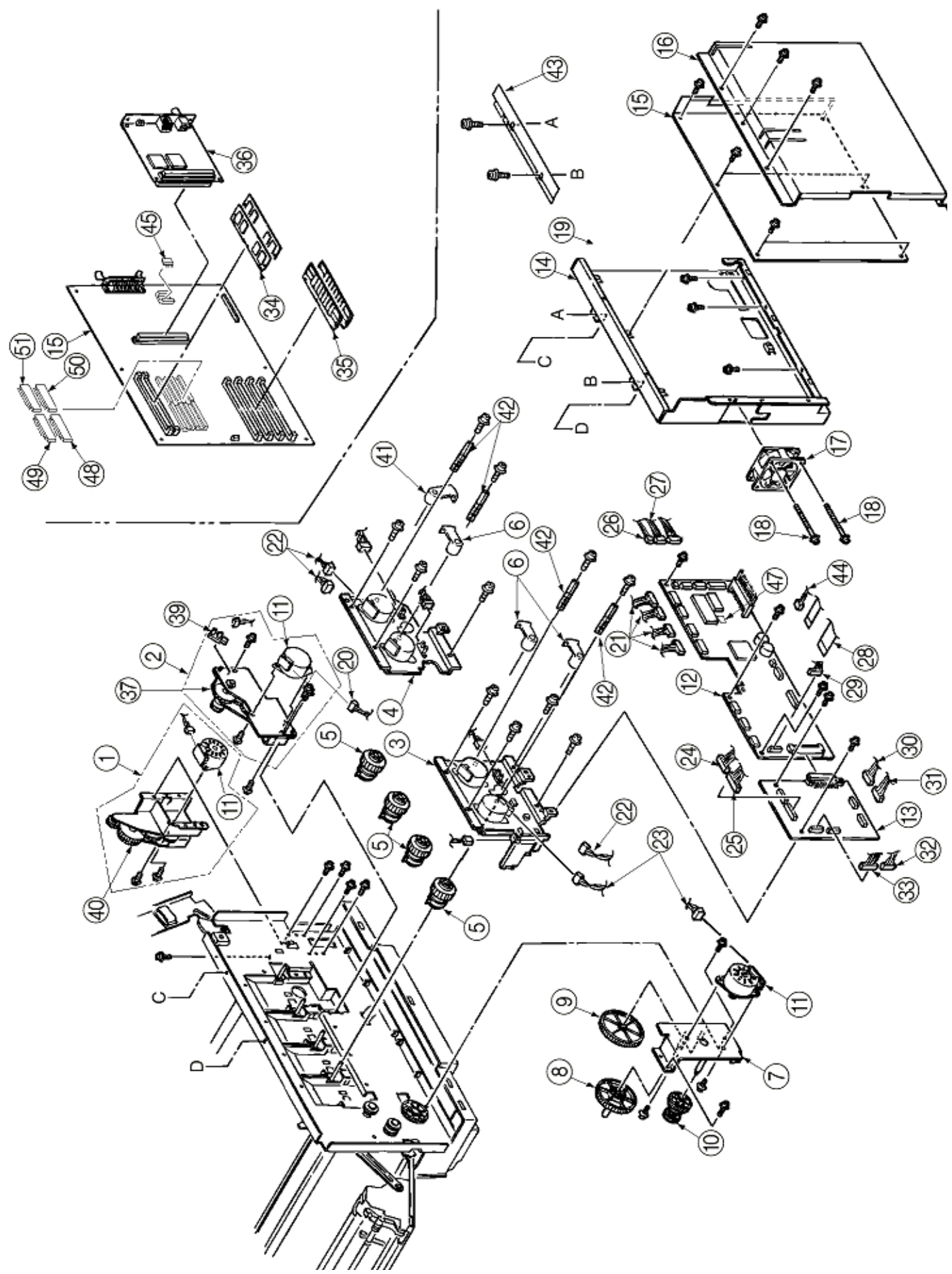


Figure 8-5: Main Chassis Motor/PCB



< same diagram -- side view >

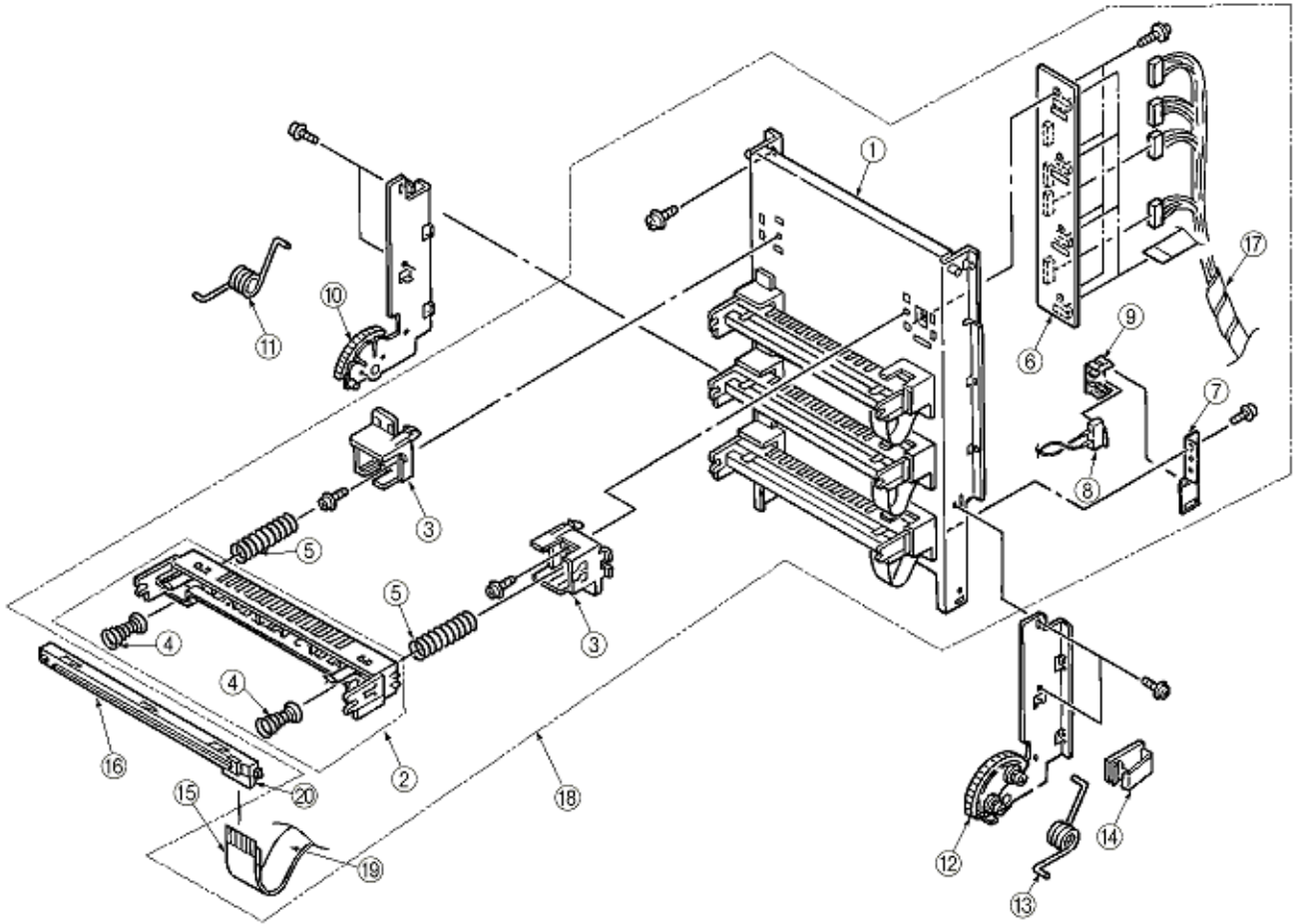




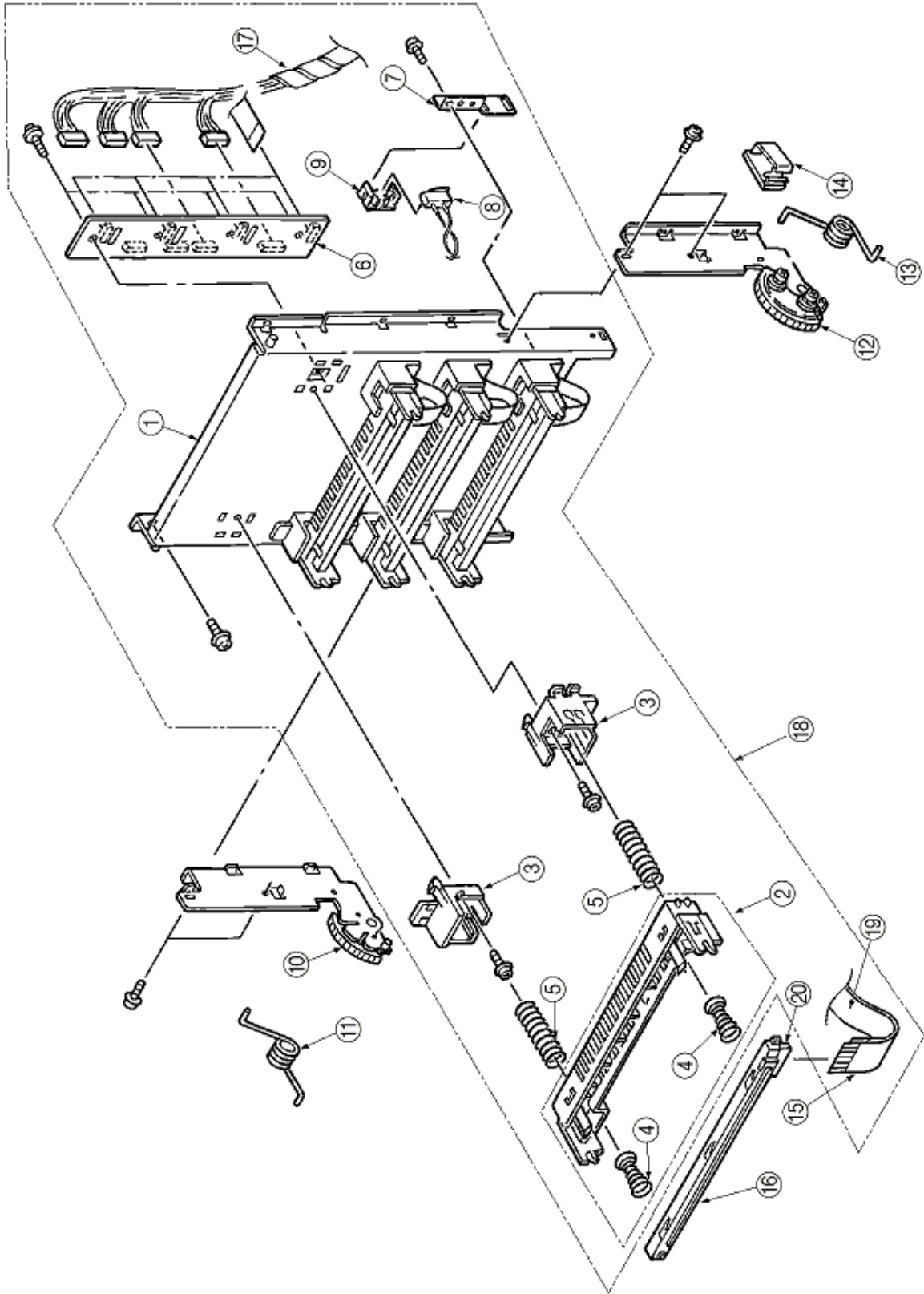
No.	Okidata Part #	Name	Qty	Remarks
1	40310001	Gear Heat Assy	1	
2	40392301	Motor Assy Belt	1	
3	40309101	Main Motor (A) Assy	1	
4	40309201	Main Motor (B) Assy	1	
5	40208101	Gear Oneway (Z30)	4	
6	40664401	Lever Up/Dn2 (YMC)	3	
7	40175001	Bracket Hopping Motor	1	
8	40143401	Gear Idle (92)	1	
9	40143501	Gear Feed (118/17)	1	
10	40164401	Gear Oneway (Z48/74)	1	
11	40124101	Motor Pulse (ID)	3	
12	40634106	Board - PX4	1	
13	40437201	Board - PXF	1	
14	40233901	Cover CU	1	
15	40950902	Board - PCE	1	
16	40376901	Plate Sealed	1	
17	40197101	Motor Fan	1	
18	54122925	Screw (SW+2W)	2	
19	40377001	IF Plate	1	
20	40171002	AMP8P-AMP4PX2	1	
21	40456101	JST12 AMP15 AMP10 AMP9 connection cord	1	
22	40173001	AMP12P-AMP3PX2	1	
23	40171001	AMP8P-AMP4PX2	1	
24	40447101	AMP12P-AMP3PX4	1	
25	40173301	AMP14-AMP3PX4	1	
26	40171801	AMP7P-AMP7P	1	
27	40172401	AMP6P-AMP4P	1	
28	56636203	HCUJ (1.25)-16F-300	1	
29	40172801	AMP12P-AMP4, 3X2	1	
30	40447301	JST6P-AMP3PX2	1	
31	40177701	AMP7P-AMP7P	1	
32	40447001	JST8P-JST8P	1	
33	40172701	AMP8P-AMP2PX4	1	
34	40173308	PS-SIMM	1	
35				
36				
37	40450001	Bell Motor Mech Assy	1	
38				
39	40135301	Photo Interrupter	1	
40	40448901	Gear Heat Mech Assy	1	
41	40664501	Lever Up/Dn2 (K)	1	
42	40583901	Plate Earth (LKR)	4	
43	40704901	Plate Shield (CU)	1	
44	40447201	CONN Cord Wire	1	Designated in Fig A-3
45		EPROM	1	
46				
47		EPROM	1	
48		PROM Control	1	
49		PROM Control	1	
50		PROM Control	1	
51		PROM Control	1	



Figure 8-6: Frame Upper Assy



< same diagram -- side view >



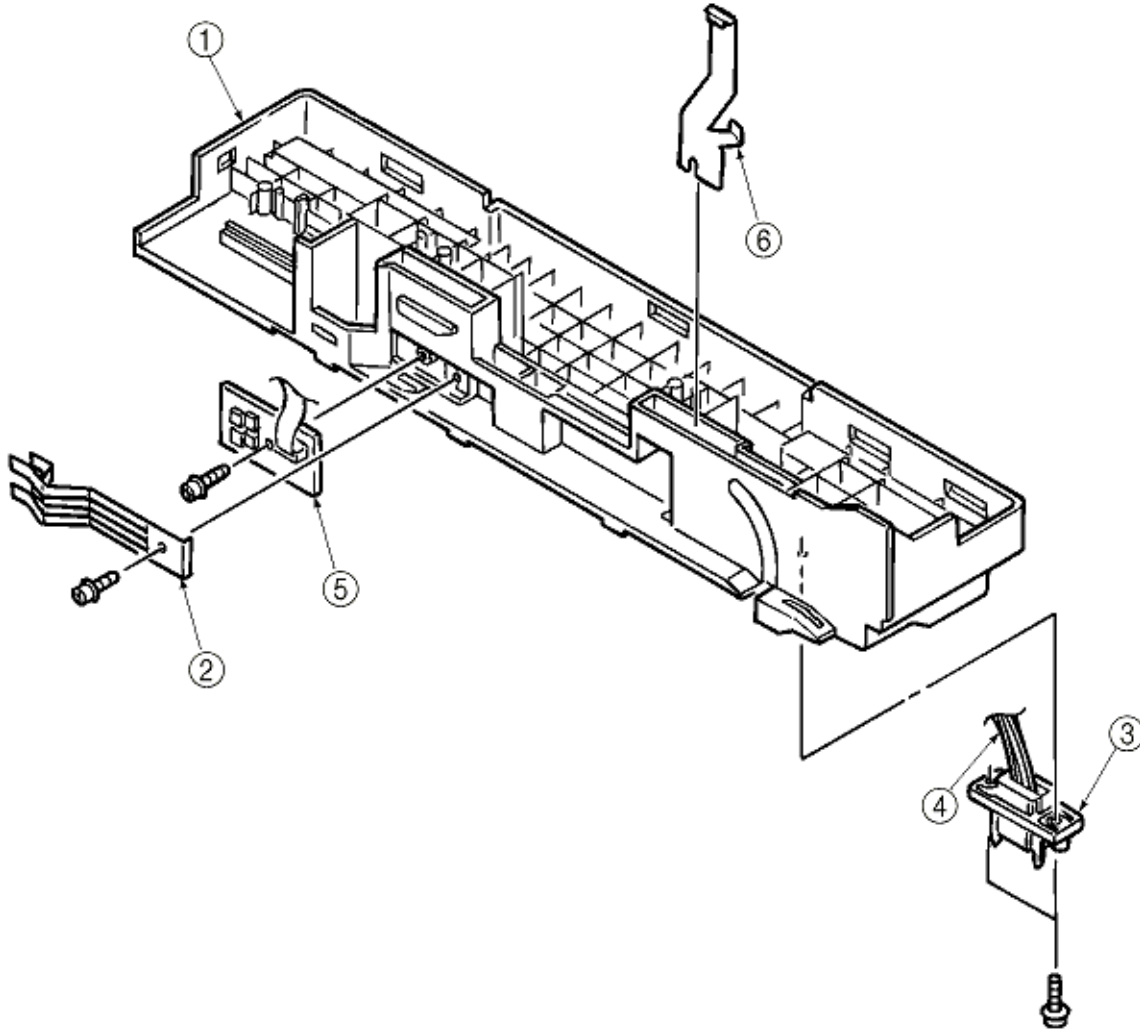
No.	Okidata Part #	Name	Qty	Remarks
1	40187901	Frame Upper	1	
2	40449101	Holder LED Assy	4	
3	40187801	Guide Holder	8	
4	40829701	Spring Head	8	
5	40197705	Spring EP	8	
6	40536001	Boad PD6	1	
7	40394201	Plate Oil Sensor	1	
8	40171702	AMP2P MSW	1	
9	40408601	Holder SW	1	
10	40449301	Plate Support (L) Assy	1	
11	40197401	Torsion Spring (A)	1	
12	40449201	Plate Support (R) Assy	1	
13	40218301	Torsion Spring (B)	1	
14	56636301	Flat Cable Clip	1	
15	56636201	HCLU (1.25) - 14F-140-10S6(B)-MI92896)	4	
16	40547301	LED Head Unit 51 M	4	
17	40456101	JST12 AMP15 AMP10 AMP9 connection cord	1	Designated in Fig A-5
18	40410701	Frame Upper Assy	1	
19	56636206	HCUJ(1.25)-12F-160	4	
20	56730960	(PXW26-1250B) Connector	4	

---

Copyright 1999, Okidata, Division of OKI America, Inc. All rights reserved.



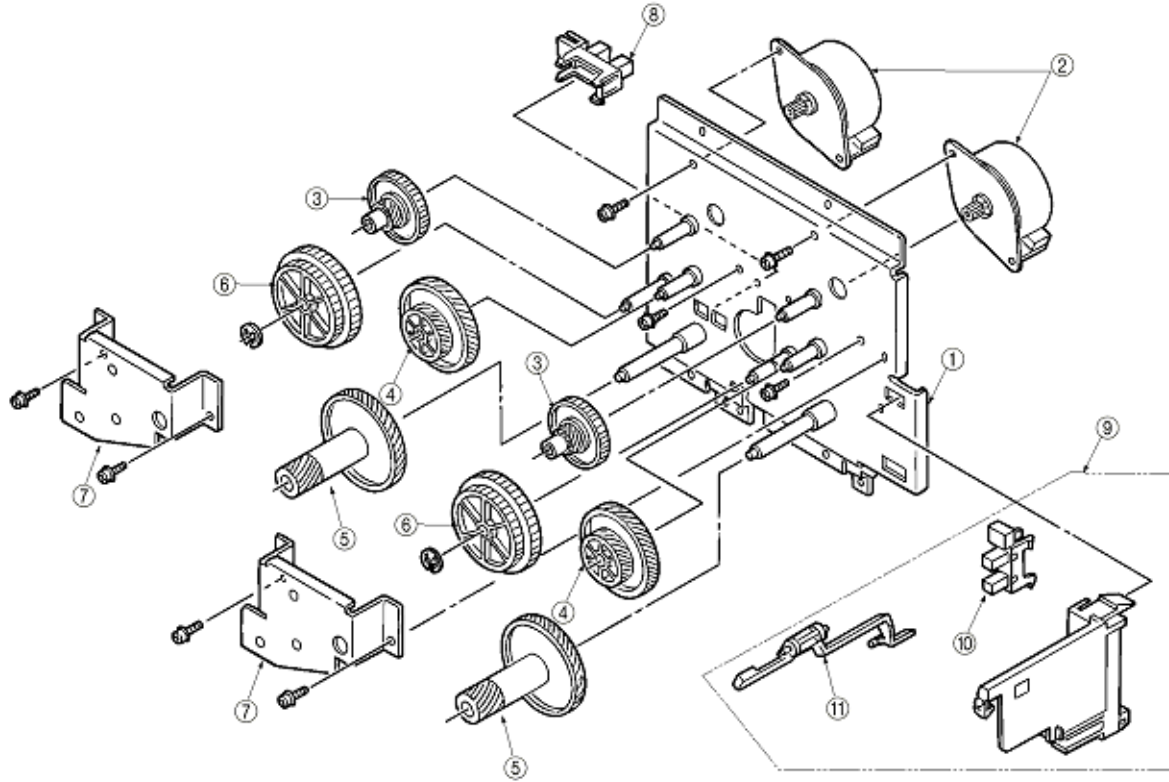
Figure 8-7: Guide Cassette (R) Assy



No.	Okidata Part #	Name	Qty	Remarks
1	40449801	Guide Cassette (R) Sub Assy	1	
2	50928901	Spring Detector	1	
3	56730640	Square shaped connector	1	
4	40177701	Connector Cord	1	
5	40368301	Board - PXC	1	
6	53346601	Plate Earth (link)	1	

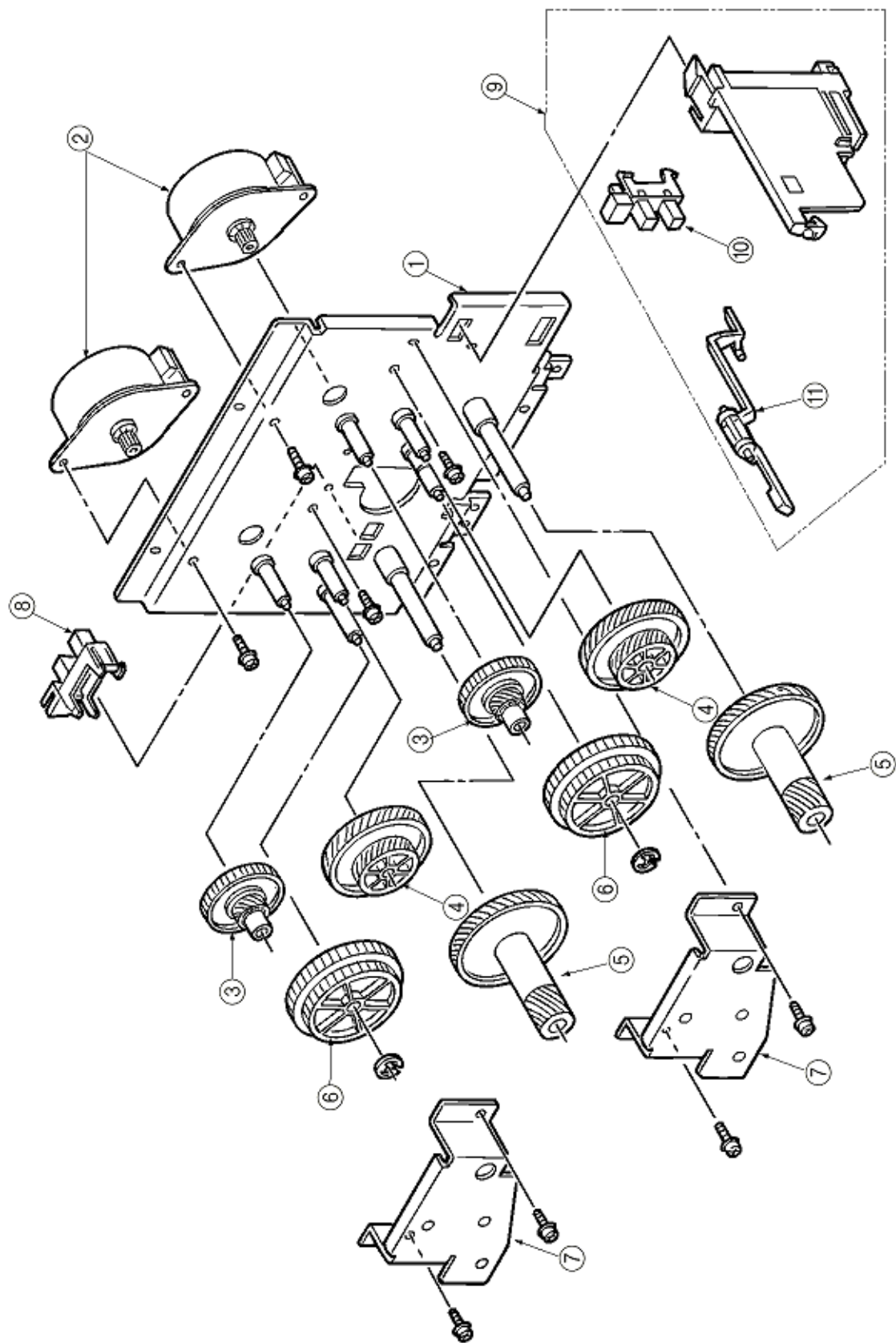


Figure 8-8: Main Motor (A) Assy



< same diagram -- side view >







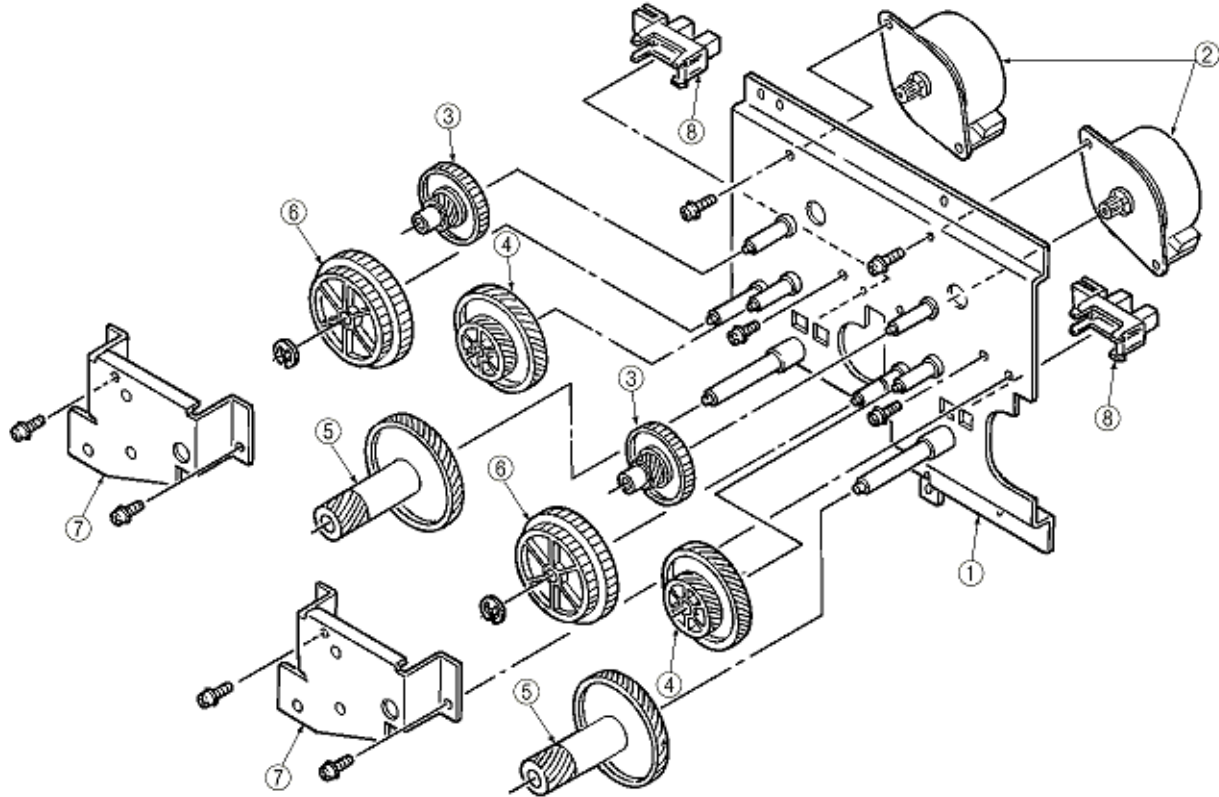
No.	Okidata Part #	Name	Qty	Remarks
1	40165301	Frame Motor (ID1)	1	
2	40124101	Motor Pulse (ID)	2	
3	40129901	Gear (25/75)	2	
4	40130701	Gear Helical (67/43/24)	2	
5	40130601	Gear Helical (67/18)	2	
6	40130201	Gear Z53/44	2	
7	40129501	Bracket Support (ID)	2	
8	40135301	Photo Interrupter	1	
9	40308601	Toner Sesor (Y) Assy	1	
10	40135301	Photo Interrupter	1	
11	40449601	Sensor Assy T (Y)	1	

---

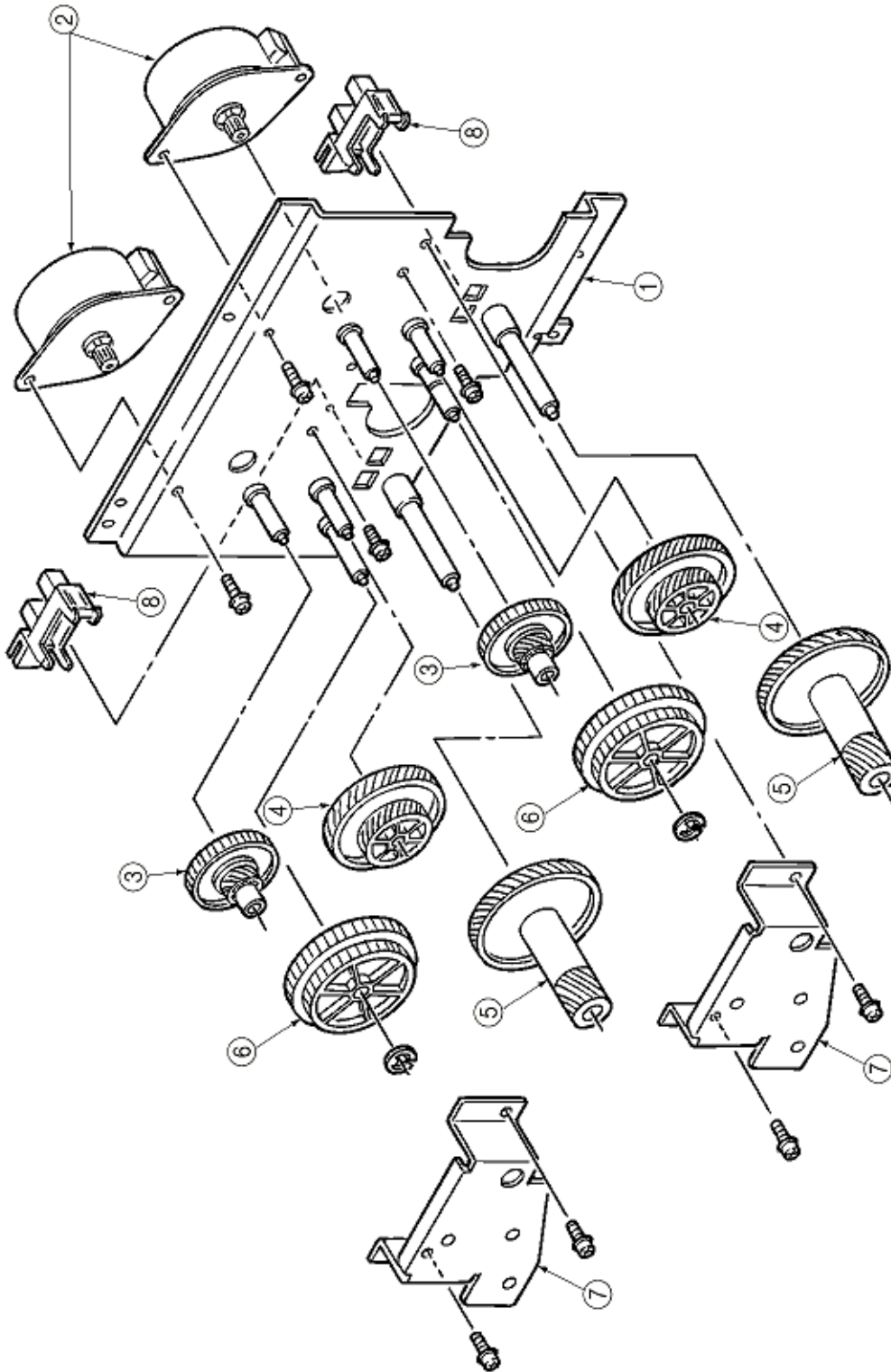
Copyright 1999, Okidata, Division of OKI America, Inc. All rights reserved.



Figure 8-9: Main Motor (B) Assy



< same diagram -- side view >



No.	Okidata Part #	Name	Qty	Remarks
1	40129401	Frame Motor (ID)	1	
2	40124101	Motor Pulse (ID)	2	
3	40129901	Gear (25/75)	2	
4	40130701	Gear Helical (67/43/24)	2	

5	40130601	Gear Helical (67/18)	2	
6	40130201	Gear Z53/44	2	
7	40129501	Bracket Support (ID)	2	
8	40135301	Photo Interrupter	2	

---

Copyright 1999, Okidata, Division of OKI America, Inc. All rights reserved.



---

## Centronics Parallel Interface

### 1) Connector

- Printer side : 36-pin receptacle  
(single port) Type 57RE-40360-830B-D29A (made by Daiichi Denshi), or equivalent
- Cable side : 36-pin plug  
Type 57-30360 (made by Daiichi Denshi) or equivalent  
Plug-552274-1 (AMP), 552073-1 (AMP) or equivalent

### 2) Cable

- Cable length : 6 ft (1.8 m) max.

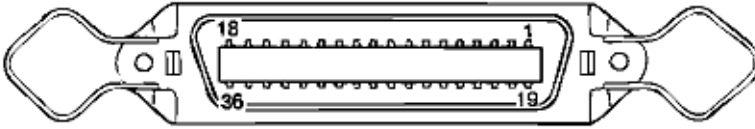
(A Shielded cable composed of twisted pair wires is recommended for noise prevention.)

**Note:** Cable is not supplied with the printer.

### 3) Table of Parallel I/F Signals

Pin No.	Signal name	Signal direction	Functions
1	DATA STROBE	→ PR	Parallel data sampling strobe
2	DATA BIT - 1		
3	DATA BIT - 2		
4	DATA BIT - 3		
5	DATA BIT - 4	→ PR	Parallel input data
6	DATA BIT - 5		
7	DATA BIT - 6		
8	DATA BIT - 7		
9	DATA BIT - 8		
10	ACKNOWLEDGE	← PR	Completion of data input or end of functioning
11	BUSY	← PR	During print processing or during alarm
12	PAPER END	← PR	End of paper
13	SELECT	← PR	Select state (ON-LINE)
14	Auto Feed	→ PR	Request to change Mode
15	-		(Not used)
16	0V		Signal ground
17	CHASSIS GROUND		Chassis ground
18	+5V	← PR	50 mA max.
19			
∴	0V Signal ground		Signal ground
30			
31	INPUT PRIME	→ PR	Initializing signal
32	FAULT	← PR	End of paper or during alarm
33	0V		Signal ground
34	-		(Not used)
35	-		High level (3.3 kΩ)
36	Select In	→ PR	Request to change Mode

- Connector pin arrangement



#### 4) Signal Level

- LOW : 0 V to +0.8 V
- HIGH : +2.4 V to 5.0 V

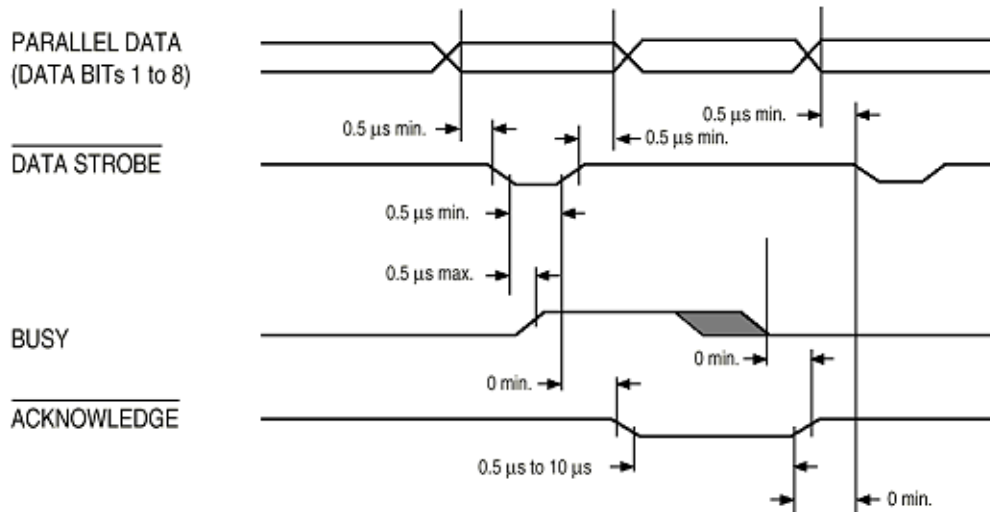
#### 5) Specifications

Item	Description
Mode	Compatibility mode, Nibble mode, ECP mode
Data bit length	8 bits Compatibility mode, 4 bits: Nibble mode, 9 bits: ECP mode
Receive buffer	100K, 512KB, 1M Bytes, AUTO
Control	Handshaking control is performed in each mode. Data received from the host is stored in the receive buffer. Busy control is performed. Signal lead control is performed.

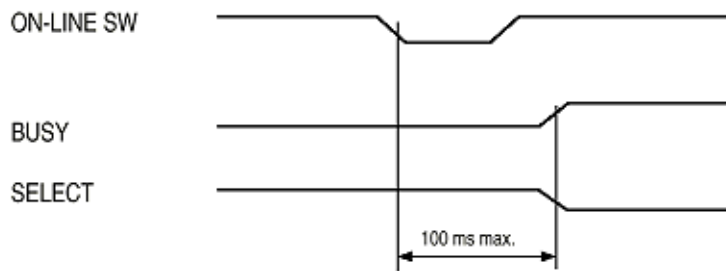
#### 6) Timing Charts

- Compatible mode

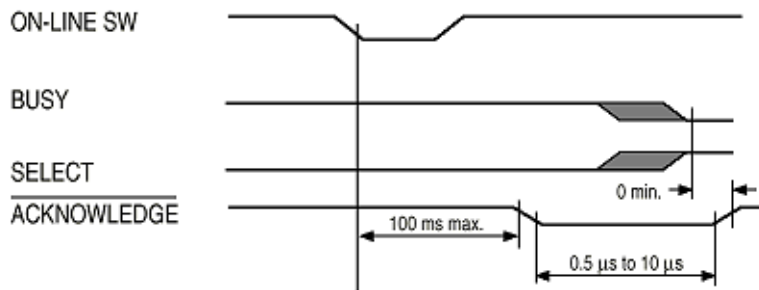
##### a) Data receiving timing



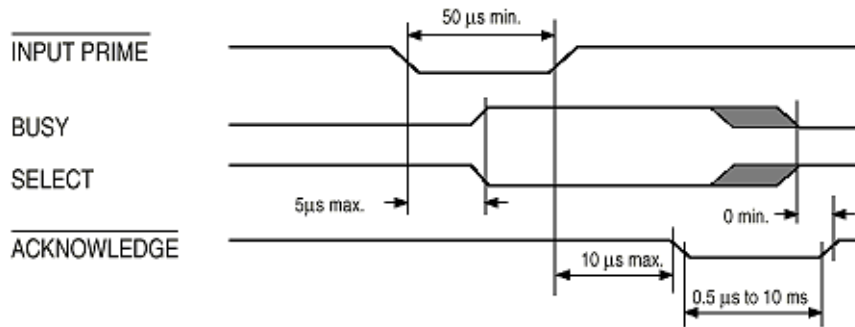
##### b) On-line (off-line switching timing by ON-LINE SW)



c) Off-line (on-line switching by ON-LINE SW)



d) nInit timing (when set to the effective INPUT PRIME signal)



- Nibble mode  
Conforms to IEEE 1284 spec.
- ECP mode  
Conforms to IEEE 1284 spec.